

ATS

ATS



Цилиндрические мотор-редукторы с параллельными валами

Руководство по эксплуатации



Архангельск (8182)63-90-72
Астана (7172)727-132
Белгород (4722)40-23-64
Брянск (4832)59-03-52
Владивосток (423)249-28-31
Волгоград (844)278-03-48
Вологда (8172)26-41-59
Воронеж (473)204-51-73
Екатеринбург (343)384-55-89
Иваново (4932)77-34-06
Ижевск (3412)26-03-58
Казань (843)206-01-48

Калининград (4012)72-03-81
Калуга (4842)92-23-67
Кемерово (3842)65-04-62
Киров (8332)68-02-04
Краснодар (861)203-40-90
Красноярск (391)204-63-61
Курск (4712)77-13-04
Липецк (4742)52-20-81
Магнитогорск (3519)55-03-13
Москва (495)268-04-70
Мурманск (8152)59-64-93
Набережные Челны (8552)20-53-41

Нижний Новгород (831)429-08-12
Новокузнецк (3843)20-46-81
Новосибирск (383)227-86-73
Орел (4862)44-53-42
Оренбург (3532)37-68-04
Пенза (8412)22-31-16
Пермь (342)205-81-47
Ростов-на-Дону (863)308-18-15
Рязань (4912)46-61-64
Самара (846)206-03-16
Санкт-Петербург (812)309-46-40
Саратов (845)249-38-78

Смоленск (4812)29-41-54
Сочи (862)225-72-31
Ставрополь (8652)20-65-13
Тверь (4822)63-31-35
Томск (3822)98-41-53
Тула (4872)74-02-29
Тюмень (3452)66-21-18
Ульяновск (8422)24-23-59
Уфа (347)229-48-12
Челябинск (351)202-03-61
Череповец (8202)49-02-64
Ярославль (4852)69-52-93

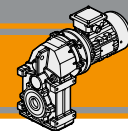

Indice	Index	Pag. Page
Caratteristiche tecniche	<i>Technical features</i>	F2
Designazione	<i>Classification</i>	F3
Sensi di rotazione	<i>Direction of rotation</i>	F4
Simbologia	<i>Symbols</i>	F4
Lubrificazione	<i>Lubrication</i>	F4
Carichi radiali	<i>Radial loads</i>	F5
Dati tecnici	<i>Technical data</i>	F6
Dimensioni	<i>Dimensions</i>	F12
Accessori	<i>Accessories</i>	F16

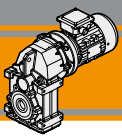

Caratteristiche tecniche

Technical features

I motoriduttori pendolari della serie ATS sono caratterizzati da un elevato grado di modularità: partendo da un corpo di base è possibile configurarlo secondo le esigenze con diversi kit in entrata ed in uscita.

The high degree of modularity is a design feature of ATS helical parallel range. It is possible to set up the version required by using input and output kits.

Caratteristiche comuni a tutta la serie:

The main features of ATS range are:

- Carcassa e flangia PAM in pressofusione di alluminio
- Lubrificazione permanente con olio sintetico.
- Flange di uscita in ghisa.

- *Die-cast aluminum housings and input flanges*
- *Permanent synthetic oil long-life lubrication.*
- *Cast iron output flanges.*

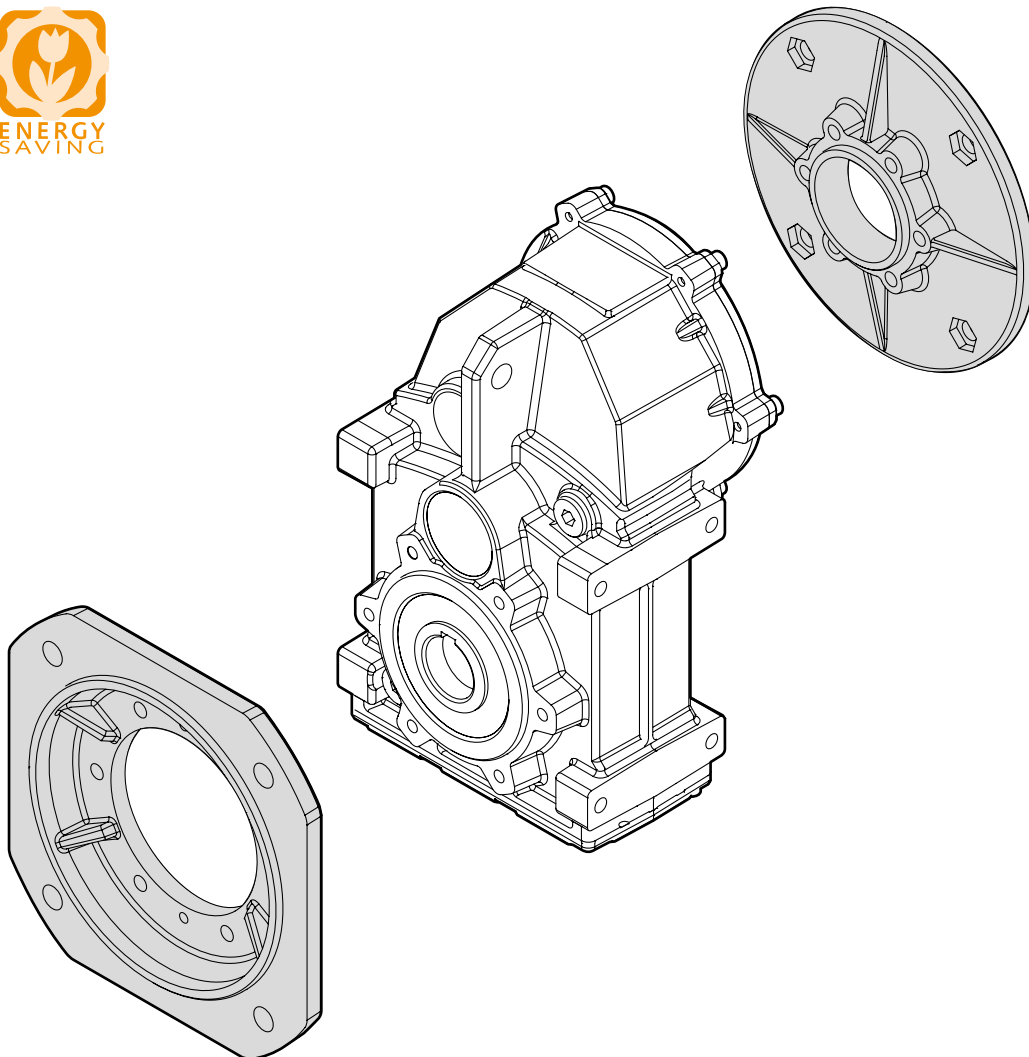

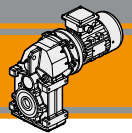

Designazione

Classification

Versione Riduttore
Gearbox Version

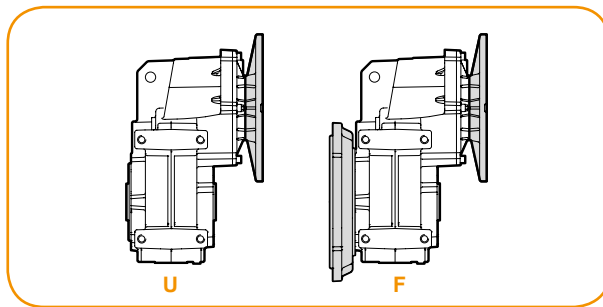

Albero di uscita
Output shaft

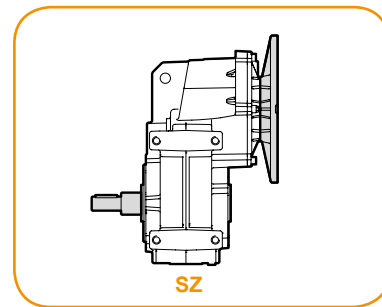

RIDUTTORE / GEARBOX

ATS	90	2	U	29.65	D35	90	B5	SZ
Tipo Type	Grandezza Size	Stadi Stages	Versione Version	Rapporto Ratio	Albero cavo uscita Hollow output shaft	IEC 	Forma costruttiva Version	Albero uscita maschio Solid output shaft
 ATS	90 91	2 3	U... F...	vedi tabelle see tables	vedi tabelle see tables	63.. — 112..	B5 B14	SZ

ATS

Versione Riduttore
Gearbox Version

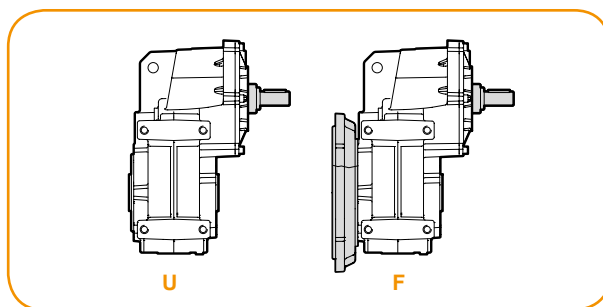

Albero di uscita
Output shaft

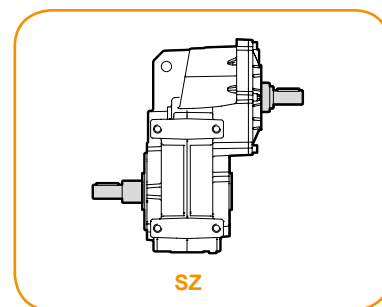

RIDUTTORE / GEARBOX

ATSIS	90	2	U	29.65	D35	SZ
Tipo Type	Grandezza Size	Stadi Stages	Versione Version	Rapporto Ratio	Albero cavo uscita Hollow output shaft	Albero uscita maschio Solid output shaft
 ATSIS	90 91	2 3	U... F...	vedi tabelle see tables	vedi tabelle see tables	SZ

MOTORE / MOTOR

0.75kW	4p	3ph	230/400V	50Hz	T1
Potenza Power	Poli Poles	Fasi Phases	Tensione Voltage	Frequenza Frequency	Pos. morsetteria Terminal box pos.
vedi tabelle see tables	2p 4p 6p 8p	1ph 3ph	230V 230/400V	50Hz 60Hz	T1 (Std)

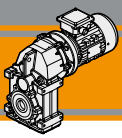

ATS...2
ATSIS..2

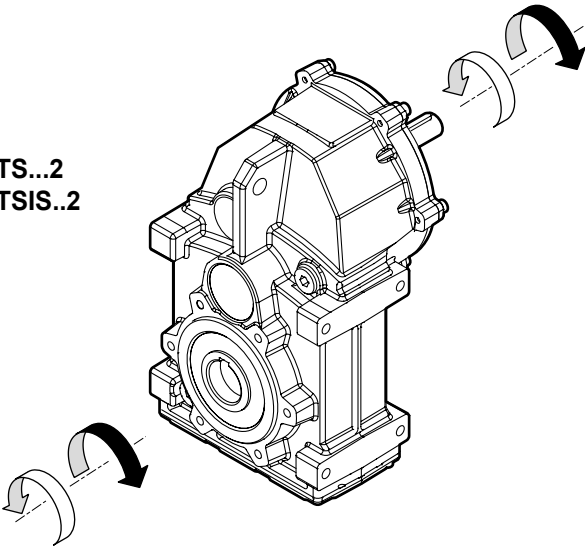

ATS...3
ATSIS..3

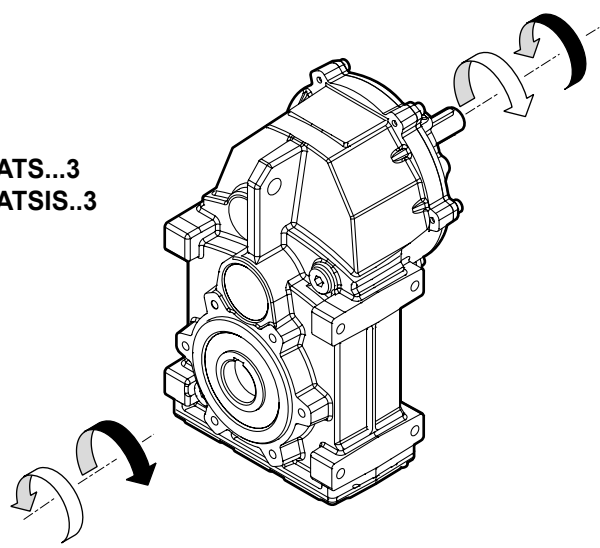

Simbologia

Symbols

n_1	[min ⁻¹]	Velocità in ingresso / <i>Input speed</i>
n_2	[min ⁻¹]	Velocità in uscita / <i>Output speed</i>
i		Rapporto di riduzione / <i>Ratio</i>
P_1	[kW]	Potenza in entrata / <i>Input power</i>
M_2	[Nm]	Coppia nominale in uscita in funzione di P_1 / <i>Output torque referred to P_1</i>
P_{n1}	[kW]	Potenza nominale in entrata / <i>Nominal input power</i>
M_{n2}	[Nm]	Coppia nominale in uscita in funzione di P_{n1} / <i>Nominal output torque referred to P_{n1}</i>
sf		Fattore di servizio / <i>Service factor</i>
R_2	[N]	Carico radiale ammissibile in uscita / <i>Permitted output radial load</i>
A_2	[N]	Carico assiale ammissibile in uscita / <i>Permitted output axial load</i>

Lubrificazione

Lubrication

Tutti i motoriduttori sono forniti completi di lubrificante sintetico viscosità 320, pertanto possono essere installati in qualunque posizione di montaggio e non necessitano di manutenzione.

Permanent synthetic oil long-life lubrication (viscosity grade 320) makes it possible to use the gearmotors in all mounting positions; for this reason they can be installed in any assembly position and do not require maintenance.

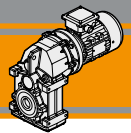

Carichi radiali

Radial loads

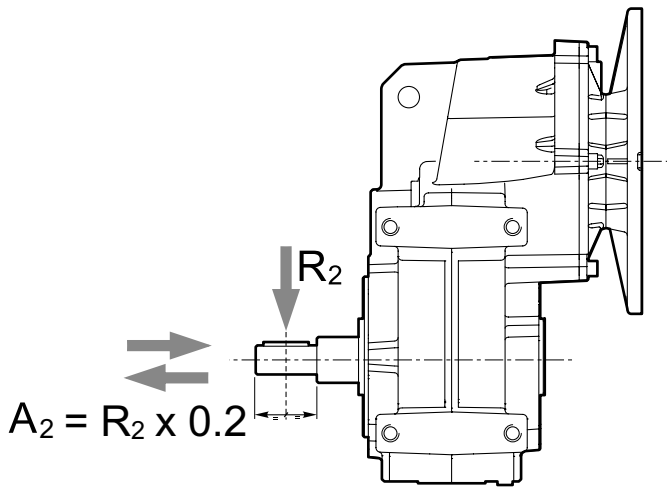

n_2 [min ⁻¹]	R_2 [N]	
	ATS 902 ATS 903	ATS 912 ATS 913
240	2400	3600
180	2400	4200
150	2400	4200
120	2500	4600
100	2800	4800
85	3090	5100
70	3150	5250
55	3630	6000
40	4440	6900
30	5100	7800
20	6000	9500
15	6000	10000
10	6000	10000
5	6000	10000

ATS

Quando il carico radiale risultante non è applicato sulla mezza-
ria dell'albero occorre calcolare quello effettivo con la seguente
formula:

When the resulting radial load is not applied on the centre line
of the shaft it is necessary to calculate the effective load with the
following formula:

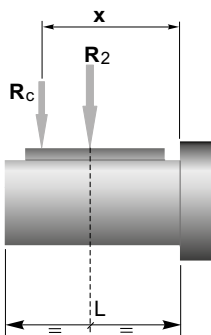

	ATS 902 ATS 903	ATS 912 ATS 913
a	152	174.5
b	97	114.5
R_{2MAX}	6000	10000

$$R_c = \frac{R_2 \cdot a}{(b+x)} \leq R_{2MAX}$$

$$R \leq R_c$$

a, b = valori riportati nella tabella
a, b = values given in the table

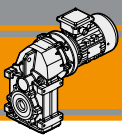

Dati tecnici

n_1 1400 min⁻¹

Technical data

	n_2 [min ⁻¹]	Mn_2 [Nm]	Pn_1 [kW]	i	IEC Motori applicabili IEC Motor adapters					
					71 B5	80 B5/B14	90 B5/B14	100 B5/B14	112 B5/B14	
ATSIS 902										
	239	200	5.2	5.87	B					
	178	250	4.9	7.87	B					
	148	300	4.8	9.47	B					
	121	350	4.6	11.53	B					
	106	350	4.0	13.26	B					
	89.3	350	3.4	15.68	B					
	84.0	350	3.2	16.68	B					*
	73.3	400	3.2	19.09	B					*
	63.7	400	2.8	21.96	B					*
	52.8	400	2.3	26.50	B					*
	50.7	400	2.2	27.61	B					*
	47.2	400	2.1	29.65	B					*
	41.8	400	1.8	33.49	B			*		*
	39.0	400	1.7	35.87	B			*		*
	36.6	400	1.6	38.29	B			*		*
	31.9	400	1.4	43.88	B			*		*
	28.5	400	1.3	49.09	B			*		*
	26.6	400	1.2	52.71	B			*		*
	25.2	400	1.1	55.45	B			*		*
	22.1	400	0.98	63.41	B		*	*		*
	19.0	400	0.85	73.64	B		*	*		*
	16.0	400	0.71	87.27	B		*	*		*

ATSIS 903					63 B5	71 B5/B14	80 B5/B14	90 B5/B14
	14.0	400	0.62	100.33				*
	11.1	400	0.50	125.89				*
	10.6	400	0.47	131.65				*
	10.0	400	0.45	139.88			*	*
	9.3	400	0.41	151.07			*	*
	8.4	400	0.38	166.13			*	*
	8.1	400	0.36	172.40			*	*
	6.7	400	0.30	208.45			*	*
	6.3	400	0.28	223.41			*	*
	5.6	400	0.25	250.14			*	*
	4.3	400	0.19	323.65		*	*	*
	4.1	400	0.18	345.59		*	*	*
	3.7	400	0.17	376.15		*	*	*
	3.3	400	0.15	424.21		*	*	*

N.B.
Le aree evidenziate indicano l'applicabilità della corrispondente grandezza motore.

B = Boccola di riduzione in acciaio.



* = Il fattore di servizio (**sf**) deve essere scelto in funzione dell'applicazione: si prega di contattare il nostro Servizio Tecnico.

Prima di eseguire la scelta del motoriduttore riferirsi alle prestazioni elencate nelle tabelle dalla pag. F8 alla pag. F11

N.B.

Highlighted areas indicate motor inputs available on each size of unit.
B = Metal shaft sleeve.



* = The service factor (**sf**) has to be selected depending on application: please contact our Technical Department.

Before selecting any gearbox, please read the performance values shown in the tables on page F8 to F11.

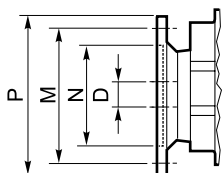

Dimensioni IEC / IEC Dimensions									
	63 B5	71 B5	71 B14	80 B5	80 B14	90 B5	90 B14	100/112 B5	100/112 B14
N	95	110	70	130	80	130	95	180	110
M	115	130	85	165	100	165	115	215	130
P	140	160	105	200	120	200	140	250	160
D	11	14		19		24		28	

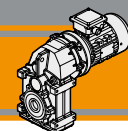

Dati tecnici

n_1 1400 min⁻¹

Technical data

	n_2 [min ⁻¹]	Mn_2 [Nm]	Pn_1 [kW]	i	IEC Motori applicabili IEC Motor adapters					
					71 B5	80 B5/B14	90 B5/B14	100 B5/B14	112 B5/B14	
ATSIS 912										
	245.0	350	9.4	5.71	B					
	183	350	7.0	7.66	B					
	158	400	6.9	8.85	B					
	152	400	6.6	9.22	B					
	125	400	5.4	11.23	B					
	118	400	5.1	11.87	B					
	108	500	5.9	12.92	B					
	98.0	500	5.3	14.29	B					
	86.2	500	4.7	16.24	B					
	80.5	500	4.4	17.39	B					
	70.0	600	4.6	20.01	B					
	66.3	600	4.3	21.10	B					
	55.6	600	3.6	25.16	B					
	54.2	600	3.5	25.81	B					*
	48.5	600	3.2	28.88	B					*
	42.8	600	2.9	32.69	B					*
	37.5	600	2.5	37.30	B					*
	35.0	600	2.3	39.98	B					*
	31.3	600	2.1	44.73	B					*
	27.7	600	1.9	50.53	B			*		*
	24.2	600	1.6	57.77	B			*		*
	20.9	600	1.4	67.09	B			*		*
	17.6	600	1.2	79.52	B			*		*

ATSIS913					63 B5	71 B5/B14	80 B5/B14	90 B5/B14
	17.0	600	1.1	82.28				
	14.9	600	1.0	93.96				
	13.8	600	0.92	101.41				*
	11.4	600	0.76	122.61				*
	10.7	600	0.71	131.41				*
	9.5	600	0.64	147.13				*
	8.9	600	0.60	157.08				*
	7.4	600	0.49	189.92				*
	6.9	600	0.46	203.55			*	*
	6.1	600	0.41	227.91			*	*
	4.7	600	0.32	294.88			*	*
	4.4	600	0.30	314.87			*	*
	4.1	600	0.27	342.72			*	*
	3.6	600	0.24	386.51			*	*

N.B.
Le aree evidenziate indicano l'applicabilità della corrispondente grandezza motore.
B = Boccola di riduzione in acciaio.

N.B.
Highlighted areas indicate motor inputs available on each size of unit.
B = Metal shaft sleeve.

 * = Il fattore di servizio (sf) deve essere scelto in funzione dell'applicazione: si prega di contattare il nostro Servizio Tecnico.

 * = The service factor (sf) has to be selected depending on application: please contact our Technical Department.

Prima di eseguire la scelta del motoriduttore riferirsi alle prestazioni elencate nelle tabelle dalla pag. F8 alla pag. F11

Before selecting any gearbox, please read the performance values shown in the tables on page F8 to F11.

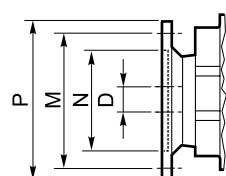



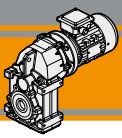

Dimensioni IEC / IEC Dimensions									
	63 B5	71 B5	71 B14	80 B5	80 B14	90 B5	90 B14	100/112 B5	100/112 B14
N	95	110	70	130	80	130	95	180	110
M	115	130	85	165	100	165	115	215	130
P	140	160	105	200	120	200	140	250	160
D	11	14		19		24		28	



ATS Motoriduttori pendolari Helical parallel gearmotors

Dati tecnici



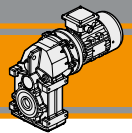

Technical data

P_1 [kW]	n_2 [min ⁻¹]	M_2 [Nm]	sf	i			P_1 [kW]	n_2 [min ⁻¹]	M_2 [Nm]	sf	i		
0.12							0.25						
63A4 (1400 min ⁻¹)	14.0	77	5.2	100.33	ATS903	B5	71A4 (1400 min ⁻¹)	238	10	20.8	5.87	ATS902	B5
	11.1	97	4.1	125.89		B5		178	13	19.4	7.87		B5
	10.6	101	3.9	131.65		B5		148	16	19.3	9.47		B5
	10.0	108	3.7	139.88		B5		121	19	18.5	11.53		B5
	9.3	116	3.4	151.07		B5		106	22	16.1	13.26		B5
	8.4	128	3.1	166.13		B5		89.3	26	13.6	15.68		B5
	8.1	133	3.0	172.40		B5		84.0	27	12.8	16.68		B5
	6.7	160	2.5	208.45		B5		73.3	31	12.8	19.09		B5
	6.3	172	2.3	223.41		B5		63.7	36	11.1	21.96		B5
	5.6	192	2.1	250.14		B5		52.8	43	9.2	26.50		B5
	4.3	249	1.6	323.65	B5	50.7		45	8.8	27.61	B5		
	4.1	266	1.5	345.59	B5	47.2		49	8.2	29.65	B5		
	3.7	289	1.4	376.15	B5	41.8		55	7.3	33.49	B5		
	3.3	326	1.2	424.21	B5	39.0		59	6.8	35.87	B5		
	6.9	157	3.8	203.55	ATS913	B5		36.6	61	6.5	38.29	B5	
	6.1	175	3.4	227.91		B5		31.9	70	5.7	43.88	B5	
	4.7	227	2.6	294.88		B5		28.5	79	5.1	49.09	B5	
	4.4	242	2.5	314.87		B5		26.6	84	4.7	52.71	B5	
	4.1	264	2.3	342.72		B5		25.2	89	4.5	55.45	B5	
	3.6	297	2.0	386.51		B5		22.1	102	3.9	63.41	B5	
				B5		19.0	118	3.4	73.64	B5			
				B5		16.0	140	2.9	87.27	B5			
0.18							14.0	161	2.5	100.33	ATS903	B5/B14	
63B4 (1400 min ⁻¹)	14.0	116	3.5	100.33	ATS903	B5	11.1	202	2.0	125.89		B5/B14	
	11.1	145	2.8	125.89		B5	10.6	211	1.9	131.65		B5/B14	
	10.6	152	2.6	131.65		B5	10.0	224	1.8	139.88		B5/B14	
	10.0	161	2.5	139.88		B5	9.3	242	1.7	151.07		B5/B14	
	9.3	174	2.3	151.07		B5	8.4	266	1.5	166.13		B5/B14	
	8.4	192	2.1	166.13		B5	8.1	276	1.4	172.40		B5/B14	
	8.1	199	2.0	172.40		B5	6.7	334	1.2	208.45		B5/B14	
	6.7	241	1.7	208.45		B5	6.3	358	1.1	223.41		B5/B14	
	6.3	258	1.6	223.41		B5	5.6	401	1.0	250.14		B5/B14	
	5.6	289	1.4	250.14		B5	13.8	163	3.7	101.41	ATS913	B5/B14	
	4.3	374	1.1	323.65	B5	11.4	197	3.1	122.61	B5/B14			
	4.1	399	1.0	345.59	B5	10.7	211	2.8	131.41	B5/B14			
	3.7	434	0.9	376.15	B5	9.5	236	2.5	147.13	B5/B14			
	3.3	490	0.8	424.21	B5	8.9	252	2.4	157.08	B5/B14			
	9.5	170	3.5	147.13	ATS913	B5	7.4	304	2.0	189.92		B5/B14	
	8.9	181	3.3	157.08		B5	6.9	326	1.8	203.55		B5/B14	
	7.4	219	2.7	189.92		B5	6.1	365	1.6	227.91		B5/B14	
	6.9	235	2.6	203.55		B5	4.7	473	1.3	294.88		B5/B14	
	6.1	263	2.3	227.91		B5	4.4	505	1.2	314.87		B5/B14	
	4.7	340	1.8	294.88		B5	4.1	549	1.1	342.72	B5/B14		
4.4	363	1.7	314.87	B5		3.6	620	1.0	386.51	B5/B14			
4.1	396	1.5	342.72	B5									
3.6	446	1.3	386.51	B5									



Dati tecnici

Technical data

P ₁ [kW]	n ₂ [min ⁻¹]	M ₂ [Nm]	sf	i			P ₁ [kW]	n ₂ [min ⁻¹]	M ₂ [Nm]	sf	i				
0.37							0.55								
71B4 (1400 min ⁻¹)	239	14	14.1	5.87	ATS902	B5	80A4 (1400 min ⁻¹)	239	21	9.5	5.87	ATS902	B5/B14		
	178	19	13.1	7.87				178	28	8.8	7.87				B5/B14
	148	23	13.1	9.47				148	34	8.8	9.47				B5/B14
	121	28	12.5	11.53				121	42	8.4	11.53				B5/B14
	106	32	10.9	13.26				106	48	7.3	13.26				B5/B14
	89.3	38	9.2	15.68				89.3	56	6.2	15.68				B5/B14
	84.0	40	8.7	16.68				84.0	60	5.8	16.68				B5/B14
	73.3	46	8.6	19.09				73.3	69	5.8	19.09				B5/B14
	63.7	53	7.5	21.96				63.7	79	5.1	21.96				B5/B14
	52.8	64	6.2	26.50				52.8	95	4.2	26.50				B5/B14
	50.7	67	6.0	27.61				50.7	99	4.0	27.61				B5/B14
	47.2	72	5.6	29.65				47.2	107	3.7	29.65				B5/B14
	41.8	81	4.9	33.49				41.8	121	3.3	33.49				B5/B14
	39.0	87	4.6	35.87				39.0	129	3.1	35.87				B5/B14
	36.6	91	4.4	38.29				36.6	135	3.0	38.29				B5/B14
	31.9	104	3.8	43.88				31.9	155	2.6	43.88				B5/B14
	28.5	116	3.4	49.09				28.5	173	2.3	49.09				B5/B14
	26.6	125	3.2	52.71				26.6	186	2.2	52.71				B5/B14
	25.2	132	3.0	55.45				25.2	196	2.0	55.45				B5/B14
	22.1	150	2.7	63.41				22.1	224	1.8	63.41				B5/B14
	19.0	175	2.3	73.64				19.0	260	1.5	73.64				B5/B14
	16.0	207	1.9	87.27				16.0	308	1.3	87.27				B5/B14
	14.0	238	1.7	100.33	ATS903	B5/B14	14.0	354	1.1	100.33	ATS903	B5/B14			
	11.1	299	1.3	125.89				11.1	444	0.9			125.89		B5/B14
	10.6	312	1.3	131.65				10.6	464	0.9			131.65		B5/B14
	10.0	332	1.2	139.88											
	9.3	358	1.1	151.07		9.3	358	1.1	151.07		ATS912	B5/B14			
	8.4	394	1.0	166.13		8.4	394	1.0	166.13		B5/B14	B5/B14			
	8.1	409	1.0	172.40		8.1	409	1.0	172.40		B5/B14	B5/B14			
	24.2	137	4.4	57.77	ATS912	B5	17.6	280	2.1	79.52	ATS913	B5/B14			
	20.9	159	3.8	67.09				20.9	237	2.5			67.09		B5/B14
	17.6	189	3.2	79.52				17.6	280	2.1			79.52		B5/B14
	17.0	195	3.1	82.28	ATS913	B5/B14	14.9	331	1.8	93.96	ATS913	B5/B14			
	14.9	223	2.7	93.96				14.9	331	1.8			93.96		B5/B14
	13.8	241	2.5	101.41				13.8	358	1.7			101.41		B5/B14
	11.4	291	2.1	122.61				11.4	432	1.4			122.61		B5/B14
	10.7	312	1.9	131.41				10.7	463	1.3			131.41		B5/B14
	9.5	349	1.7	147.13				9.5	519	1.2			147.13		B5/B14
	8.9	373	1.6	157.08				8.9	554	1.1			157.08		B5/B14
	7.4	451	1.3	189.92				7.4	670	0.9			189.92		B5/B14
	6.9	483	1.2	203.55											B5/B14
	6.1	541	1.1	227.91											B5/B14
	4.7	700	0.9	294.88							B5/B14				



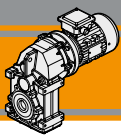

ATS



ATS Motoriduttori pendolari Helical parallel gearmotors

Dati tecnici

Technical data

P_1 [kW]	n_2 [min ⁻¹]	M_2 [Nm]	sf	i			P_1 [kW]	n_2 [min ⁻¹]	M_2 [Nm]	sf	i								
0.75							1.1												
80B4 (1400 min ⁻¹)	239	29	6.9	5.87	ATS902	B5/B14	90S4 (1400 min ⁻¹)	239	42	4.7	5.87	ATS902	B5/B14						
	178	39	6.5	7.87				178	57	4.4	7.87			B5/B14					
	148	47	6.4	9.47				148	68	4.4	9.47								
	121	57	6.2	11.53				121	83	4.2	11.53								
	106	65	5.4	13.26				106	96	3.7	13.26								
	89.3	77	4.5	15.68				89.3	113	3.1	15.68								
	84.0	82	4.3	16.68				84.0	120	2.9	16.68								
	73.3	94	4.3	19.09				73.3	138	2.9	19.09								
	63.7	108	3.7	21.96				63.7	158	2.5	21.96								
	52.8	130	3.1	26.50				52.8	191	2.1	26.50								
	50.7	136	2.9	27.61				50.7	199	2.0	27.61								
	47.2	146	2.7	29.65				47.2	214	1.9	29.65								
	41.8	164	2.4	33.49				41.8	241	1.7	33.49								
	39.0	176	2.3	35.87				39.0	258	1.5	35.87								
	36.6	184	2.2	38.29				36.6	270	1.5	38.29								
	31.9	211	1.9	43.88				31.9	310	1.3	43.88								
	28.5	236	1.7	49.09				28.5	346	1.2	49.09								
	26.6	253	1.6	52.71				26.6	372	1.1	52.71								
	25.2	267	1.5	55.45				25.2	391	1.0	55.45								
	22.1	305	1.3	63.41				B5/B14	66.3	152	3.9				21.10	ATS912	B5/B14		
	19.0	354	1.1	73.64				B5/B14	55.6	181	3.3				25.16			B5/B14	
	16.0	420	1.0	87.27				B5/B14	54.2	186	3.2				25.81				
	42.8	157	3.8	32.69				ATS912	B5/B14	48.5	204				2.9				28.88
	37.5	179	3.3	37.30						42.8	231				2.6				32.69
	35.0	192	3.1	39.98						37.5	263				2.3				37.30
	31.3	215	2.8	44.73						35.0	282				2.1				39.98
	27.7	243	2.5	50.53						31.3	315				1.9				44.73
	24.2	278	2.2	57.77						27.7	356				1.7				50.53
	20.9	323	1.9	67.09						24.2	407				1.5				57.77
	17.6	382	1.6	79.52						20.9	473				1.3	67.09			
	17.6	382	1.6	79.52						17.6	561				1.1	79.52			
	17.0	396	1.5	82.28						17.0	580				1.0	82.28	ATS913	B5/B14	
14.9	452	1.3	93.96	14.9	663	0.9	93.96												
13.8	488	1.2	101.41	B5/B14															
11.4	590	1.0	122.61	B5/B14															
10.7	632	0.9	131.41	B5/B14															

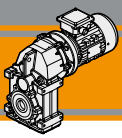

ATS 902

ATS 902 U..

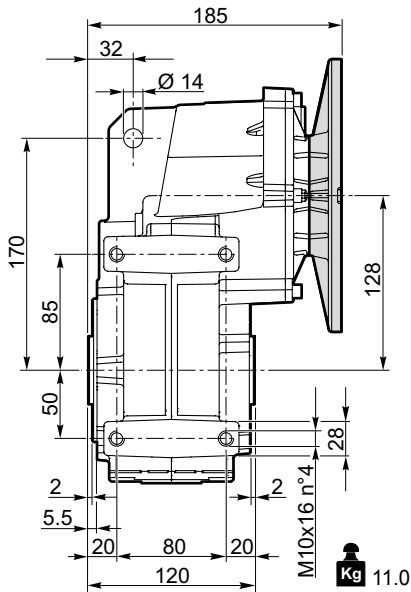

ATSIS 902 U..

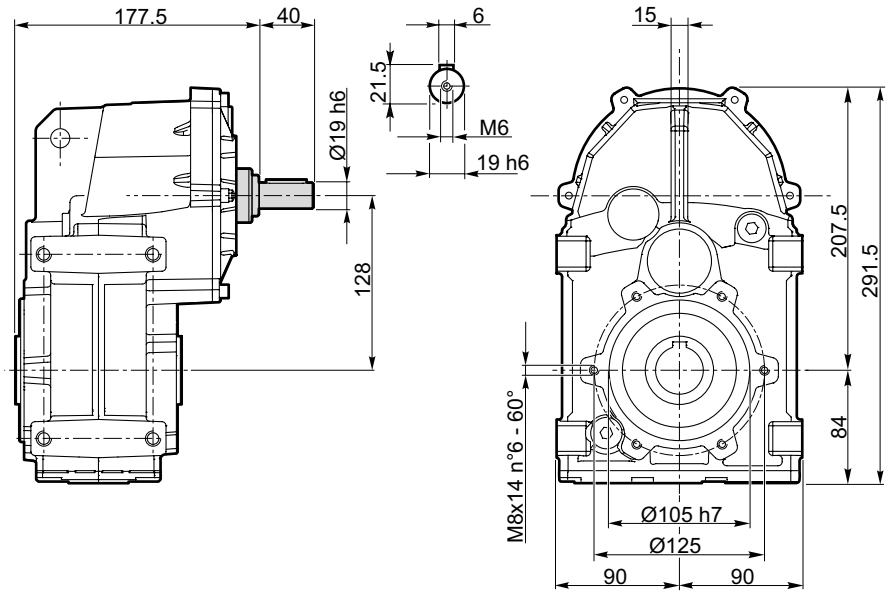

ATS 902 F..

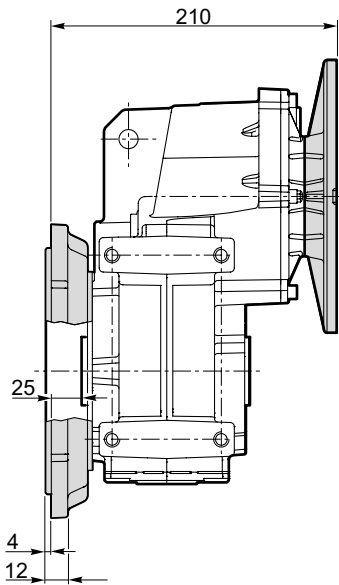

ATSIS 902 F..

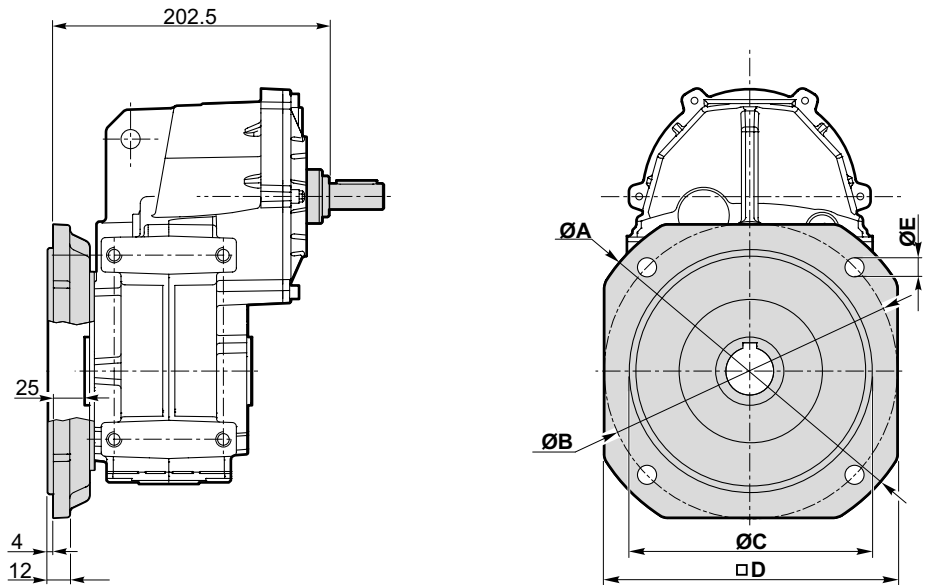

Versione F / F Version

ATS ATSIS	ØA	ØB	ØC f7	□D	ØE	Flangia / Flange	
						Tipo / Type	Peso / Weight [kg]
902	200	165	130	165	11	F200	2
	250	215	180	215	14	F250	3.2

ATS 902.. D35 - ATSIS 902.. D35

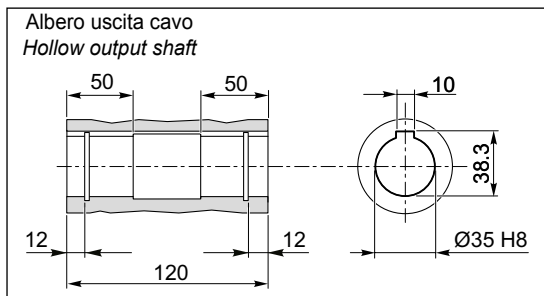

Flangia entrata
Input flange

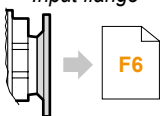

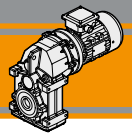

Dimensioni

Dimensions

ATS 903

ATS 903 U..

ATSIS 903 U..

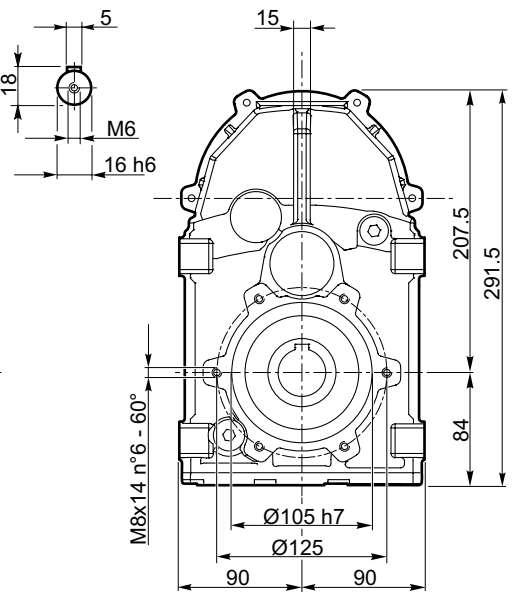
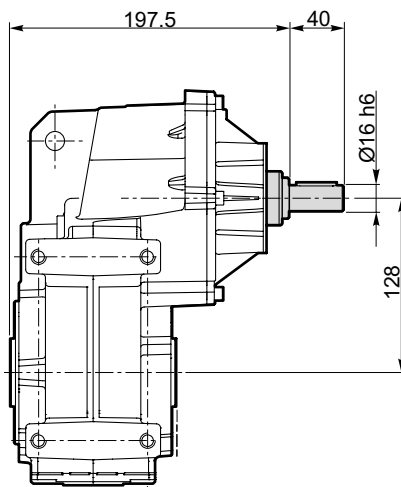
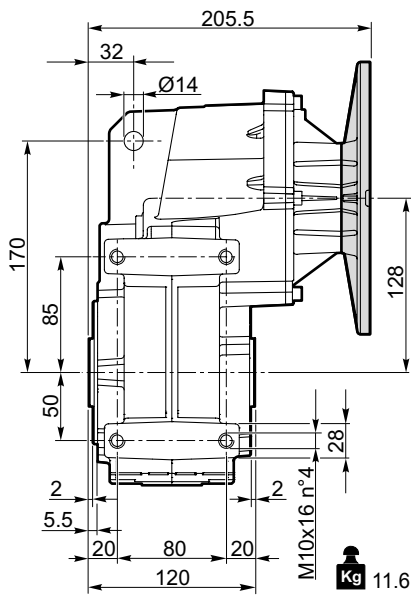

ATS 903 F..

ATSIS 903 F..

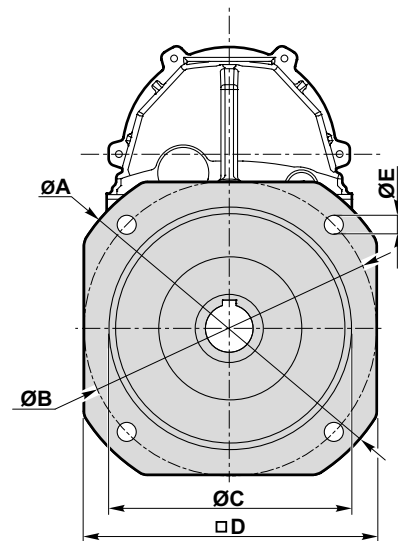
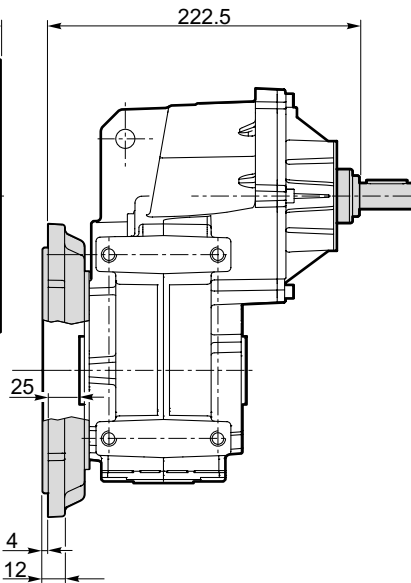
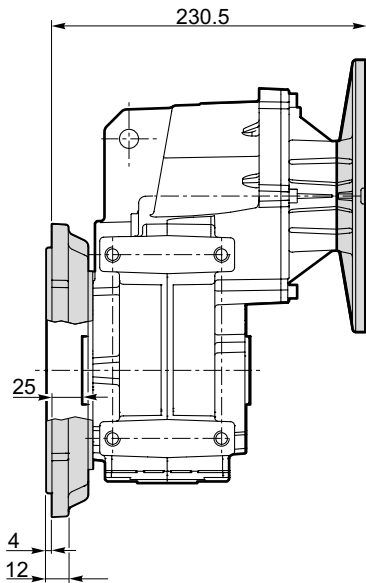

Versione F / F Version							
ATS ATSIS	ØA	ØB	ØC f7	□D	ØE	Flangia / Flange	
						Tipo / Type	Peso / Weight [kg]
903	200	165	130	165	11	F200	2
	250	215	180	215	14	F250	3.2

ATS 903.. D35 - ATSIS 903.. D35

Flangia entrata
Input flange

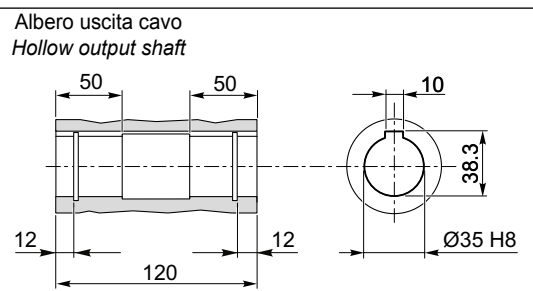
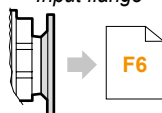

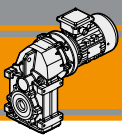

ATS 912

ATS 912 U..

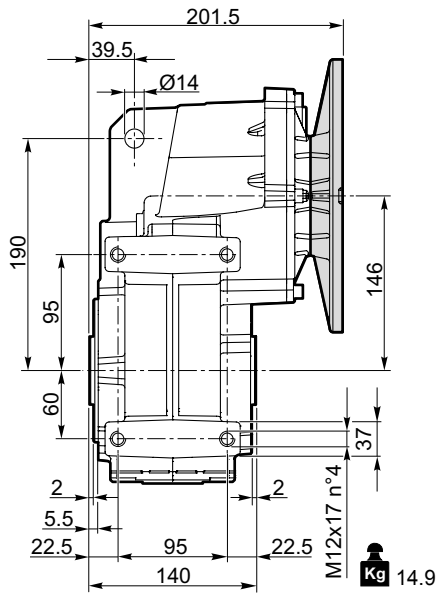

ATSIS 912 U..

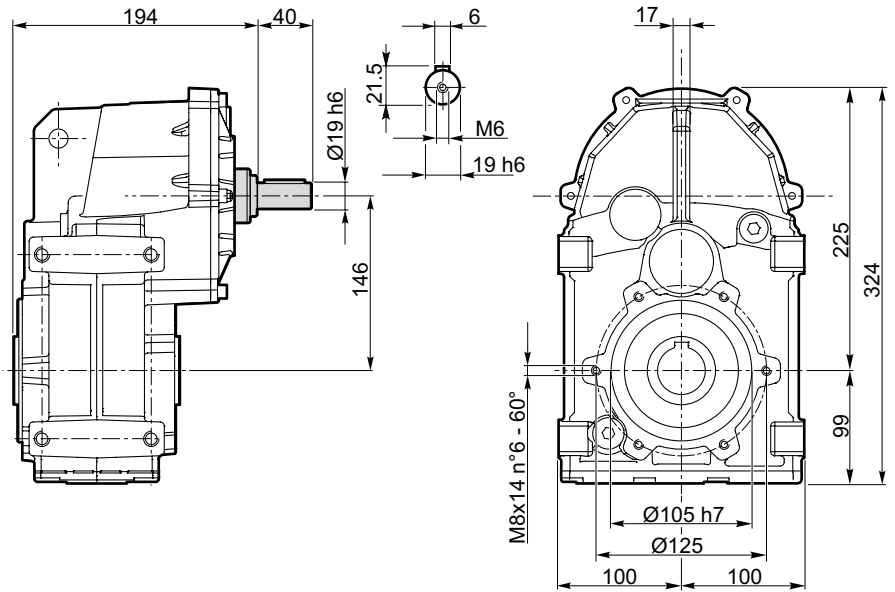

ATS 912 F..

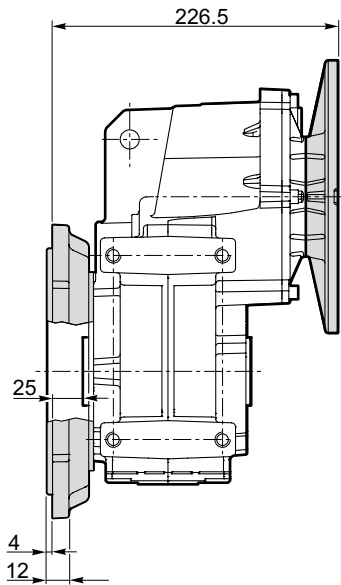

ATSIS 912 F..

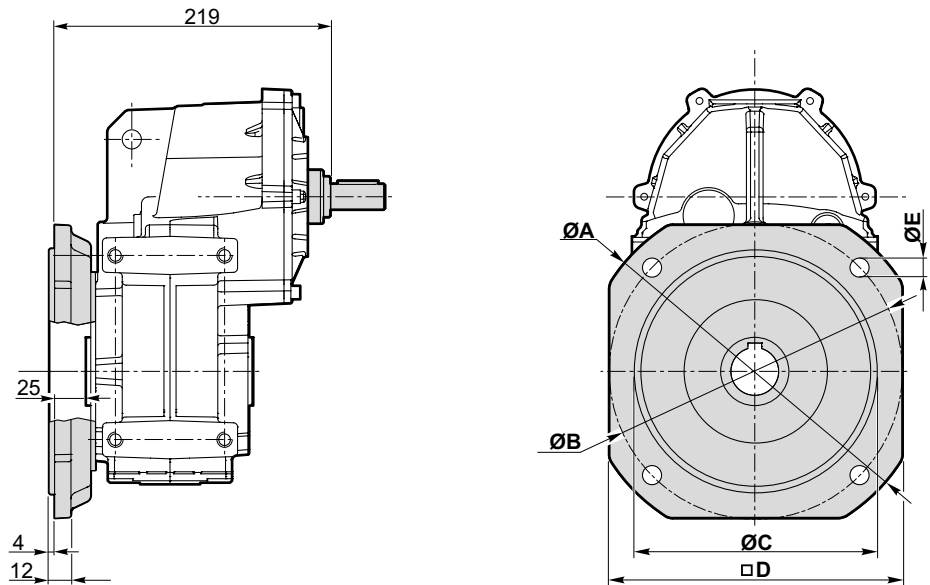

Versione F / F Version							
ATS ATSIS	ØA	ØB	ØC f7	□D	ØE	Flangia / Flange	
						Tipo / Type	Peso / Weight [kg]
912	200	165	130	165	11	F200	2
	250	215	180	215	14	F250	3.2

ATS 912.. D40 - ATSIS 912.. D40

Flangia entrata
Input flange

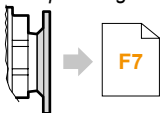

Albero uscita cavo
Hollow output shaft

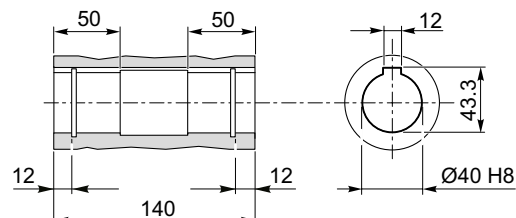

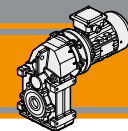

Dimensioni

Dimensions

ATS 913

ATS 913 U..

ATSIS 913 U..

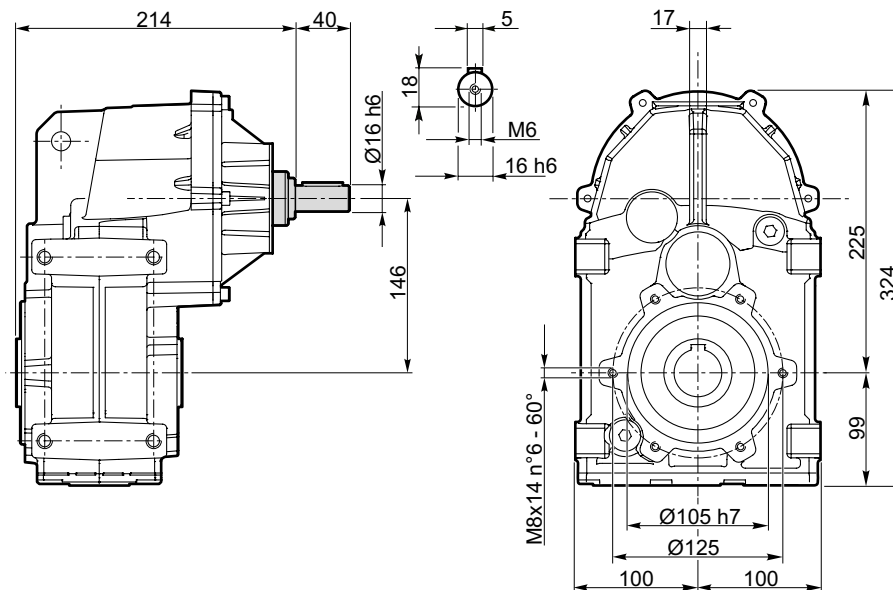
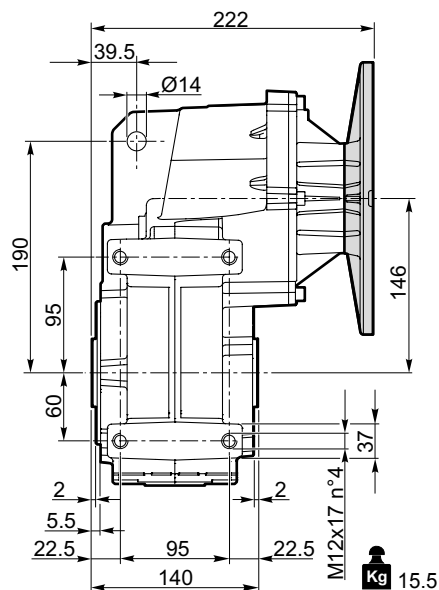

ATS 913 F..

ATSIS 913 F..

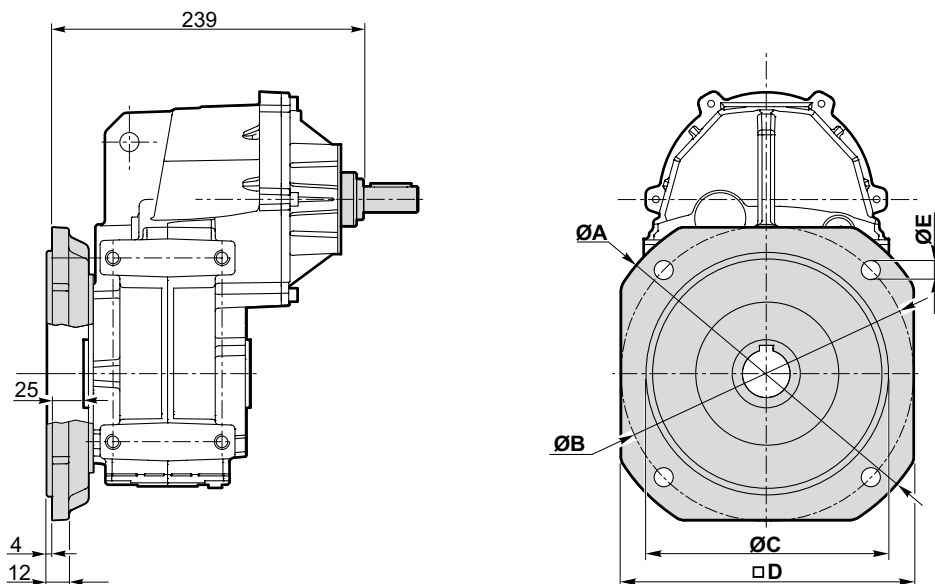
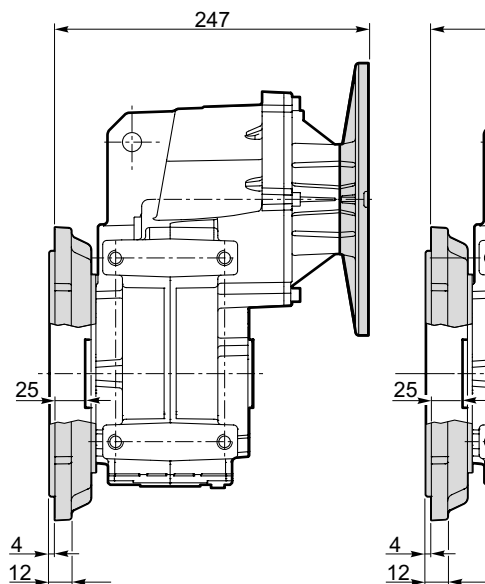

Versione F / F Version							
ATS ATSIS	ØA	ØB	ØC f7	□D	ØE	Flangia / Flange	
						Tipo / Type	Peso / Weight [kg]
913	200	165	130	165	11	F200	2
	250	215	180	215	14	F250	3.2

ATS 913.. D40 - ATSIS 913.. D40

Flangia entrata
Input flange



Albero uscita cavo
Hollow output shaft

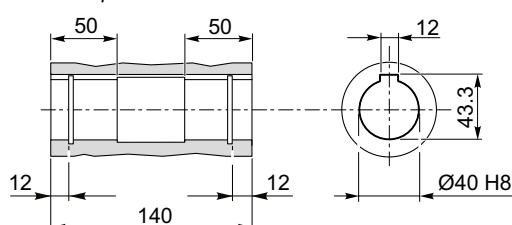

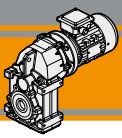

Accessori

Accessories

Albero lento semplice

Single output shaft

ATS90... U .. SZ

ATSIS90... U .. SZ

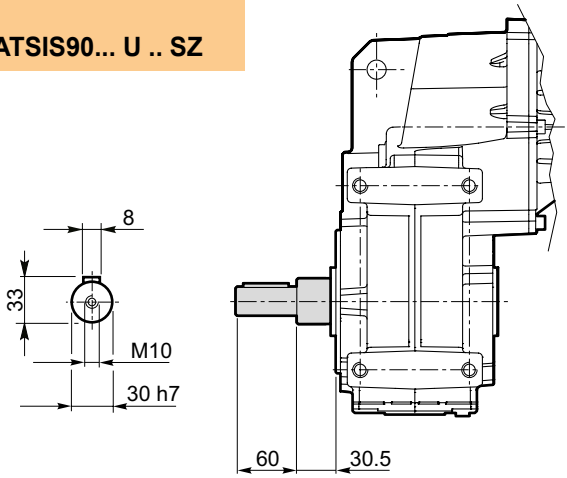

ATS90... F .. SZ

ATSIS90... F .. SZ

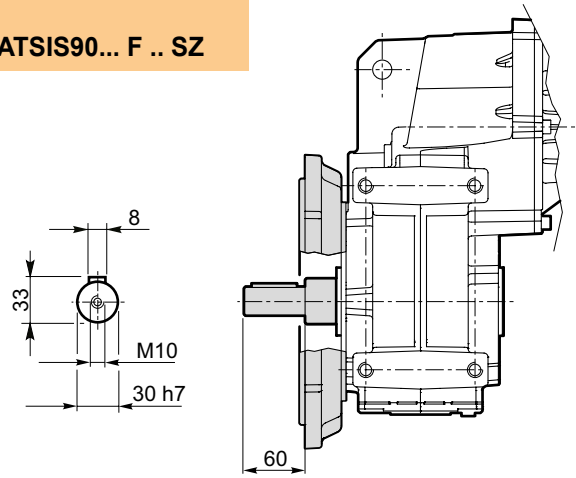

ATS91... U .. SZ

ATSIS91... U .. SZ

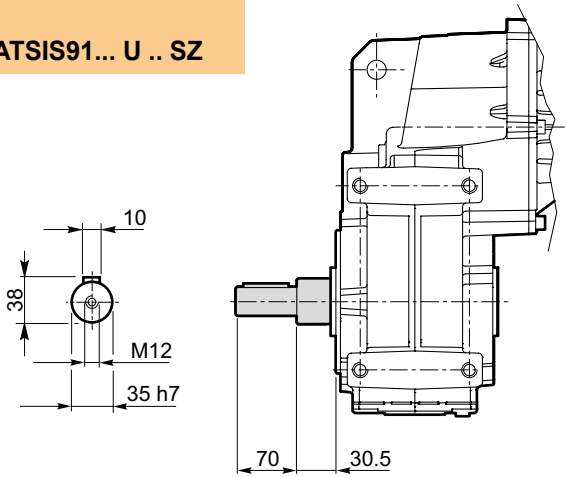

ATS91... F .. SZ

ATSIS91... F .. SZ

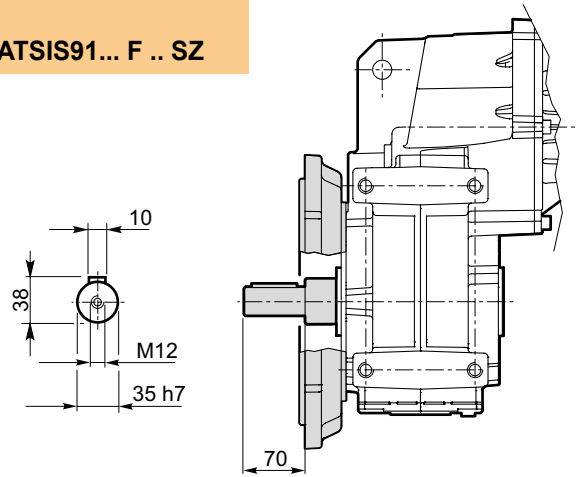

Albero lento con calettatore

Output shaft with shrink disk

ATS90... U .. G35

ATSIS90... U .. G35

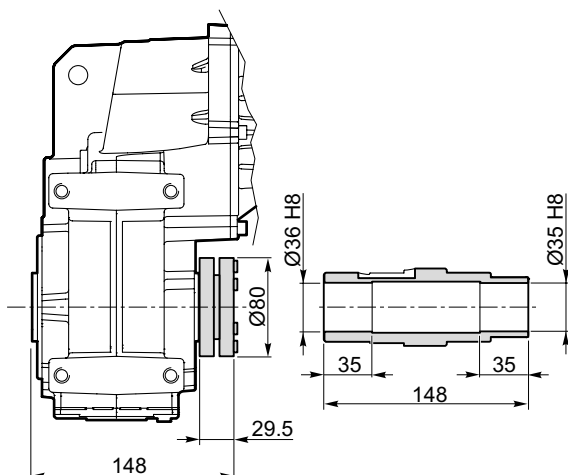

ATS91... U .. G40

ATSIS91... U .. G40

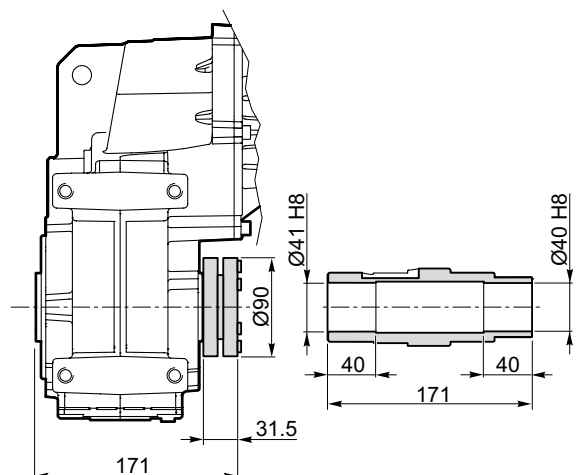

Kit albero uscita con calettatore disponibile a richiesta:
per le istruzioni di montaggio riferirsi al nostro Servizio Tecnico.

Output shaft kit with shrink disk available on request:
for assembly instructions please contact our Technical Service

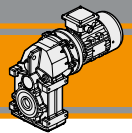

Accessori

Accessories

Kit di montaggio albero uscita

Output shaft assembly kit

ATS90...
ATS91...
ATSIS90...
ATSIS91...

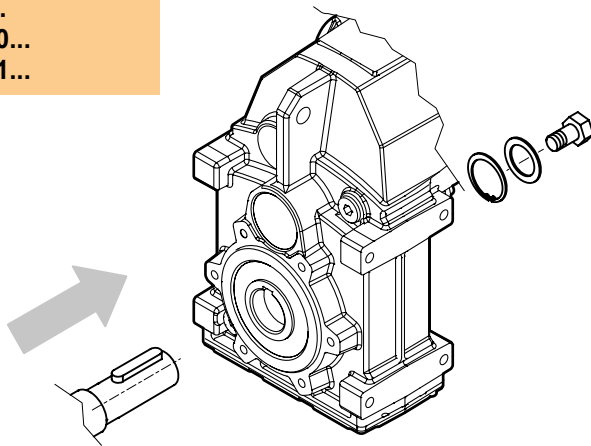

Kit di montaggio albero uscita disponibile a richiesta:
per le istruzioni di montaggio riferirsi al nostro Servizio Tecnico.

*Output shaft assembly kit available upon request:
for assembly instructions please contact our Technical Assistance*

Kit di smontaggio albero uscita

Output shaft disassembly kit

ATS90...
ATS91...
ATSIS90...
ATSIS91...

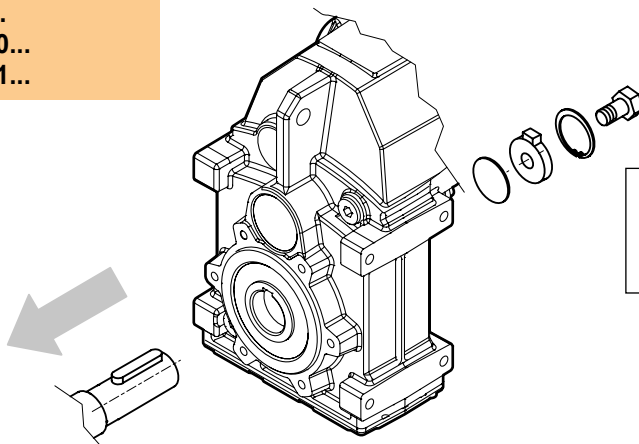

Kit di smontaggio albero uscita disponibile a richiesta:
per le istruzioni di montaggio riferirsi al nostro Servizio Tecnico.

*Output shaft disassembly kit available upon request:
for assembly instructions please contact our Technical Assistance*

Kit braccio di reazione

Torque arm kit

ATS90...U
ATS91...U
ATSIS90...U
ATSIS91...U

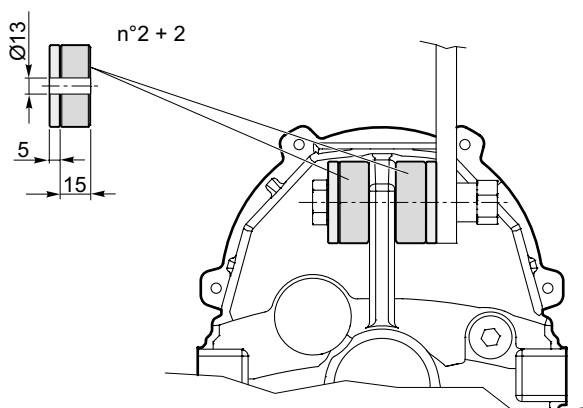

Kit braccio di reazione disponibile a richiesta:
per le istruzioni di montaggio riferirsi al nostro Servizio Tecnico.

*Torque arm kit available upon request:
for assembly instructions please contact our Technical Assistance*

ATS

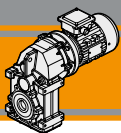

Архангельск (8182)63-90-72
Астана (7172)727-132
Белгород (4722)40-23-64
Брянск (4832)59-03-52
Владивосток (423)249-28-31
Волгоград (844)278-03-48
Вологда (8172)26-41-59
Воронеж (473)204-51-73
Екатеринбург (343)384-55-89
Иваново (4932)77-34-06
Ижевск (3412)26-03-58
Казань (843)206-01-48

Калининград (4012)72-03-81
Калуга (4842)92-23-67
Кемерово (3842)65-04-62
Киров (8332)68-02-04
Краснодар (861)203-40-90
Красноярск (391)204-63-61
Курск (4712)77-13-04
Липецк (4742)52-20-81
Магнитогорск (3519)55-03-13
Москва (495)268-04-70
Мурманск (8152)59-64-93
Набережные Челны (8552)20-53-41

Нижний Новгород (831)429-08-12
Новокузнецк (3843)20-46-81
Новосибирск (383)227-86-73
Орел (4862)44-53-42
Оренбург (3532)37-68-04
Пенза (8412)22-31-16
Пермь (342)205-81-47
Ростов-на-Дону (863)308-18-15
Рязань (4912)46-61-64
Самара (846)206-03-16
Санкт-Петербург (812)309-46-40
Саратов (845)249-38-78

Смоленск (4812)29-41-54
Сочи (862)225-72-31
Ставрополь (8652)20-65-13
Тверь (4822)63-31-35
Томск (3822)98-41-53
Тула (4872)74-02-29
Тюмень (3452)66-21-18
Ульяновск (8422)24-23-59
Уфа (347)229-48-12
Челябинск (351)202-03-61
Череповец (8202)49-02-64
Ярославль (4852)69-52-93