

CMG

CMG

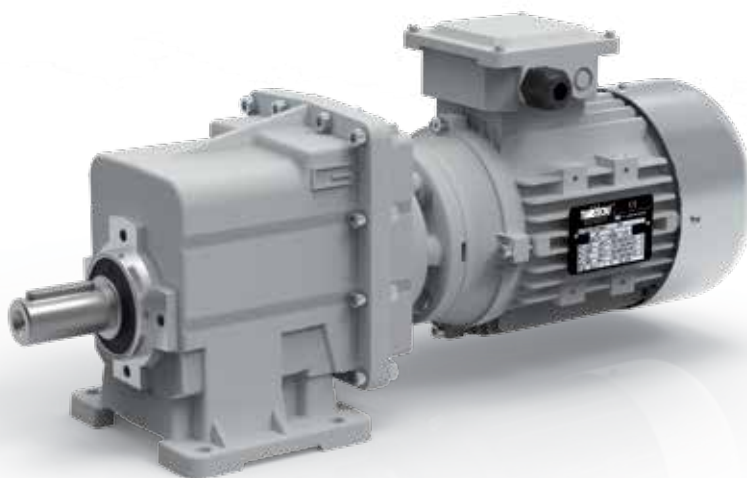

Цилиндрические мотор-редукторы Руководство по эксплуатации



Архангельск (8182)63-90-72
Астана (7172)727-132
Белгород (4722)40-23-64
Брянск (4832)59-03-52
Владивосток (423)249-28-31
Волгоград (844)278-03-48
Вологда (8172)26-41-59
Воронеж (473)204-51-73
Екатеринбург (343)384-55-89
Иваново (4932)77-34-06
Ижевск (3412)26-03-58
Казань (843)206-01-48

Калининград (4012)72-03-81
Калуга (4842)92-23-67
Кемерово (3842)65-04-62
Киров (8332)68-02-04
Краснодар (861)203-40-90
Красноярск (391)204-63-61
Курск (4712)77-13-04
Липецк (4742)52-20-81
Магнитогорск (3519)55-03-13
Москва (495)268-04-70
Мурманск (8152)59-64-93
Набережные Челны (8552)20-53-41

Нижний Новгород (831)429-08-12
Новокузнецк (3843)20-46-81
Новосибирск (383)227-86-73
Орел (4862)44-53-42
Оренбург (3532)37-68-04
Пенза (8412)22-31-16
Пермь (342)205-81-47
Ростов-на-Дону (863)308-18-15
Рязань (4912)46-61-64
Самара (846)206-03-16
Санкт-Петербург (812)309-46-40
Саратов (845)249-38-78

Смоленск (4812)29-41-54
Сочи (862)225-72-31
Ставрополь (8652)20-65-13
Тверь (4822)63-31-35
Томск (3822)98-41-53
Тула (4872)74-02-29
Тюмень (3452)66-21-18
Ульяновск (8422)24-23-59
Уфа (347)229-48-12
Челябинск (351)202-03-61
Череповец (8202)49-02-64
Ярославль (4852)69-52-93

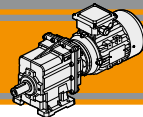

Indice	Index	Pag. Page
Caratteristiche tecniche	<i>Technical features</i>	B2
Designazione	<i>Classification</i>	B3
Sensi di rotazione	<i>Direction of rotation</i>	B4
Simbologia	<i>Symbols</i>	B4
Lubrificazione	<i>Lubrication</i>	B4
Carichi radiali	<i>Radial loads</i>	B5
Dati tecnici	<i>Technical data</i>	B6
Dimensioni	<i>Dimensions</i>	B18

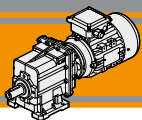
**Caratteristiche tecniche**

I motoriduttori ad ingranaggi cilindrici della serie CMG sono caratterizzati da un elevato grado di modularità: partendo da un corpo di base è possibile configurarlo secondo le esigenze, con flangia o piede.

Caratteristiche comuni a tutta la serie:

- Carcassa e flangia PAM in pressofusione di alluminio per le taglie 00, 01, 02, 03 e 04.
- Piedi e flange d'uscita in ghisa;
- Ingranaggi sempre rettificati;
- Lubrificazione permanente con olio sintetico.

Technical features

The high degree of modularity is a design feature of CMG helical in-line gearmotors range. It is possible to set up the version required using flanges or feet.

The main features of CMG range are:

- *Die-cast aluminum housings and input flanges for sizes 00, 01, 02, 03 and 04.*
- *Cast iron feet and output flanges;*
- *Ground-hardened helical gears;*
- *Permanent synthetic oil long-life lubrication.*

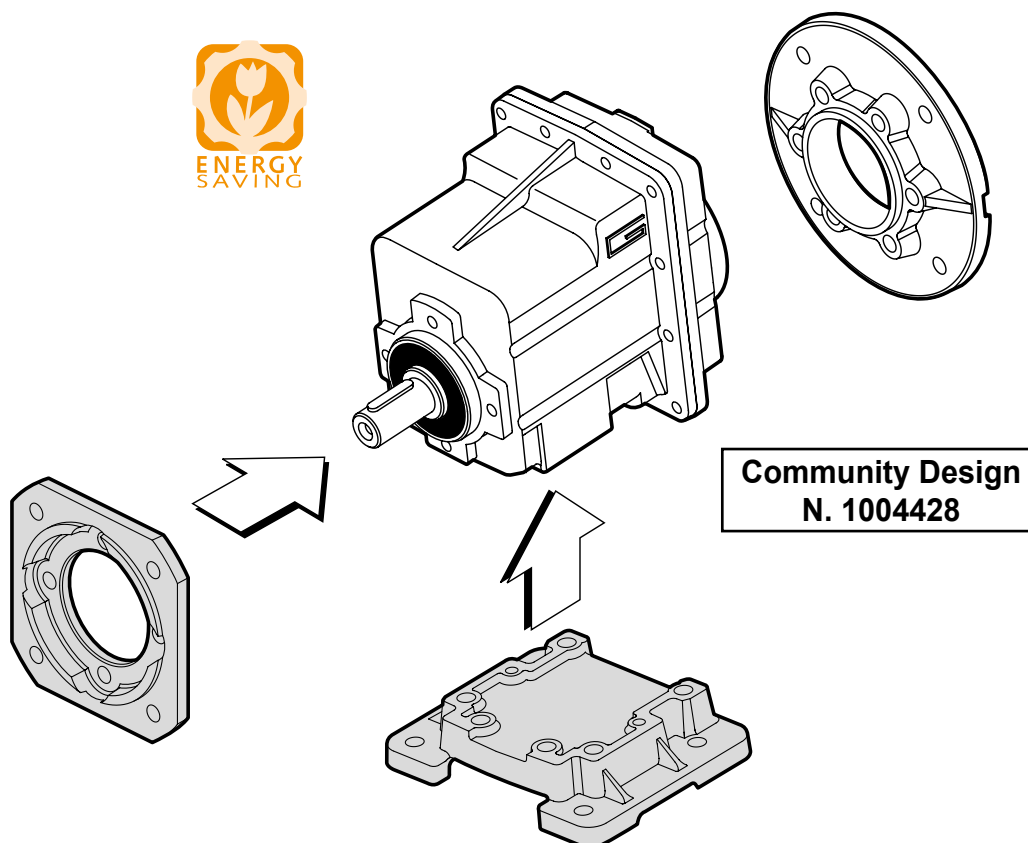

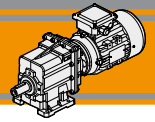

Designazione

Classification

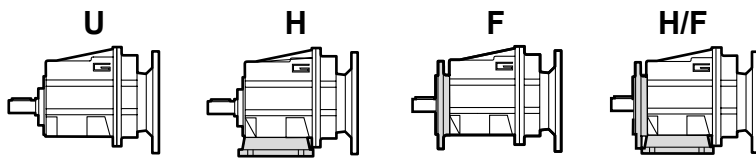

CMG

RIDUTTORE / GEARBOX

CMG	01	2	H65	9.81	D20	71	B14
Tipo Type	Grandezza Size	Stadi Stages	Versione Version	Rapporto Ratio	Albero uscita Output shaft	IEC 	Forma costruttiva Version
CMG	00 01 02 03 04	2 3	U... H... F... H.../F...	vedi tabelle see tables	vedi tabelle see tables	56.. — 112..	B5 B14

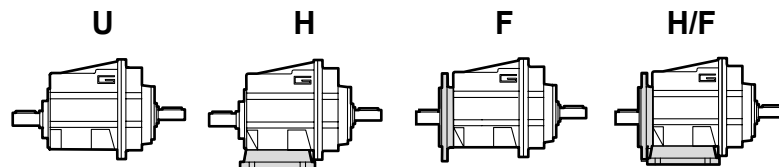

RIDUTTORE / GEARBOX

CMGIS	01	2	U	9.81	D20
Tipo Type	Grandezza Size	Stadi Stages	Versione Version	Rapporto Ratio	Albero uscita Output shaft
CMGIS	01 02 03 04	2 3	U... H... F... H.../F...	vedi tabelle see tables	vedi tabelle see tables

MOTORE / MOTOR

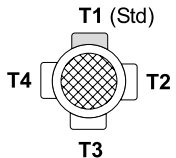
0.75kW	4p	3ph	230/400V	50Hz	T1
Potenza Power	Poli Poles	Fasi Phases	Tensione Voltage	Frequenza Frequency	Pos. morsetti Terminal box pos.
vedi tabelle see tables	2p 4p 6p 8p	1ph 3ph	230V 230/400V	50Hz 60Hz	T1 (Std) 

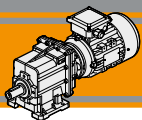
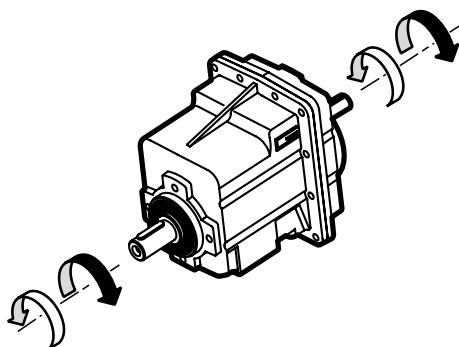
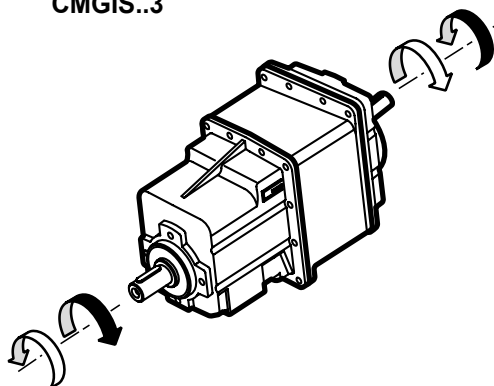
**Sensi di rotazione****Direction of rotation****CMG...2**
CMGIS..2**CMG...3**
CMGIS..3**Simbologia****Symbols**

n_1	[min ⁻¹]	Velocità in ingresso / <i>Input speed</i>
n_2	[min ⁻¹]	Velocità in uscita / <i>Output speed</i>
i		Rapporto di riduzione / <i>Ratio</i>
P_1	[kW]	Potenza in entrata / <i>Input power</i>
M_2	[Nm]	Coppia nominale in uscita in funzione di P_1 / <i>Output torque referred to P_1</i>
P_{n1}	[kW]	Potenza nominale in entrata / <i>Nominal input power</i>
M_{n2}	[Nm]	Coppia nominale in uscita in funzione di P_{n1} / <i>Nominal output torque referred to P_{n1}</i>
sf		Fattore di servizio / <i>Service factor</i>
R_2	[N]	Carico radiale ammissibile in uscita / <i>Permitted output radial load</i>
A_2	[N]	Carico assiale ammissibile in uscita / <i>Permitted output axial load</i>

Lubrificazione**Lubrication**

Tutti i motoriduttori nelle taglie 00, 01, 02, 03 e 04 sono forniti completi di lubrificante sintetico viscosità 320, pertanto possono essere installati in qualunque posizione di montaggio e non necessitano di manutenzione.

Permanent synthetic oil long-life lubrication (viscosity grade 320) makes it possible to use sizes 00, 01, 02, 03 and 04 in all mounting positions; for this reason they can be installed in any assembly position and do not require maintenance.

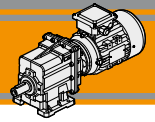

Carichi radiali

Radial loads

CMG

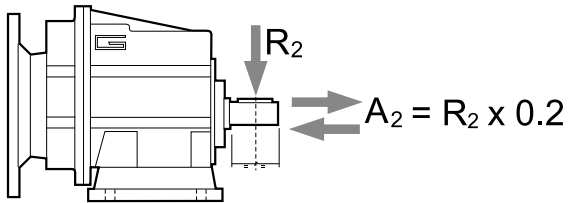

n ₂ [min ⁻¹]	R ₂ [N]				
	CMG 00	CMG 01	CMG 02	CMG 03	CMG 04
700	416	764	1529	1987	2379
600	437	805	1609	2092	2504
500	465	855	1710	2223	2661
400	501	921	1842	2395	2866
250	586	1077	2154	2801	3353
180	653	1323	2554	3321	3897
150	748	1406	2714	3529	4244
120	806	1631	3467	3801	4572
100	958	1842	3684	4507	5234
80	1032	1984	3969	5042	5991
60	1136	2184	4368	5549	6594
40	1300	2500	5000	6500	8000
10	1300	2500	5000	6500	8000

Quando il carico radiale risultante non è applicato sulla mezzeria dell'albero occorre calcolare quello effettivo con la seguente formula:

When the resulting radial load is not applied on the centre line of the shaft it is necessary to calculate the effective load with the following formula:

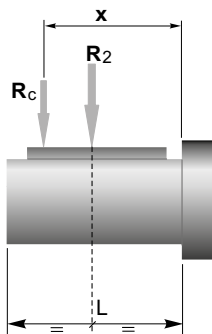

	CMG 00	CMG 01	CMG 02	CMG 03	CMG 04
a	73	104	117	132	150
b	53	84	92	102	115
R _{2MAX}	1300	2500	5000	6500	8000

$$R_c = \frac{R_2 \cdot a}{(b + x)} \leq R_{2MAX}$$

a, b = valori riportati nella tabella
a, b = values given in the table

$$R \leq R_c$$

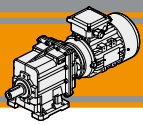

Dati tecnici

n_1 1400 min⁻¹

Technical data

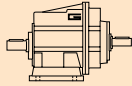
	n_2 [min ⁻¹]	Mn_2 [Nm]	Pn_1 [kW]	i	IEC Motori applicabili IEC Motor adapters			
					56 B5/B14	63 B5/B14	71 B5/B14	80 B5/B14
CMGIS 002								
	279	40	1.2	5.03				
	230	40	1.0	6.10				
	187	40	0.82	7.49				
	156	50	0.85	8.99				
	138	50	0.75	10.16				
	116	50	0.63	12.07				
	105	70	0.80	13.40				
	92.5	70	0.71	15.14				
	77.1	70	0.59	18.17				
	64.9	70	0.50	21.58				
	59.6	70	0.45	23.51				
	55.8	70	0.43	25.10				*
	51.7	70	0.39	27.08				*
	43.1	70	0.33	32.49				*
	33.3	70	0.25	42.04				*
	31.2	70	0.24	44.89				*
	28.7	70	0.22	48.86				*
	25.4	70	0.19	55.10				*

N.B.
 Le aree evidenziate indicano l'applicabilità della corrispondente grandezza motore.

N.B.
 Highlighted areas indicate motor inputs available on each size of unit.



* = Il fattore di servizio (**sf**) deve essere scelto in funzione dell'applicazione: si prega di contattare il nostro Servizio Tecnico.

Prima di eseguire la scelta del motoriduttore riferirsi alle prestazioni elencate nelle tabelle dalla pag. B11 alla pag. B17



* = The service factor (**sf**) has to be selected depending on application: please contact our Technical Department.

Before selecting any gearbox, please read the performance values shown in the tables on page B11 to B17.

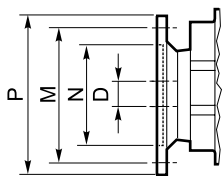

Dimensioni IEC / IEC Dimensions								
	56 B5	56 B14	63 B5	63 B14	71 B5	71 B14	80 B5	80 B14
N	80	50	95	60	110	70	130	80
M	100	65	115	75	130	85	165	100
P	120	80	140	90	160	105	200	120
D	9		11		14		19	

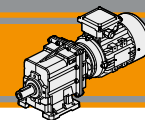

Dati tecnici

n_1 1400 min⁻¹

Technical data

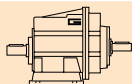
	n_2 [min ⁻¹]	Mn_2 [Nm]	Pn_1 [kW]	i	IEC Motori applicabili IEC Motor adapters			
					63 B5	71 B5/B14	80 B5/B14	90 B5/B14
CMGIS 012								
	367	60	2.4	3.82				
	302	60	2.0	4.63				
	246	60	1.6	5.69				
	181	80	1.6	7.72				
	153	80	1.3	9.17				
	143	80	1.2	9.81				
	122	100	1.3	11.50				
	118	100	1.3	11.90				
	101	120	1.3	13.80				
	95.7	120	1.3	14.62				
	78.4	120	1.0	17.86				
	73.4	120	1.0	19.07				
	70.6	120	0.92	19.83				
	59.4	120	0.78	23.56				*
	47.4	120	0.62	29.56				*
	39.5	120	0.52	35.47				*
	30.5	120	0.40	45.89			*	*
	28.6	120	0.37	49.00			*	*
	26.3	120	0.34	53.33			*	*
	23.3	120	0.30	60.15			*	*

	n_2 [min ⁻¹]	Mn_2 [Nm]	Pn_1 [kW]	i	IEC Motori applicabili IEC Motor adapters			
					63 B5	71 B5/B14	80 B5/B14	90 B5/B14
CMGIS 013								
	22.1	120	0.30	63.22			*	*
	18.6	120	0.25	75.08			*	*
	15.7	120	0.21	89.17			*	*
	12.4	120	0.17	113.05			*	*
	10.4	120	0.14	134.27		*	*	*
	8.1	120	0.11	173.72		*	*	*
	6.9	120	0.09	202.16		*	*	*
	5.4	120	0.07	261.57		*	*	*
	4.6	120	0.06	304.00		*	*	*
	3.6	120	0.05	393.33		*	*	*
	3.2	120	0.04	443.59		*	*	*

N.B.
Le aree evidenziate indicano l'applicabilità della corrispondente grandezza motore.

N.B.
Highlighted areas indicate motor inputs available on each size of unit.

 * = Il fattore di servizio (sf) deve essere scelto in funzione dell'applicazione: si prega di contattare il nostro Servizio Tecnico.

 * = The service factor (sf) has to be selected depending on application: please contact our Technical Department.

Prima di eseguire la scelta del motoriduttore riferirsi alle prestazioni elencate nelle tabelle dalla pag. B11 alla pag. B17

Before selecting any gearbox, please read the performance values shown in the tables on page B11 to B17.

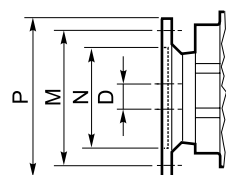

Dimensioni IEC / IEC Dimensions							
	63 B5	71 B5	71 B14	80 B5	80 B14	90 B5	90 B14
N	95	110	70	130	80	130	95
M	115	130	85	165	100	165	115
P	140	160	105	200	120	200	140
D	11	14		19		24	

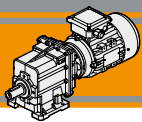

Dati tecnici

n_1 1400 min⁻¹

Technical data

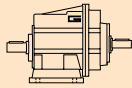
	n_2 [min ⁻¹]	Mn_2 [Nm]	Pn_1 [kW]	i	IEC Motori applicabili IEC Motor adapters			
					63 B5	71 B5/B14	80 B5/B14	90 B5/B14
CMGIS 022								
	383	100	4.2	3.66				
	316	100	3.4	4.43				
	257	100	2.8	5.45				
	190	120	2.5	7.39				
	159	120	2.1	8.78				
	141	120	1.8	9.93				
	127	200	2.8	11.01				
	116	200	2.5	12.05				
	106	200	2.3	13.21				
	94.6	200	2.1	14.81				
	81.9	160	1.4	17.10				
	76.7	160	1.3	18.26				
	69.7	200	1.5	20.08				
	58.7	200	1.3	23.85				
	46.8	200	1.0	29.93				
	39.0	200	0.85	35.91				
	30.1	200	0.66	46.46				*
	28.2	200	0.62	49.61				*
	25.9	200	0.57	54.00				*
	23.0	200	0.50	60.90				*

	n_2 [min ⁻¹]	Mn_2 [Nm]	Pn_1 [kW]	i	IEC Motori applicabili IEC Motor adapters			
					63 B5	71 B5/B14	80 B5/B14	90 B5/B14
CMGIS 023								
	21.9	200	0.49	64.01				*
	18.4	200	0.41	76.02			*	*
	15.5	200	0.35	90.29			*	*
	12.2	200	0.27	114.46			*	*
	10.3	200	0.23	135.95			*	*
	8.0	200	0.18	175.89		*	*	*
	6.8	200	0.15	204.69		*	*	*
	5.3	200	0.12	264.84		*	*	*
	4.5	200	0.10	307.80		*	*	*
	3.5	200	0.08	398.25		*	*	*
	3.1	200	0.07	449.14		*	*	*

N.B.
 Le aree evidenziate indicano l'applicabilità della corrispondente grandezza motore.

N.B.
 Highlighted areas indicate motor inputs available on each size of unit.

 * = Il fattore di servizio (sf) deve essere scelto in funzione dell'applicazione: si prega di contattare il nostro Servizio Tecnico.

 * = The service factor (sf) has to be selected depending on application: please contact our Technical Department.

Prima di eseguire la scelta del motoriduttore riferirsi alle prestazioni elencate nelle tabelle dalla pag. B11 alla pag. B17

Before selecting any gearbox, please read the performance values shown in the tables on page B11 to B17.

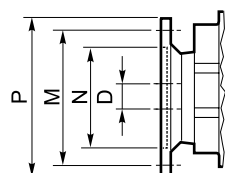

Dimensioni IEC / IEC Dimensions							
	63 B5	71 B5	71 B14	80 B5	80 B14	90 B5	90 B14
N	95	110	70	130	80	130	95
M	115	130	85	165	100	165	115
P	140	160	105	200	120	200	140
D	11	14		19		24	

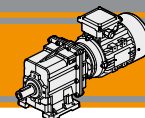

Dati tecnici

n_1 1400 min⁻¹

Technical data

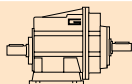
	n_2 [min ⁻¹]	Mn_2 [Nm]	Pn_1 [kW]	i	IEC Motori applicabili IEC Motor adapters					
					71 B5	80 B5/B14	90 B5/B14	100 B5/B14	112 B5/B14	
CMGIS 032										
	374	150	6.1	3.74	B					
	311	150	5.1	4.50	B					
	255	150	4.2	5.48	B					
	222	180	4.4	6.31	B					
	177	180	3.5	7.93	B					
	154	180	3.0	9.08	B					*
	128	180	2.5	10.93	B					*
	111	250	3.0	12.60	B					*
	105	250	2.9	13.30	B					*
	91.5	280	2.8	15.30	B					*
	76.9	280	2.3	18.21	B					*
	72.8	280	2.2	19.24	B					*
	66.2	280	2.0	21.15	B					*
	56.0	300	1.8	24.99	B					*
	45.8	300	1.5	30.57	B			*		*
	40.9	300	1.3	34.20	B			*		*
	36.2	300	1.2	38.63	B			*		*
	31.7	300	1.0	44.18	B			*		*
	27.3	300	0.89	51.30	B		*	*		*
	23.0	300	0.75	60.80	B		*	*		*

	n_2 [min ⁻¹]	Mn_2 [Nm]	Pn_1 [kW]	i	IEC Motori applicabili IEC Motor adapters				
					63 B5	71 B5/B14	80 B5/B14	90 B5/B14	
CMGIS 033									
	19.2	300	0.64	72.83					*
	14.4	300	0.48	97.45					*
	12.1	300	0.40	115.74			*		*
	9.9	300	0.33	140.81			*		*
	8.0	300	0.27	174.26			*		*
	6.2	300	0.21	225.47			*		*
	5.3	300	0.18	262.05		*	*		*
	4.3	300	0.14	325.79		*	*		*
	3.7	300	0.12	378.64		*	*		*
	3.3	300	0.11	427.03		*	*		*

N.B.
Le aree evidenziate indicano l'applicabilità della corrispondente grandezza motore.
B = Boccola di riduzione in acciaio.

N.B.
Highlighted areas indicate motor inputs available on each size of unit.
B = Metal shaft sleeve.

 * = Il fattore di servizio (sf) deve essere scelto in funzione dell'applicazione: si prega di contattare il nostro Servizio Tecnico.

 * = The service factor (sf) has to be selected depending on application: please contact our Technical Department.

Prima di eseguire la scelta del motoriduttore riferirsi alle prestazioni elencate nelle tabelle dalla pag. B11 alla pag. B17

Before selecting any gearbox, please read the performance values shown in the tables on page B11 to B17.

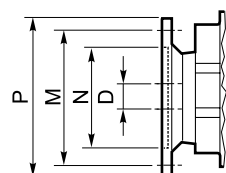

Dimensioni IEC / IEC Dimensions									
	63 B5	71 B5	71 B14	80 B5	80 B14	90 B5	90 B14	100/112 B5	100/112 B14
N	95	110	70	130	80	130	95	180	110
M	115	130	85	165	100	165	115	215	130
P	140	160	105	200	120	200	140	250	160
D	11	14		19		24		28	

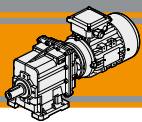

Dati tecnici

n_1 1400 min⁻¹

Technical data

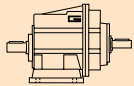
	n_2 [min ⁻¹]	Mn_2 [Nm]	Pn_1 [kW]	i	IEC Motori applicabili IEC Motor adapters				
					71 B5	80 B5/B14	90 B5/B14	100 B5/B14	112 B5/B14
CMGIS 042									
	374	230	9.4	3.74	B				
	311	230	7.8	4.50	B				
	255	230	6.4	5.48	B				
	222	260	6.3	6.31	B				
	177	260	5.0	7.93	B				
	154	280	4.7	9.08	B				
	128	280	3.9	10.93	B				
	111	350	4.2	12.60	B				
	105	350	4.0	13.30	B				
	91.5	420	4.2	15.30	B				
	76.9	420	3.5	18.21	B				
	72.8	420	3.3	19.24	B				
	56.0	500	3.1	24.99	B				
	45.8	500	2.5	30.57	B				*
	40.9	500	2.2	34.20	B				*
	36.2	500	2.0	38.63	B				*
	31.7	500	1.7	44.18	B		*		*
	27.3	500	1.5	51.30	B		*		*
	23.0	480	1.2	60.80	B		*		*

		n_2	Mn_2	Pn_1	i	IEC Motori applicabili IEC Motor adapters			
						63 B5	71 B5/B14	80 B5/B14	90 B5/B14
CMGIS 043									
	19.2	500	1.1	72.83					
	14.4	500	0.80	97.45					*
	12.1	500	0.67	115.74					*
	9.9	500	0.55	140.81					*
	8.0	500	0.45	174.26					*
	6.2	500	0.35	225.47			*		*
	5.3	500	0.30	262.05			*		*
	4.3	500	0.24	325.79			*		*
	3.7	500	0.21	378.64			*		*
	3.3	500	0.18	427.03		*	*		*

N.B.
Le aree evidenziate indicano l'applicabilità della corrispondente grandezza motore.
B = Boccola di riduzione in acciaio.

 * = Il fattore di servizio (**sf**) deve essere scelto in funzione dell'applicazione: si prega di contattare il nostro Servizio Tecnico.

Prima di eseguire la scelta del motoriduttore riferirsi alle prestazioni elencate nelle tabelle dalla pag. B11 alla pag. B17

N.B.
Highlighted areas indicate motor inputs available on each size of unit.
B = Metal shaft sleeve.

 * = The service factor (**sf**) has to be selected depending on application: please contact our Technical Department.

Before selecting any gearbox, please read the performance values shown in the tables on page B11 to B17.

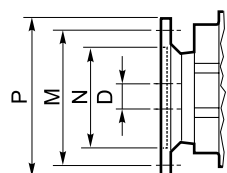



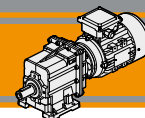

Dimensioni IEC / IEC Dimensions									
	63 B5	71 B5	71 B14	80 B5	80 B14	90 B5	90 B14	100/112 B5	100/112 B14
N	95	110	70	130	80	130	95	180	110
M	115	130	85	165	100	165	115	215	130
P	140	160	105	200	120	200	140	250	160
D	11	14		19		24		28	

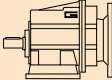

Dati tecnici

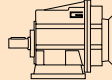
Technical data

P ₁ [kW]	n ₂ [min ⁻¹]	M ₂ [Nm]	sf	i			P ₁ [kW]	n ₂ [min ⁻¹]	M ₂ [Nm]	sf	i				
0.06							0.12								
56A4 (1400 min ⁻¹)	279	2	20.3	5.03	CMG002	B5/B14	63A4 (1400 min ⁻¹)	30.5	36	3.3	45.89	CMG012	B5		
	230	2	16.7	6.10				28.6	39	3.1	49.00				
	187	3	13.6	7.49				26.3	42	2.9	53.33				
	156	4	14.2	8.99				23.3	47	2.5	60.15				
	138	4	12.5	10.16											
	116	5	10.5	12.07				22.1	49	2.5	63.22			CMG013	B5
	105	5	13.3	13.40				18.6	58	2.1	75.08				
	92.5	6	11.8	15.14				15.7	69	1.7	89.17				
	77.1	7	9.8	18.17				12.4	87	1.4	113.05				
	64.9	8	8.3	21.58				10.4	103	1.2	134.27				
	59.6	9	7.6	23.51				8.1	134	0.9	173.72				
	55.8	10	7.1	25.10				6.9	156	0.8	202.16				
	51.7	11	6.6	27.08				5.4	171	0.7	261.57				
	43.1	13	5.5	32.49				4.6	171	0.7	304.00				
	33.3	17	4.2	42.04				3.6	171	0.7	393.33				
	31.2	18	4.0	44.89				3.2	171	0.7	443.59				
	28.7	19	3.6	48.86										CMG023	B5
	25.4	22	3.2	55.10				21.9	49	4.1	64.01				
								18.4	58	3.4	76.02				
								15.5	69	2.9	90.29				
								12.2	88	2.3	114.46				
								10.3	105	1.9	135.95				
						8.0	135	1.5	175.89						
						6.8	157	1.3	204.69						
						5.3	204	1.0	264.84						
						4.5	237	0.8	307.80						
						3.5	285	0.7	398.25						
						3.1	285	0.7	449.14						
						19.2	56	5.4	72.83	CMG033	B5				
						14.4	75	4.0	97.45						
						12.1	89	3.4	115.74						
						9.9	108	2.8	140.81						
						8.0	134	2.2	174.26						
						6.2	173	1.7	225.47						
						5.3	202	1.5	262.05						
						4.3	251	1.2	325.79						
						3.7	291	1.0	378.64						
						3.3	329	0.9	427.03						
						19.2	56	8.9	72.83	CMG043	B5				
						14.4	75	6.7	97.45						
						12.1	89	5.6	115.74						
						9.9	108	4.6	140.81						
						8.0	134	3.7	174.26						
						6.2	173	2.9	225.47						
						5.3	202	2.5	262.05						
						4.3	251	2.0	325.79						
						3.7	291	1.7	378.64						
						3.3	329	1.5	427.03						
										CMG012	B5				
	59.4	19	6.5	23.56											
	47.4	23	5.2	29.56											
	39.5	28	4.3	35.47											

CMG

N.B.
Verificare sempre che la coppia M2 utilizzata non ecceda il valore indicato nelle caselle in grigio

N.B.
Please check that the output torque M2 does not exceed the value in the grey areas

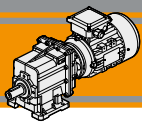





CMG

Motoriduttori ad ingranaggi cilindrici
Helical in-line gearmotors

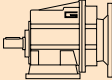
Dati tecnici

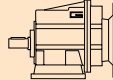

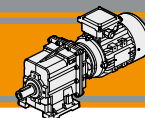

Technical data

P_1 [kW]	n_2 [min ⁻¹]	M_2 [Nm]	sf	i			P_1 [kW]	n_2 [min ⁻¹]	M_2 [Nm]	sf	i								
0.18							0.25												
63B4 (1400 min ⁻¹)	279	6	6.8	5.03	CMG002	B5/B14	71A4 (1400 min ⁻¹)	279	8	4.9	5.03	CMG002	B5/B14						
	230	7	5.6	6.10						230	10			4.0	6.10		B5/B14		
	187	9	4.5	7.49						187	12			3.3	7.49		B5/B14		
	156	11	4.7	8.99						156	15			3.4	8.99		B5/B14		
	138	12	4.2	10.16						138	17			3.0	10.16		B5/B14		
	116	14	3.5	12.07						116	20			2.5	12.07		B5/B14		
	105	16	4.4	13.40						105	22			3.2	13.40		B5/B14		
	92.5	18	3.9	15.14						92.5	25			2.8	15.14		B5/B14		
	77.1	21	3.3	18.17						77.1	30			2.4	18.17		B5/B14		
	64.9	25	2.8	21.58						64.9	35			2.0	21.58		B5/B14		
	59.6	28	2.5	23.51						59.6	38			1.8	23.51		B5/B14		
	55.8	30	2.4	25.10						55.8	41			1.7	25.10		B5/B14		
	51.7	32	2.2	27.08						51.7	44			1.6	27.08		B5/B14		
	43.1	38	1.8	32.49						43.1	53			1.3	32.49		B5/B14		
	33.3	50	1.4	42.04						33.3	69			1.0	42.04		B5/B14		
	31.2	53	1.3	44.89						31.2	73			1.0	44.89		B5/B14		
	28.7	58	1.2	48.86						28.7	80			0.9	48.86		B5/B14		
	25.4	65	1.1	55.10				25.4	90	0.8	55.10		B5/B14						
	78.4	21	5.7	17.86	CMG012	B5		367	6	9.6	3.82	CMG012	B5/B14						
	73.4	22	5.3	19.07						302	8			7.9	4.63		B5/B14		
	70.6	23	5.1	19.83						246	9			6.4	5.69		B5/B14		
	59.4	28	4.3	23.56						181	13			6.3	7.72		B5/B14		
	47.4	35	3.4	29.56						153	15			5.3	9.17		B5/B14		
	39.5	42	2.9	35.47						143	16			5.0	9.81		B5/B14		
	30.5	54	2.2	45.89						122	19			5.3	11.50		B5/B14		
	28.6	58	2.1	49.00						118	19			5.1	11.90		B5/B14		
	26.3	63	1.9	53.33						101	23			5.3	13.80		B5/B14		
	23.3	71	1.7	60.15						95.7	24			5.0	14.62		B5/B14		
	22.1	73	1.6	63.22	CMG013	B5		78.4	29	4.1	17.86		B5/B14						
	18.6	87	1.4	75.08						73.4	31	3.8	19.07		B5/B14				
	15.7	103	1.2	89.17						70.6	32	3.7	19.83		B5/B14				
	12.4	130	0.9	113.05						59.4	39	3.1	23.56		B5/B14				
	23.0	72	2.8	60.90	CMG022	B5		47.4	48	2.5	29.56		B5/B14						
	21.9	74	2.7	64.01						39.5	58	2.1	35.47		B5/B14				
	18.4	88	2.3	76.02	CMG023	B5		30.5	75	1.6	45.89		B5/B14						
	15.5	104	1.9	90.29						28.6	80	1.5	49.00		B5/B14				
	12.2	132	1.5	114.46						26.3	87	1.4	53.33		B5/B14				
	10.3	157	1.3	135.95	CMG013	B5		23.3	98	1.2	60.15		B5/B14						
	8.0	203	1.0	175.89						22.1	101	1.2	63.22		B5/B14				
	6.8	236	0.8	204.69						18.6	120	1.0	75.08		B5/B14				
	19.2	84	3.6	72.83	CMG033	B5		15.7	143	0.8	89.17		B5/B14						
	14.4	112	2.7	97.45						383	6	16.7	3.66	CMG022	B5/B14				
	12.1	134	2.2	115.74						316	7	13.8	4.43				B5/B14		
	9.9	163	1.8	140.81						257	9	11.2	5.45				B5/B14		
	8.0	201	1.5	174.26						189	12	9.9	7.39				B5/B14		
	6.2	260	1.2	225.47						160	14	8.4	8.78				B5/B14		
	5.3	302	1.0	262.05						141	16	7.4	9.93				B5/B14		
	19.2	84	5.9	72.83			CMG043	B5		127	18	11.1	11.01				B5/B14		
	14.4	112	4.4	97.45								116	20			10.1	12.05		B5/B14
	12.1	134	3.7	115.74								106	22			9.2	13.21		B5/B14
	9.9	163	3.1	140.81						106	22	9.2	13.21				B5/B14		
	8.0	201	2.5	174.26						94.6	24	8.3	14.81		B5/B14				
	6.2	260	1.9	225.47						81.9	28	5.7	17.10		B5/B14				
	5.3	302	1.7	262.05						76.7	30	5.4	18.26		B5/B14				
	4.3	376	1.3	325.79						69.7	33	6.1	20.08		B5/B14				
	3.7	437	1.1	378.64						58.7	39	5.1	23.85		B5/B14				
	3.3	493	1.0	427.03						46.8	49	4.1	29.93		B5/B14				
										39.0	59	3.4	35.91		B5/B14				
										30.1	76	2.6	46.46		B5/B14				
								28.2	81	2.5	49.61		B5/B14						
								25.9	88	2.3	54.00		B5/B14						
								23.0	100	2.0	60.90		B5/B14						

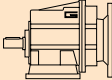

Dati tecnici

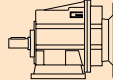
Technical data

P ₁ [kW]	n ₂ [min ⁻¹]	M ₂ [Nm]	sf	i			P ₁ [kW]	n ₂ [min ⁻¹]	M ₂ [Nm]	sf	i			
0.25							0.37							
71A4 (1400 min ⁻¹)	21.9	103	1.9	64.01	CMG023	B5/B14	71B4 (1400 min ⁻¹)	22.1	150	0.8	63.22	CMG013	B5/B14	
	18.4	122	1.6	76.02		B5/B14		383	9	11.3	3.66		CMG022	B5/B14
	15.5	145	1.4	90.29		B5/B14		316	11	9.3	4.43		B5/B14	
	12.2	183	1.1	114.46		B5/B14		257	13	7.6	5.45		B5/B14	
	10.3	218	0.9	135.95		B5/B14		189	18	6.7	7.39		B5/B14	
	31.7	72	4.1	44.18	CMG032	B5		160	21	5.6	8.78	B5/B14		
	27.3	84	3.6	51.30		B5		141	24	5.0	9.93	B5/B14		
	19.2	117	2.6	72.83	CMG033	B5/B14		127	27	7.5	11.01	B5/B14		
	14.4	156	1.9	97.45		B5/B14		116	29	6.8	12.05	B5/B14		
	12.1	186	1.6	115.74		B5/B14		106	32	6.2	13.21	B5/B14		
	9.9	226	1.3	140.81		B5/B14		94.6	36	5.6	14.81	B5/B14		
	8.0	279	1.1	174.26		B5/B14		81.9	41	3.9	17.10	B5/B14		
	6.2	361	0.8	225.47	B5/B14		76.7	44	3.6	18.26	B5/B14			
	19.2	117	4.3	72.83	CMG043	B5/B14		69.7	49	4.1	20.08	B5/B14		
	14.4	156	3.2	97.45		B5/B14		58.7	58	3.5	23.85	B5/B14		
	12.1	186	2.7	115.74		B5/B14		46.8	73	2.8	29.93	B5/B14		
	9.9	226	2.2	140.81		B5/B14		39.0	87	2.3	35.91	B5/B14		
	8.0	279	1.8	174.26		B5/B14		30.1	113	1.8	46.46	B5/B14		
	6.2	361	1.4	225.47		B5/B14		28.2	120	1.7	49.61	B5/B14		
	5.3	420	1.2	262.05		B5/B14		25.9	131	1.5	54.00	B5/B14		
	4.3	522	1.0	325.79		B5/B14		23.0	148	1.4	60.90	B5/B14		
	3.7	607	0.8	378.64		B5/B14		21.9	152	1.3	64.01	CMG023	B5/B14	
								18.4	180	1.1	76.02		B5/B14	
								15.5	214	0.9	90.29		B5/B14	
0.37														
71B4 (1400 min ⁻¹)	279	12	3.3	5.03	CMG002	B5/B14		374	9	16.5	3.74	CMG032	B5	
	230	15	2.7	6.10		B5/B14		311	11	13.7	4.50		B5	
	187	18	2.2	7.49		B5/B14		255	13	11.3	5.48		B5	
	156	22	2.3	8.99		B5/B14		222	15	11.8	6.31		B5	
	138	25	2.0	10.16		B5/B14		177	19	9.4	7.93		B5	
	116	29	1.7	12.07		B5/B14		154	22	8.2	9.08		B5	
	105	32	2.2	13.40		B5/B14		128	26	6.8	10.93		B5	
	92.5	37	1.9	15.14		B5/B14		111	31	8.2	12.60		B5	
	77.1	44	1.6	18.17		B5/B14		105	32	7.8	13.30		B5	
	64.9	52	1.3	21.58		B5/B14		91.5	37	7.6	15.30		B5	
	59.6	57	1.2	23.51		B5/B14		76.9	44	6.3	18.21		B5	
	55.8	61	1.2	25.10		B5/B14		72.8	47	6.0	19.24		B5	
	51.7	66	1.1	27.08		B5/B14		66.2	51	5.5	21.15		B5	
	43.1	79	0.9	32.49		B5/B14		56.0	61	5.0	24.99		B5	
	367	9	6.5	3.82		CMG012	B5/B14		45.8	74	4.0		30.57	B5
	302	11	5.3	4.63			B5/B14		40.9	83	3.6		34.20	B5
	246	14	4.4	5.69			B5/B14		36.2	94	3.2		38.63	B5
	181	19	4.3	7.72	B5/B14			31.7	107	2.8	44.18	B5		
	153	22	3.6	9.17	B5/B14			27.3	124	2.4	51.30	B5		
	143	24	3.4	9.81	B5/B14			23.0	147	2.0	60.80	B5		
	122	28	3.6	11.50	B5/B14			19.2	173	1.7	72.83	CMG033	B5/B14	
	118	29	3.5	11.90	B5/B14			14.4	231	1.3	97.45		B5/B14	
	101	33	3.6	13.80	B5/B14			12.1	275	1.1	115.74		B5/B14	
	95.7	35	3.4	14.62	B5/B14			9.9	334	0.9	140.81	B5/B14		
	78.4	43	2.8	17.86	B5/B14			19.2	173	2.9	72.83	CMG043	B5/B14	
	73.4	46	2.6	19.07	B5/B14			14.4	231	2.2	97.45		B5/B14	
	70.6	48	2.5	19.83	B5/B14			12.1	275	1.8	115.74		B5/B14	
	59.4	57	2.1	23.56	B5/B14			9.9	334	1.5	140.81		B5/B14	
	47.4	72	1.7	29.56	B5/B14			8.0	413	1.2	174.26		B5/B14	
	39.5	86	1.4	35.47	B5/B14			6.2	535	0.9	225.47		B5/B14	
	30.5	111	1.1	45.89	B5/B14									
	28.6	119	1.0	49.00	B5/B14									
	26.3	129	0.9	53.33	B5/B14									
	23.3	146	0.8	60.15	B5/B14									

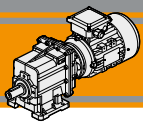





CMG

Motoriduttori ad ingranaggi cilindrici
Helical in-line gearmotors

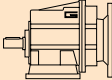
Dati tecnici

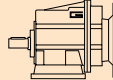

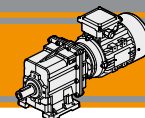

Technical data

P ₁ [kW]	n ₂ [min ⁻¹]	M ₂ [Nm]	sf	i			P ₁ [kW]	n ₂ [min ⁻¹]	M ₂ [Nm]	sf	i			
0.55							0.55							
80A4 (1400 min ⁻¹)	279	18	2.2	5.03	CMG002	B5/B14	80A4 (1400 min ⁻¹)	72.8	69	4.0	19.24	CMG032	B5/B14	
	230	22	1.8	6.10			B5/B14	66.2	76	3.7	21.15			B5/B14
	187	27	1.5	7.49			B5/B14	56.0	90	3.3	24.99			B5/B14
	156	32	1.5	8.99			B5/B14	45.8	110	2.7	30.57			B5/B14
	138	37	1.4	10.16			B5/B14	40.9	123	2.4	34.20			B5/B14
	116	43	1.2	12.07			B5/B14	36.2	139	2.2	38.63			B5/B14
	105	48	1.5	13.40			B5/B14	31.7	159	1.9	44.18			B5/B14
	92.5	55	1.3	15.14			B5/B14	27.3	185	1.6	51.30			B5/B14
	77.1	65	1.1	18.17			B5/B14	23.0	219	1.4	60.80			B5/B14
	64.9	78	0.9	21.58			B5/B14	19.2	257	1.2	72.83			CMG033
	59.6	85	0.8	23.51	B5/B14	14.4	344	0.9	97.45	B5/B14				
	23.0	219	0.9	60.90	B5/B14	23.0	219	2.2	60.80	CMG042	B5/B14			
	367	14	4.4	3.82	CMG012	B5/B14	19.2	257	1.9	72.83	CMG043	B5/B14		
	302	17	3.6	4.63			B5/B14	14.4	344	1.5			97.45	B5/B14
	246	20	2.9	5.69			B5/B14	12.1	408	1.2			115.74	B5/B14
	181	28	2.9	7.72			B5/B14	9.9	497	1.0			140.81	B5/B14
	153	33	2.4	9.17			B5/B14	9.9	497	1.0			140.81	B5/B14
	143	35	2.3	9.81			B5/B14	8.0	615	0.8			174.26	B5/B14
	122	41	2.4	11.50			B5/B14							
	118	43	2.3	11.90			B5/B14							
	101	50	2.4	13.80			B5/B14							
	95.7	53	2.3	14.62			B5/B14							
	78.4	64	1.9	17.86	B5/B14									
	73.4	69	1.7	19.07	B5/B14									
	70.6	71	1.7	19.83	B5/B14									
	59.4	85	1.4	23.56	B5/B14									
	47.4	106	1.1	29.56	B5/B14									
	39.5	128	0.9	35.47	B5/B14									
	383	13	7.6	3.66	CMG022	B5/B14	279	25	1.6	5.03	CMG002	B5/B14		
	316	16	6.3	4.43			B5/B14	230	30	1.3			6.10	B5/B14
	257	20	5.1	5.45			B5/B14	187	37	1.1			7.49	B5/B14
	189	27	4.5	7.39			B5/B14	156	44	1.1			8.99	B5/B14
	160	32	3.8	8.78			B5/B14	138	50	1.0			10.16	B5/B14
	141	36	3.4	9.93			B5/B14	116	59	0.8			12.07	B5/B14
	127	40	5.0	11.01			B5/B14	105	66	1.1			13.40	B5/B14
	116	43	4.6	12.05			B5/B14	92.5	74	0.9			15.14	B5/B14
	106	48	4.2	13.21			B5/B14	77.1	89	0.8			18.17	B5/B14
	94.6	53	3.8	14.81			B5/B14	367	19	3.2			3.82	CMG012
	81.9	62	2.6	17.10	B5/B14	302	23	2.6	4.63	B5/B14				
	76.7	66	2.4	18.26	B5/B14	246	28	2.1	5.69	B5/B14				
	69.7	72	2.8	20.08	B5/B14	181	38	2.1	7.72	B5/B14				
	58.7	86	2.3	23.85	B5/B14	153	45	1.8	9.17	B5/B14				
	46.8	108	1.9	29.93	B5/B14	143	48	1.7	9.81	B5/B14				
	39.0	129	1.5	35.91	B5/B14	122	56	1.8	11.50	B5/B14				
	30.1	167	1.2	46.46	B5/B14	118	58	1.7	11.90	B5/B14				
	28.2	179	1.1	49.61	B5/B14	101	68	1.8	13.80	B5/B14				
	25.9	194	1.0	54.00	B5/B14	95.7	72	1.7	14.62	B5/B14				
	23.0	219	0.9	60.90	B5/B14	78.4	88	1.4	17.86	B5/B14				
	21.9	226	0.9	64.01	CMG023	73.4	94	1.3	19.07	B5/B14				
	374	13	11.1	3.74	CMG032	B5/B14	70.6	97	1.2	19.83	B5/B14			
	311	16	9.2	4.50			B5/B14	59.4	116	1.0	23.56	B5/B14		
	255	20	7.6	5.48			B5/B14	383	18	5.6	3.66	CMG022	B5/B14	
	222	23	7.9	6.31			B5/B14	316	22	4.6	4.43			B5/B14
	177	29	6.3	7.93			B5/B14	257	27	3.7	5.45			B5/B14
	154	33	5.5	9.08			B5/B14	189	36	3.3	7.39			B5/B14
	128	39	4.6	10.93			B5/B14	160	43	2.8	8.78			B5/B14
	111	45	5.5	12.60			B5/B14	141	49	2.5	9.93			B5/B14
	105	48	5.2	13.30			B5/B14	127	54	3.7	11.01			B5/B14
	91.5	55	5.1	15.30			B5/B14	116	59	3.4	12.05			B5/B14
	76.9	66	4.3	18.21	B5/B14	106	65	3.1	13.21	B5/B14				
					B5/B14	94.6	73	2.8	14.81	B5/B14				
					B5/B14	81.9	84	1.9	17.10	B5/B14				
					B5/B14	76.7	90	1.8	18.26	B5/B14				
					B5/B14	69.7	99	2.0	20.08	B5/B14				
					B5/B14	58.7	117	1.7	23.85	B5/B14				
					B5/B14	46.8	147	1.4	29.93	B5/B14				
					B5/B14	39.0	176	1.1	35.91	B5/B14				

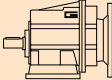

Dati tecnici

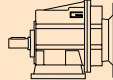
Technical data

P ₁ [kW]	n ₂ [min ⁻¹]	M ₂ [Nm]	sf	i			P ₁ [kW]	n ₂ [min ⁻¹]	M ₂ [Nm]	sf	i					
0.75							1.1									
80B4 (1400 min ⁻¹)	30.1	228	0.9	46.46	CMG022	B5/B14	90S4	383	26	3.8	3.66	CMG022	B5/B14			
	28.2	244	0.8	49.61			316	32	3.1	4.43	B5/B14					
	25.9	265	0.8	54.00			257	39	2.5	5.45	B5/B14					
	374	18	8.2	3.74	CMG032	B5/B14	189	53	2.3	7.39	B5/B14	CMG032	B5/B14			
	311	22	6.8	4.50			160	63	1.9	8.78	B5/B14					
	255	27	5.6	5.48			141	72	1.7	9.93	B5/B14					
	222	31	5.8	6.31			127	79	2.5	11.01	B5/B14					
	177	39	4.6	7.93			116	87	2.3	12.05	B5/B14					
	154	45	4.0	9.08			106	95	2.1	13.21	B5/B14					
	128	54	3.4	10.93			94.6	107	1.9	14.81	B5/B14					
	111	62	4.0	12.60			81.9	123	1.3	17.10	B5/B14					
	105	65	3.8	13.30			76.7	132	1.2	18.26	B5/B14					
	91.5	75	3.7	15.30			69.7	145	1.4	20.08	B5/B14					
	76.9	89	3.1	18.21			58.7	172	1.2	23.85	B5/B14					
	72.8	94	3.0	19.24			46.8	216	0.9	29.93	B5/B14					
	66.2	104	2.7	21.15			39.0	259	0.8	35.91	B5/B14					
	56.0	123	2.4	24.99												
	45.8	150	2.0	30.57					374	27	5.6			3.74	CMG032	B5/B14
	40.9	168	1.8	34.20			311	32	4.6	4.50	B5/B14					
	36.2	190	1.6	38.63			255	39	3.8	5.48	B5/B14					
	31.7	217	1.4	44.18			222	45	4.0	6.31	B5/B14					
	27.3	252	1.2	51.30			177	57	3.2	7.93	B5/B14					
	23.0	299	1.0	60.80			154	65	2.8	9.08	B5/B14					
							128	79	2.3	10.93	B5/B14					
							111	91	2.8	12.60	B5/B14					
	374	18	12.5	3.74	CMG042	B5/B14	105	96	2.6	13.30	B5/B14	CMG042	B5/B14			
	311	22	10.4	4.50			91.5	110	2.5	15.30	B5/B14					
	255	27	8.5	5.48			76.9	131	2.1	18.21	B5/B14					
	222	31	8.4	6.31			72.8	139	2.0	19.24	B5/B14					
	177	39	6.7	7.93			66.2	152	1.8	21.15	B5/B14					
	154	45	6.3	9.08			56.0	180	1.7	24.99	B5/B14					
	128	54	5.2	10.93			45.8	220	1.4	30.57	B5/B14					
	111	62	5.7	12.60			40.9	246	1.2	34.20	B5/B14					
	105	65	5.4	13.30			36.2	278	1.1	38.63	B5/B14					
	91.5	75	5.6	15.30			31.7	318	0.9	44.18	B5/B14					
	76.9	89	4.7	18.21												
	72.8	94	4.4	19.24					374	27	8.5			3.74	CMG042	B5/B14
	56.0	123	4.1	24.99					311	32	7.1			4.50	B5/B14	
	45.8	150	3.3	30.57					255	39	5.8			5.48	B5/B14	
	40.9	168	3.0	34.20					222	45	5.7			6.31	B5/B14	
	36.2	190	2.6	38.63			177	57	4.6	7.93	B5/B14					
	31.7	217	2.3	44.18			154	65	4.3	9.08	B5/B14					
	27.3	252	2.0	51.30			128	79	3.6	10.93	B5/B14					
	23.0	299	1.6	60.80			111	91	3.9	12.60	B5/B14					
							105	96	3.7	13.30	B5/B14					
	19.2	350	1.4	72.83	CMG043	B5/B14	91.5	110	3.8	15.30	B5/B14	CMG043	B5/B14			
	14.4	469	1.1	97.45			76.9	131	3.2	18.21	B5/B14					
	12.1	557	0.9	115.74			72.8	139	3.0	19.24	B5/B14					
							56.0	180	2.8	24.99	B5/B14					
							45.8	220	2.3	30.57	B5/B14					
							40.8	247	2.0	34.30	B5/B14					
							36.2	278	1.8	38.63	B5/B14					
							31.7	318	1.6	44.18	B5/B14					
							27.3	370	1.4	51.30	B5/B14					
							23.0	438	1.1	60.80	B5/B14					
							19.2	514	1.0	72.83	CMG043	B5/B14				
1.1							1.5									
90S4 (1400 min ⁻¹)	367	28	2.2	3.82	CMG012	B5/B14	90L4	367	38	1.6	3.82	CMG012	B5/B14			
	302	33	1.8	4.63			302	45	1.3	4.63	B5/B14					
	246	41	1.5	5.69			246	56	1.1	5.69	B5/B14					
	181	56	1.4	7.72			181	76	1.1	7.72	B5/B14					
	153	66	1.2	9.17			153	90	0.9	9.17	B5/B14					
	143	71	1.1	9.81												
	122	83	1.2	11.50												
	118	86	1.2	11.90												
	101	99	1.2	13.80												
	95.7	105	1.1	14.62												
	78	129	0.9	17.86												

CMG

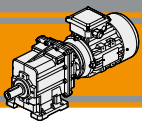
**CMG**

Motoriduttori ad ingranaggi cilindrici
Helical in-line gearmotors

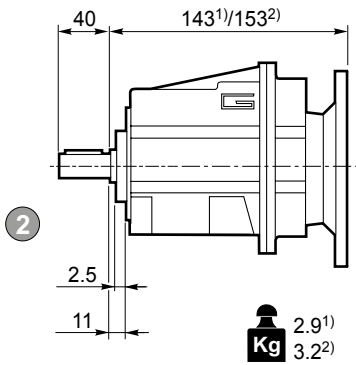
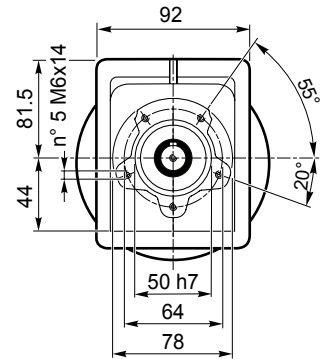
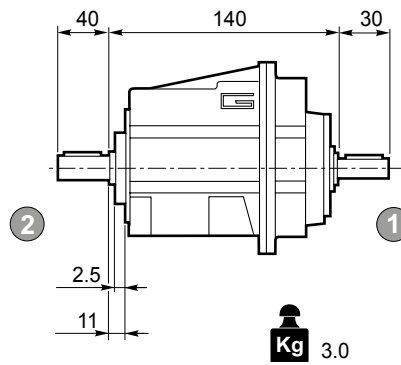
Dimensioni**Dimensions****CMG 002 U****CMG 002 U****CMGIS 002 U**¹IEC 63/71, ²IEC 80

Flangia entrata
Input flange

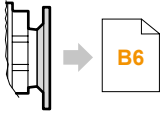

Albero uscita
Output shaft

2

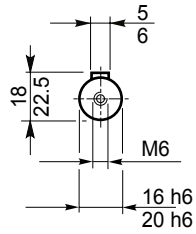

Albero entrata
Input shaft

1

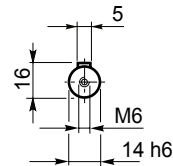

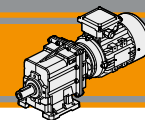

Dimensioni

Dimensions

CMG 002 H..

CMG 002 H..

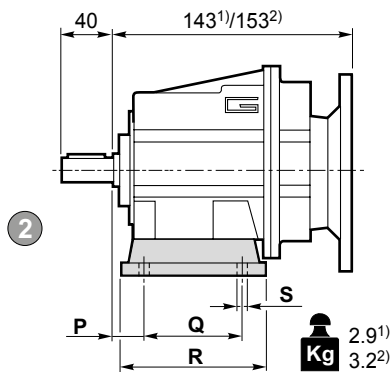

CMGIS 002 H..

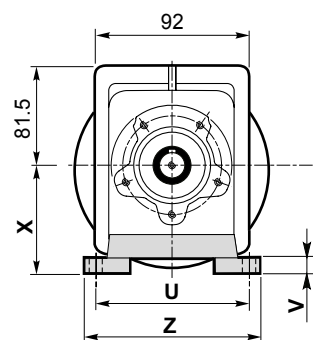
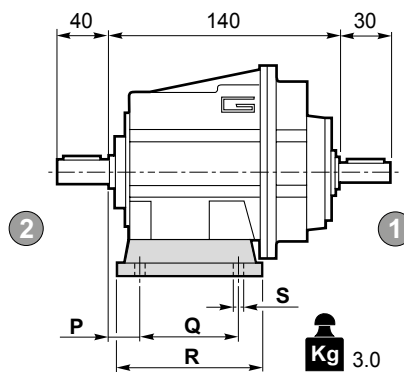

¹⁾IEC 63/71, ²⁾IEC 80

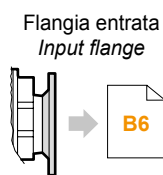

Albero uscita
Output shaft

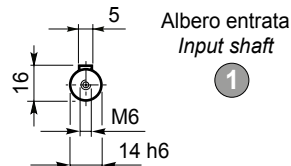
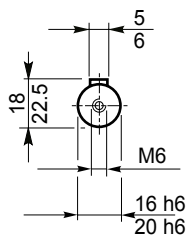

Versione H / H Version										
CMG CMGIS	P	Q	R	S	U	V	X	Z	Piede / Foot	
									Tipo / Type	Peso / Weight [kg]
002	18	60	80	9	100	10	60	120	H60	0.2
	18	80	104	9	110 - 120	10	75	145	H75	0.3
	18	50 - 87	110	9	110	10	85	135	H85	0.4

Preferenziale / Preferred

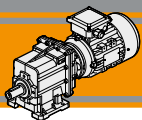

CMG 002 F..

CMG 002 F..

CMGIS 002 F..

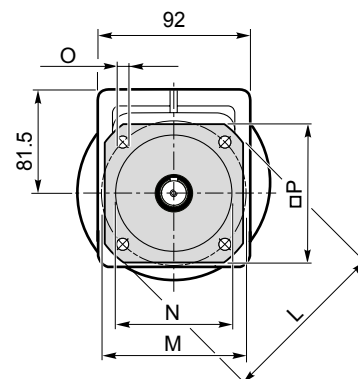
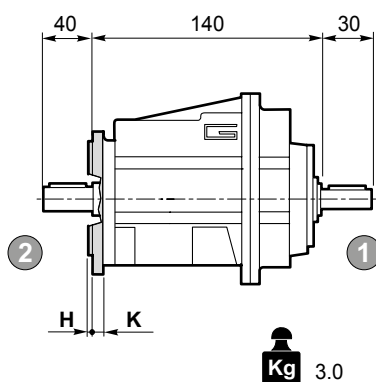
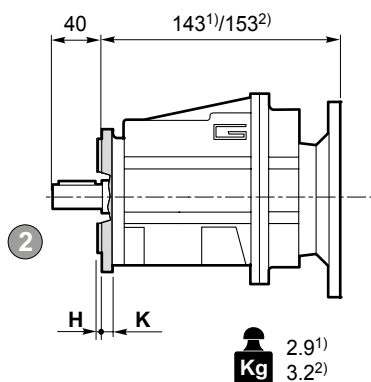

¹⁾IEC 63/71, ²⁾IEC 80

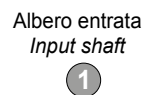
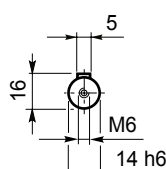
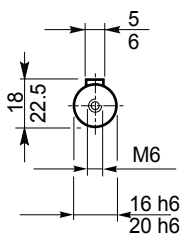
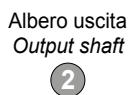
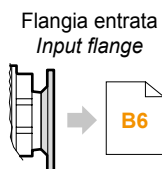

Versione F / F Version									
CMG CMGIS	H	K	L	M	N f7	O	P	Flangia / Flange	
								Tipo / Type	Peso / Weight [kg]
002	3.5	7	105	85	70	6.5	90	F105	0.1
	3.5	8	120	100	80	7	100	F120	0.2
	3.5	8	140	115	95	9	115	F140	0.2

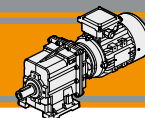

Dimensioni

Dimensions

CMG 002 H../F..

CMG 002 H../F..

CMGIS 002 H../F..

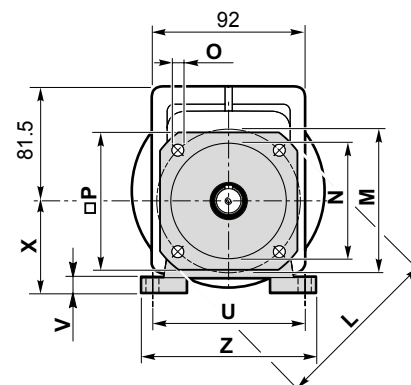
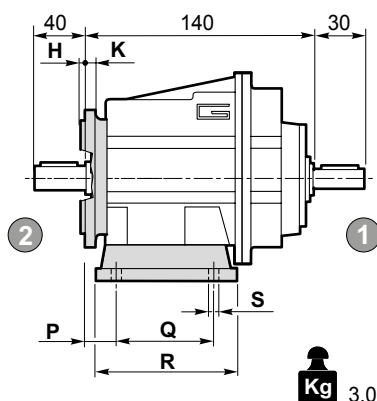
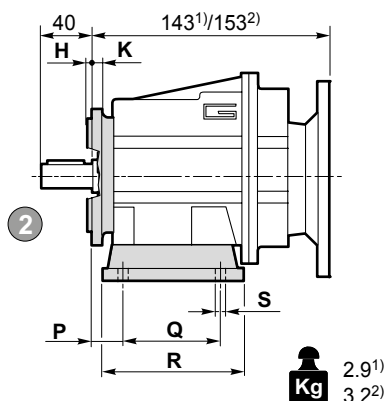

¹)IEC 63/71, ²)IEC 80

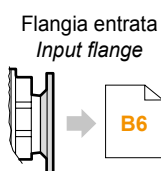

Albero uscita
Output shaft

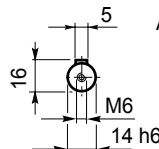
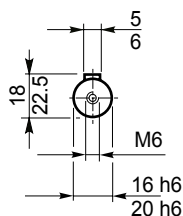

Albero entrata
Input shaft



CMG CMGIS	Versione H / H Version									Combinazioni possibili H/F Possible combinations H/F			
	P	Q	R	S	U	V	X	Z	Piede / Foot		F105	F120	F140
									Tipo Type	Peso / Weight [kg]			
002	18	60	80	9	100	10	60	120	H60	0.2	•	•	•
	18	80	104	9	110 - 120	10	75	145	H75	0.3	•	•	•
	18	50 - 87	110	9	110	10	85	135	H85	0.4	•	•	•

Preferenziale / Preferred

• Combinazioni possibili H/F / Possible combinations H/F

CMG CMGIS	Versione F / F Version								Flangia / Flange	
	H	K	L	M	N f7	O	P	Flangia / Flange		
								Tipo / Type	Peso / Weight [kg]	
002	3.5	7	105	85	70	6.5	90	F105	0.1	
	3.5	8	120	100	80	7	100	F120	0.2	
	3.5	8	140	115	95	9	115	F140	0.2	

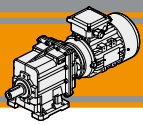

**CMG**

Motoriduttori ad ingranaggi cilindrici
Helical in-line gearmotors

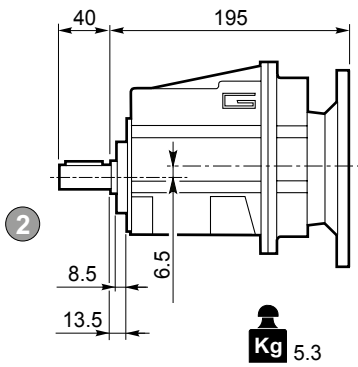
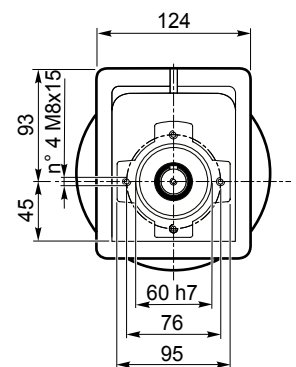
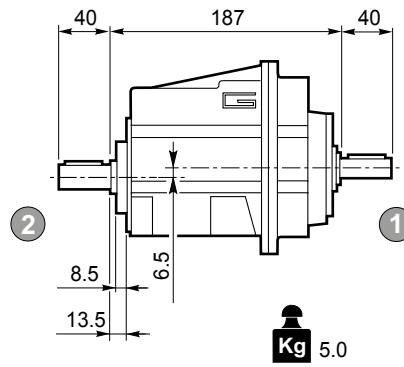
Dimensioni**Dimensions****CMG 012 U - CMG 013 U****CMG 012 U****CMGIS 012 U**

Flangia entrata
Input flange

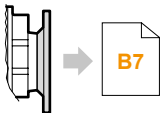

Albero uscita
Output shaft

2

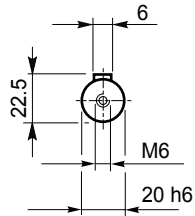

Albero entrata
Input shaft

1

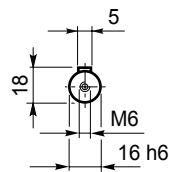
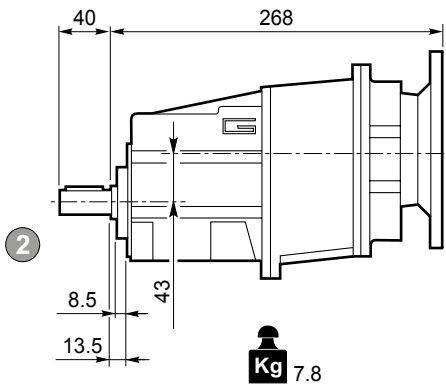
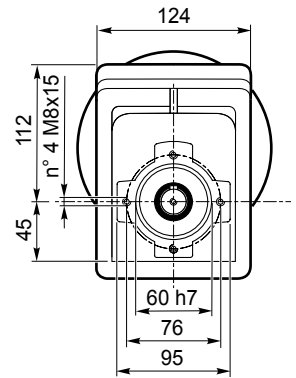
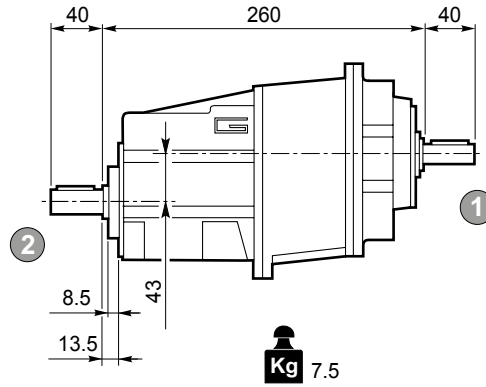
**CMG 013 U****CMGIS 013 U**

Flangia entrata
Input flange

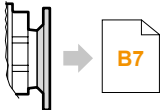

Albero uscita
Output shaft

2

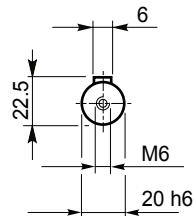

Albero entrata
Input shaft

1

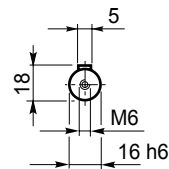

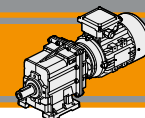

Dimensioni

Dimensions

CMG 012 H.. - CMG 013 H..

CMG 012 H..

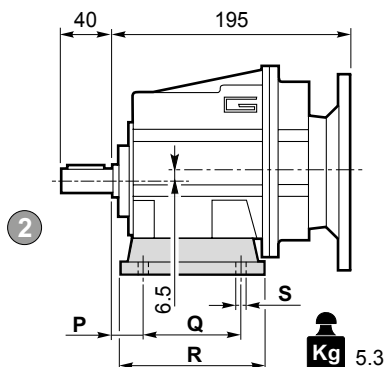

CMGIS 012 H..

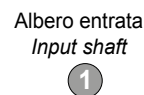
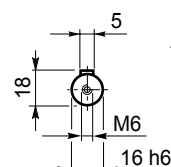
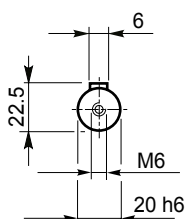
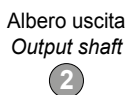
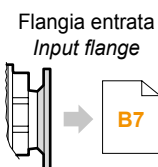
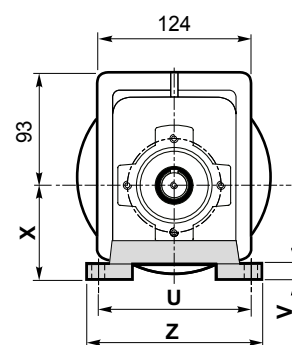
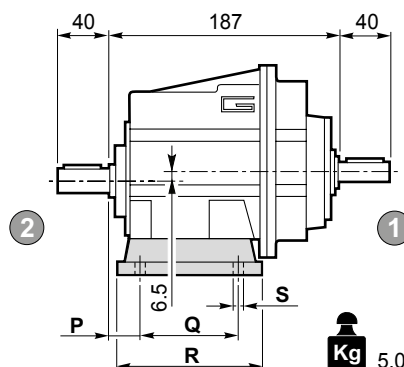

CMG 013 H..

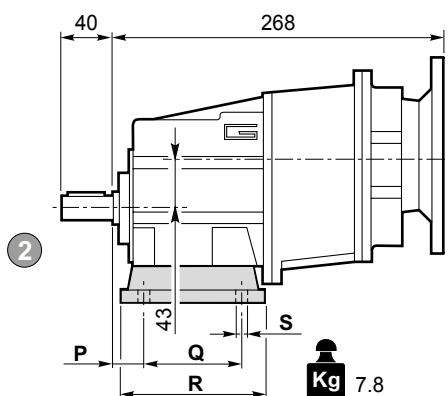

CMGIS 013 H..

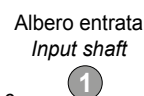
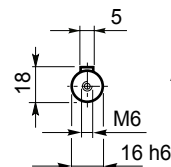
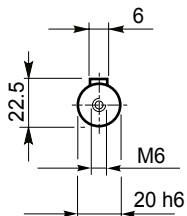
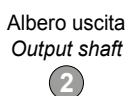
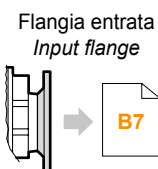
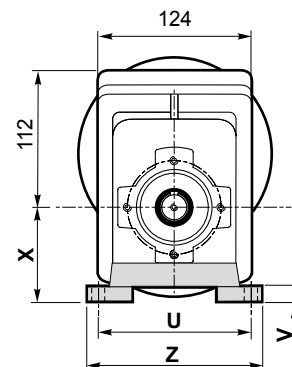
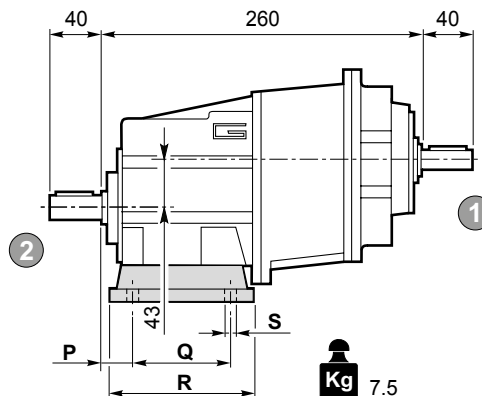

Versione H / H Version

CMG CMGIS	P	Q	R	S	U	V	X	Z	Piede / Foot	
									Tipo / Type	Peso / Weight [kg]
012 013	20	85	108	9	115	12	65	139	H65	0.7
	18	80	118	9	110	12	75	140	H75	1.0
	25	85	120	9	120	12	80	140	H80	1.1
	18	50 - 87	118	9	110	12	85	130	H85	1.2
	25	130	154	9	110	12	90	135	H90	1.5
	18	60 - 107.5	135	11	130	12	100	155	H100	1.7

Preferenziale / Preferred

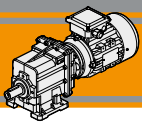

CMG

Motoriduttori ad ingranaggi cilindrici
Helical in-line gearmotors

Dimensioni

Dimensions

CMG 012 F.. - CMG 013 F..

CMG 012 F..

CMGIS 012 F..

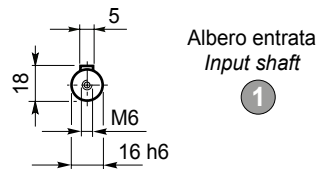
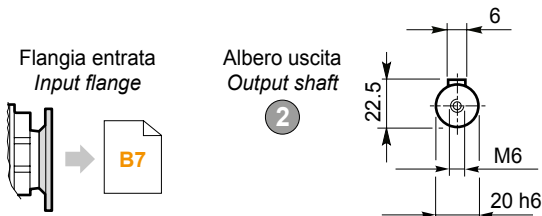
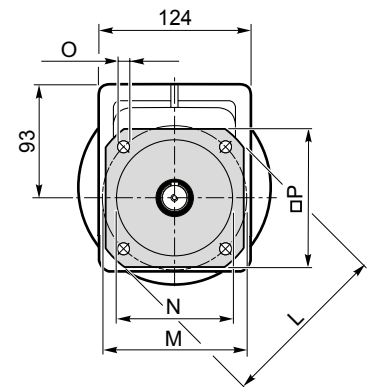
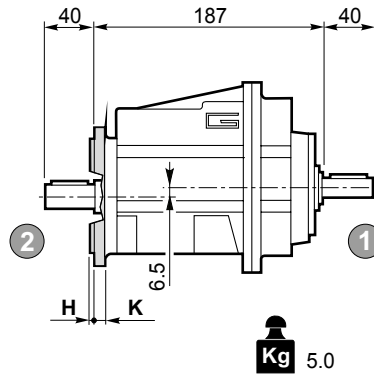
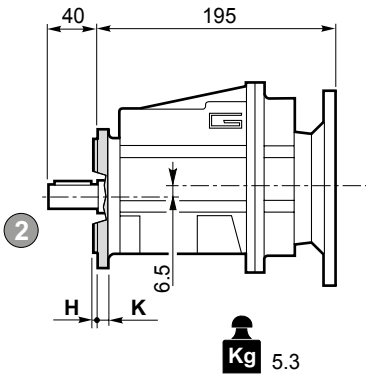

CMG 013 F..

CMGIS 013 F..

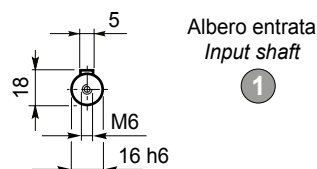
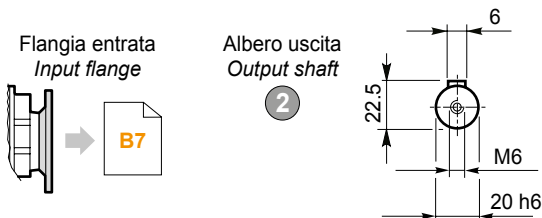
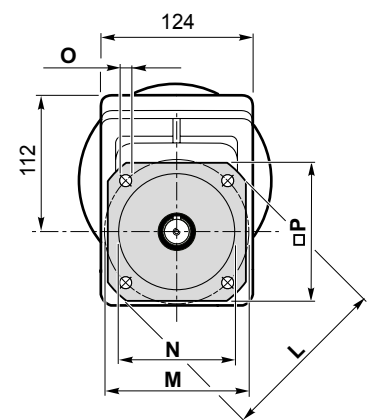
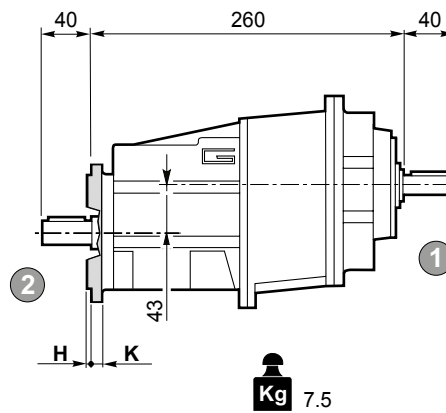
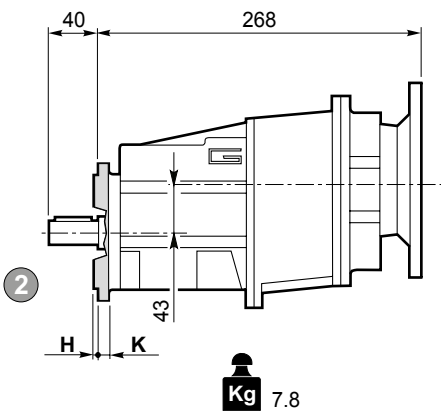

Versione F / F Version									
CMG CMGIS	H	K	L	M	N f7	O	P	Flangia / Flange	
								Tipo / Type	Peso / Weight [kg]
012 013	3	9	120	100	80	9	106	F120	0.5
	3.5	9	140	115	95	9	115	F140	0.8
	3.5	9	160	130	110	9	126	F160	1.1
	3.5	11	200	165	130	11	165	F200	1.8

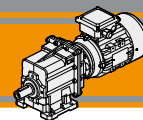

Dimensioni

Dimensions

CMG 012 H../F.. - CMG 013 H../F..

CMG 012 H../F..

CMGIS 012 H../F..

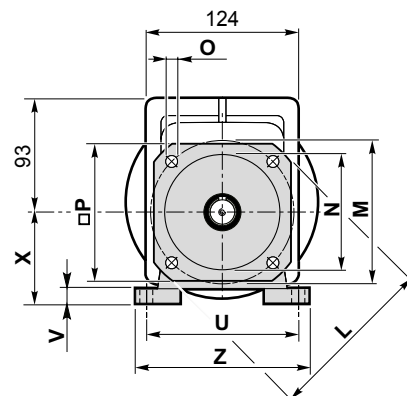
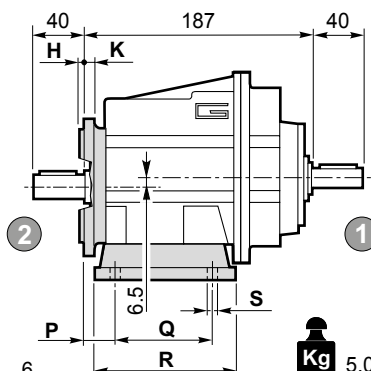
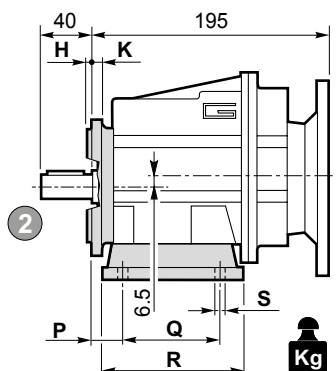

Kg 5.3

Kg 5.0

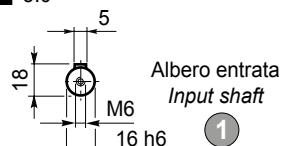
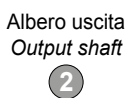
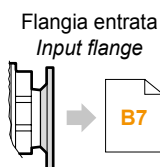

CMG 013 H../F..

CMGIS 013 H../F..

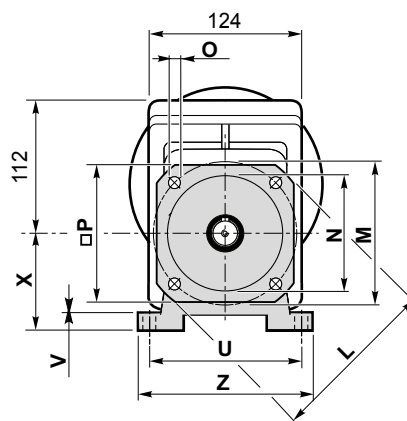
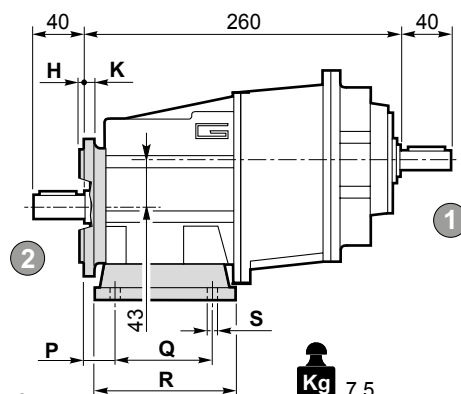
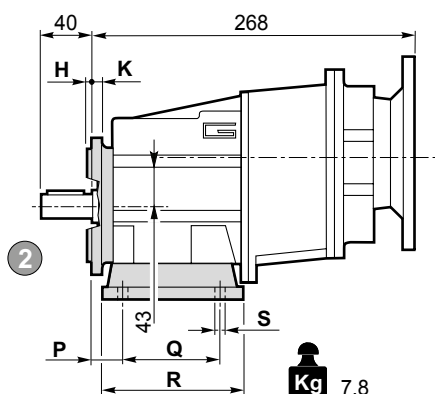

Kg 7.8

Kg 7.5

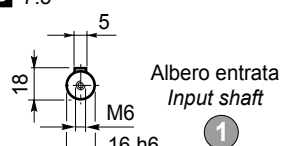
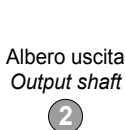
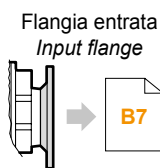

CMG CMGIS	Versione H / H Version								Piede / Foot		Combinazioni possibili H/F Possible combinations H/F			
	P	Q	R	S	U	V	X	Z	Tipo Type	Peso / Weight [kg]	F120	F140	F160	F200
	012 013	20	85	108	9	115	12	65	139	H65	0.7	•	•	
18		80	118	9	110	12	75	140	H75	1.0	•	•	•	
25		85	120	9	120	12	80	140	H80	1.1	•	•	•	
18		50 - 87	118	9	110	12	85	130	H85	1.2	•	•	•	
25		130	154	9	110	12	90	135	H90	1.5	•	•	•	•
18		60 - 107.5	135	11	130	12	100	155	H100	1.7	•	•	•	•

Preferenziale / Preferred

• Combinazioni possibili H/F / Possible combinations H/F

CMG CMGIS	Versione F / F Version							Flangia / Flange	
	H	K	L	M	N f7	O	P	Tipo / Type	Peso / Weight [kg]
	012 013	3	9	120	100	80	9	106	F120
3.5		9	140	115	95	9	115	F140	0.8
3.5		9	160	130	110	9	126	F160	1.1
3.5		11	200	165	130	11	165	F200	1.8

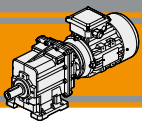

**CMG**

Motoriduttori ad ingranaggi cilindrici
Helical in-line gearmotors

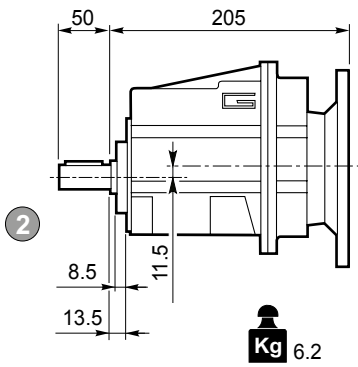
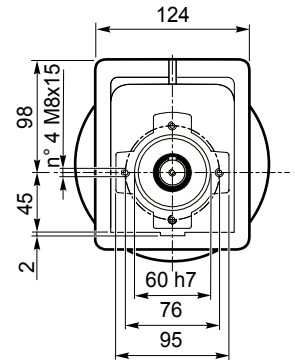
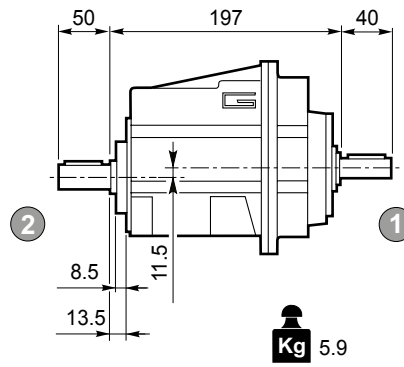
Dimensioni**Dimensions****CMG 022 U - CMG 023 U****CMG 022 U****CMGIS 022 U**

Flangia entrata
Input flange

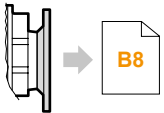

Albero uscita
Output shaft

2

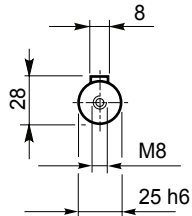

Albero entrata
Input shaft

1

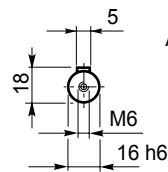
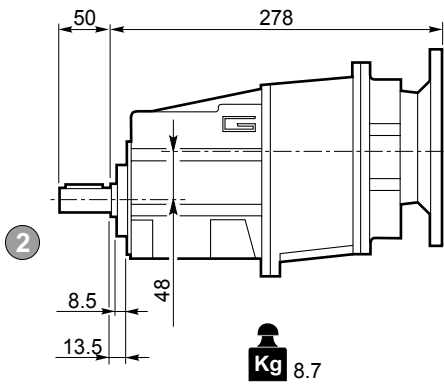
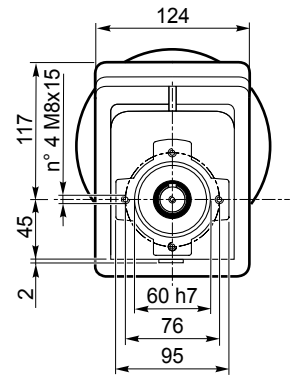
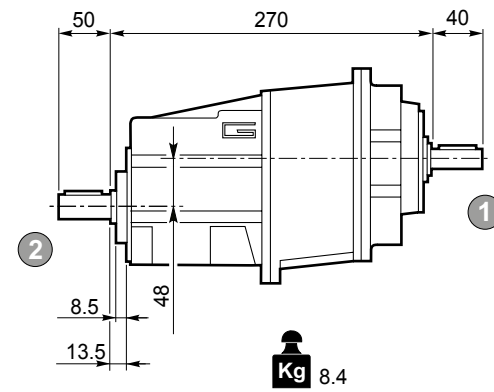
**CMG 023 U****CMGIS 023 U**

Flangia entrata
Input flange

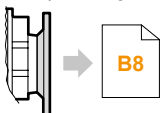

Albero uscita
Output shaft

2

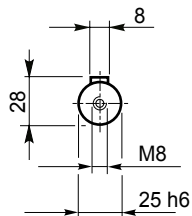

Albero entrata
Input shaft

1

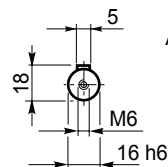

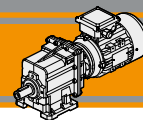

Dimensioni

Dimensions

CMG 022 H.. - CMG 023 H..

CMG 022 H..

CMGIS 022 H..

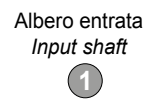
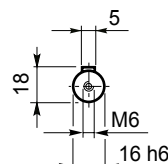
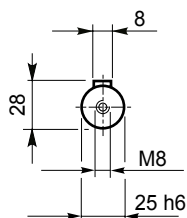
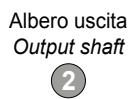
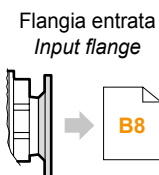
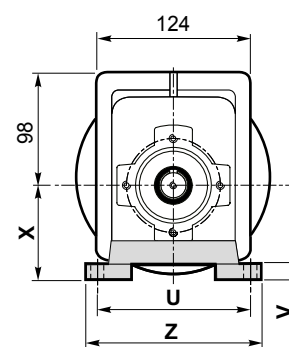
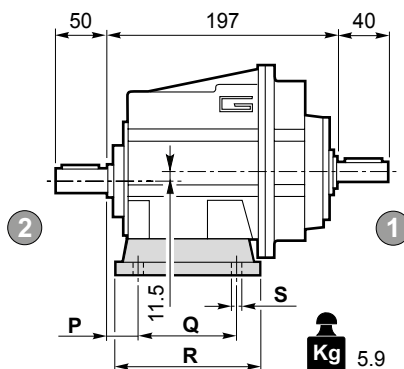
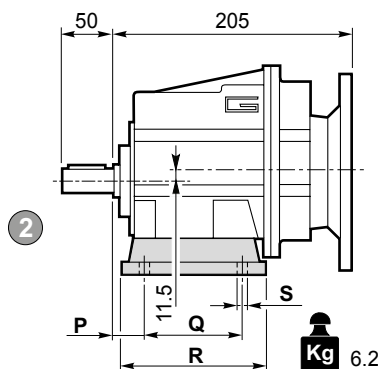

CMG 023 H..

CMGIS 023 H..

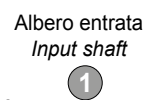
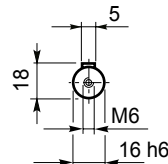
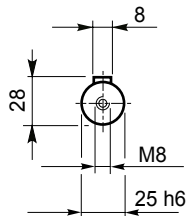
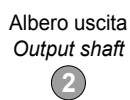
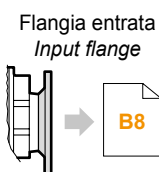
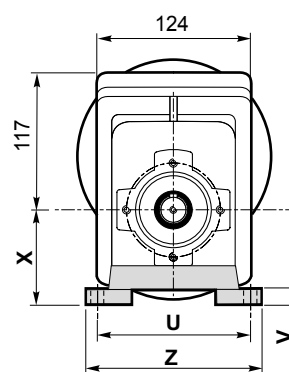
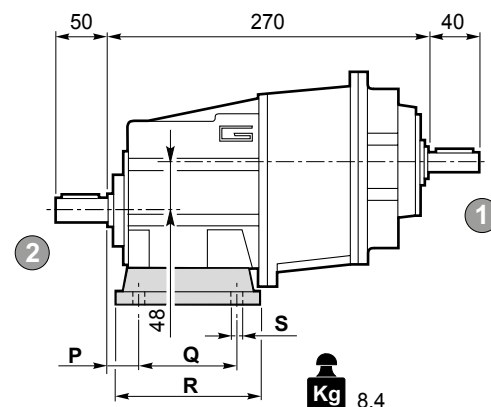
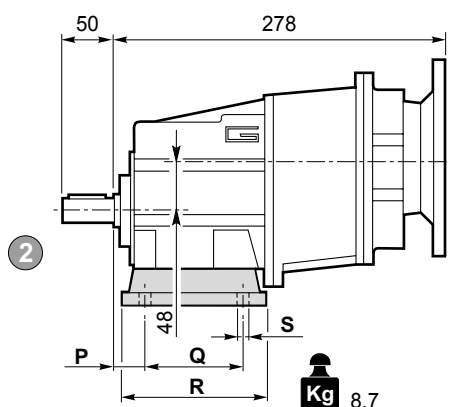

Versione H / H Version

CMG CMGIS	P	Q	R	S	U	V	X	Z	Piede / Foot	
									Tipo / Type	Peso / Weight [kg]
022 023	20	85	108	9	115	12	65	139	H65	0.7
	18	80	118	9	110	12	75	140	H75	1.0
	25	85	120	9	120	12	80	140	H80	1.1
	18	50 - 87	118	9	110	12	85	130	H85	1.2
	25	130	154	9	110	12	90	135	H90	1.5
	18	60 - 107.5	135	11	130	12	100	155	H100	1.7

Preferenziale / Preferred

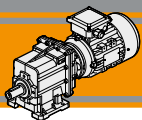

CMG 022 F.. - CMG 023 F..

CMG 022 F..

CMGIS 022 F..

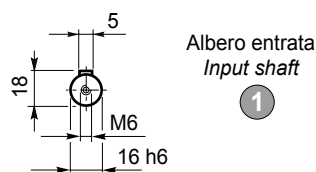
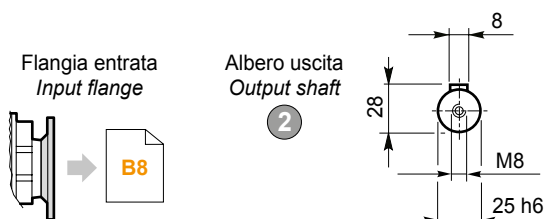
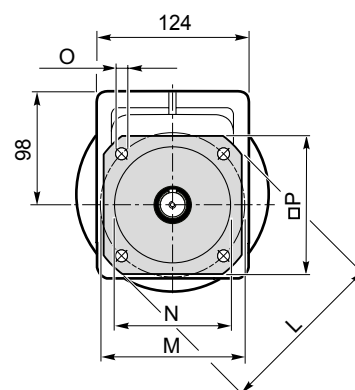
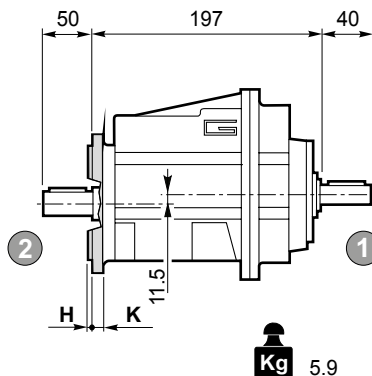
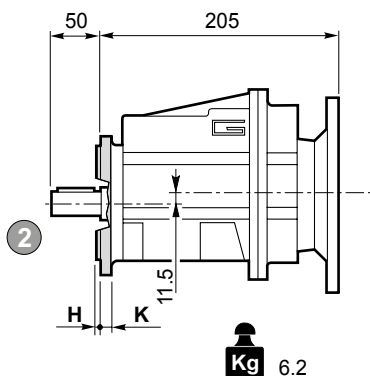

CMG 023 F..

CMGIS 023 F..

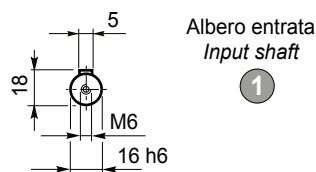
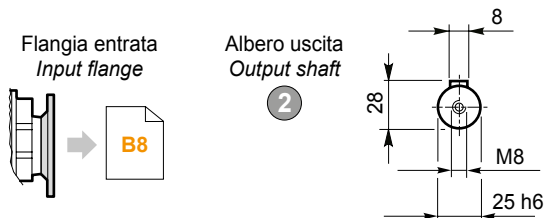
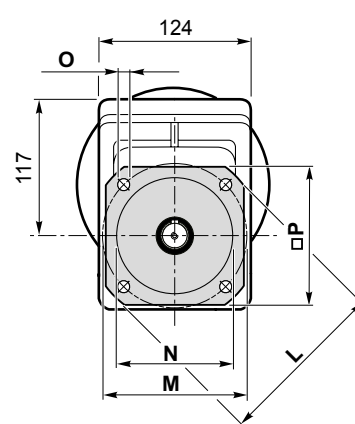
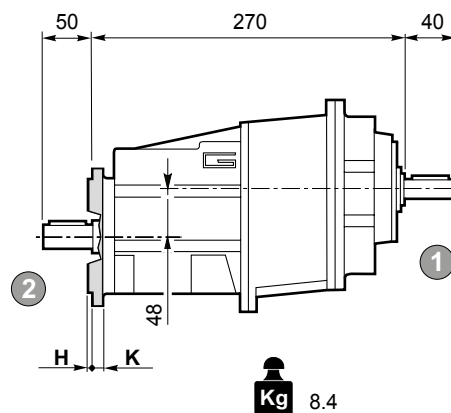
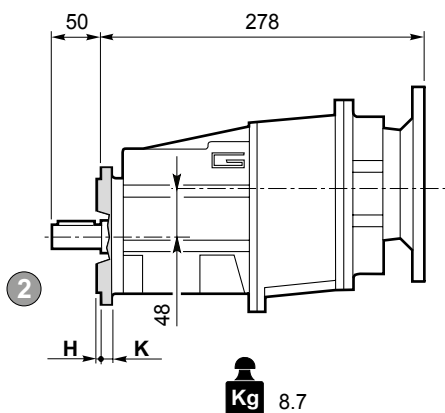

Versione F / F Version									
CMG CMGIS	H	K	L	M	N f7	O	P	Flangia / Flange	
								Tipo / Type	Peso / Weight [kg]
022 023	3	9	120	100	80	9	106	F120	0.5
	3.5	9	140	115	95	9	115	F140	0.8
	3.5	9	160	130	110	9	126	F160	1.1
	3.5	11	200	165	130	11	165	F200	1.8

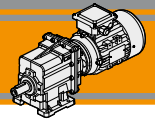

Dimensioni

Dimensions

CMG 022 H../F.. - CMG 023 H../F..

CMG 022 H../F..

CMGIS 022 H../F..

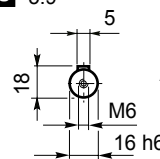
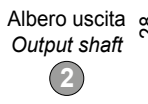
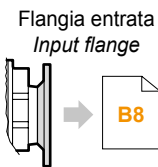
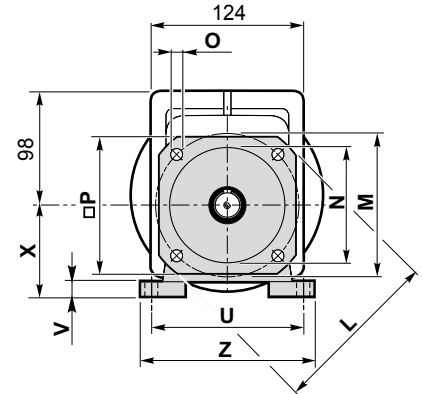
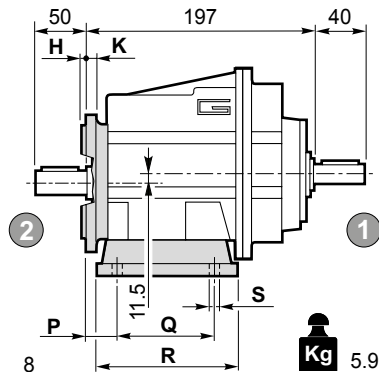
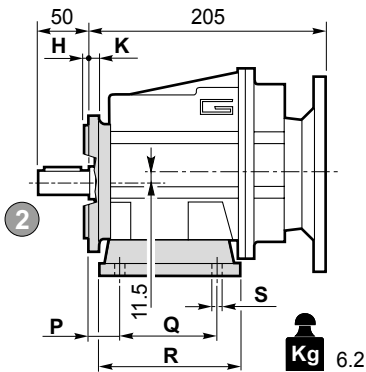

CMG 023 H../F..

CMGIS 023 H../F..

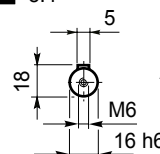
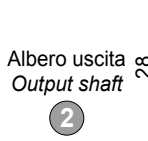
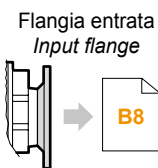
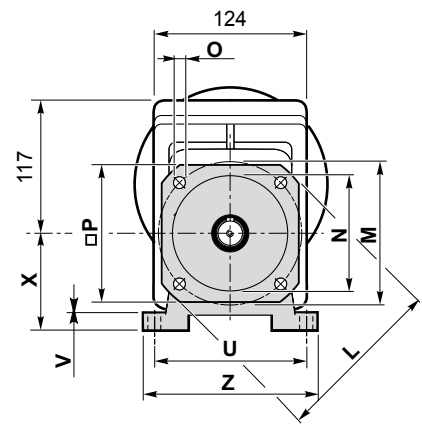
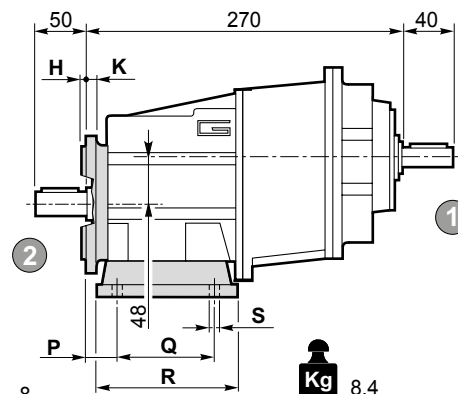
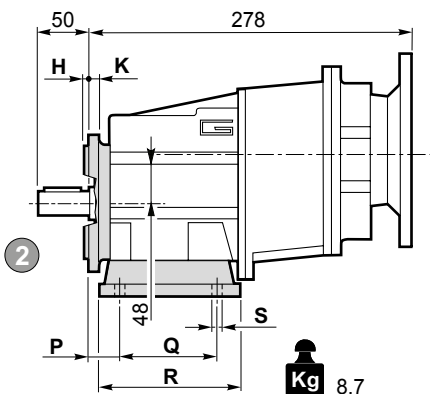

CMG CMGIS	Versione H / H Version								Combinazioni possibili H/F Possible combinations H/F					
	P	Q	R	S	U	V	X	Z	Piede / Foot		F120	F140	F160	F200
									Tipo Type	Peso / Weight [kg]				
022 023	20	85	108	9	115	12	65	139	H65	0.7	•	•		
	18	80	118	9	110	12	75	140	H75	1.0	•	•	•	
	25	85	120	9	120	12	80	140	H80	1.1	•	•	•	
	18	50 - 87	118	9	110	12	85	130	H85	1.2	•	•	•	
	25	130	154	9	110	12	90	135	H90	1.5	•	•	•	•
	18	60 - 107.5	135	11	130	12	100	155	H100	1.7	•	•	•	•

Preferenziale / Preferred

• Combinazioni possibili H/F / Possible combinations H/F

CMG CMGIS	Versione F / F Version								Flangia / Flange	
	H	K	L	M	N f7	O	P	Flangia / Flange		
								Tipo / Type	Peso / Weight [kg]	
022 023	3	9	120	100	80	9	106	F120	0.5	
	3.5	9	140	115	95	9	115	F140	0.8	
	3.5	9	160	130	110	9	126	F160	1.1	
	3.5	11	200	165	130	11	165	F200	1.8	

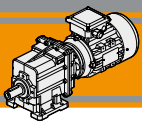
**CMG**

Motoriduttori ad ingranaggi cilindrici
Helical in-line gearmotors

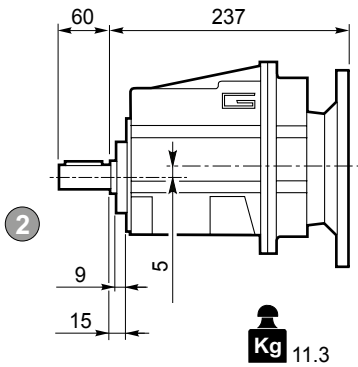
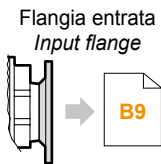
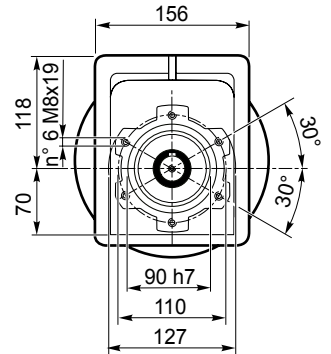
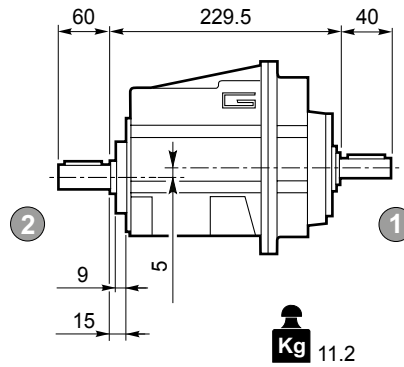
Dimensioni**Dimensions****CMG 032 U - CMG 033 U****CMG 032 U****CMGIS 032 U**

Albero uscita
Output shaft

2

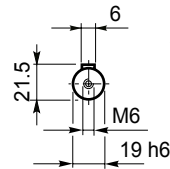
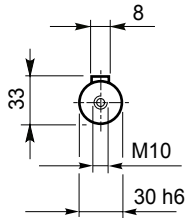

Albero entrata
Input shaft

1

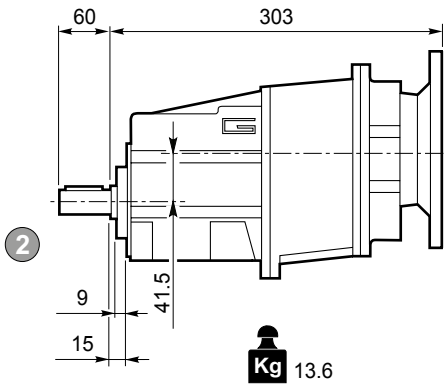
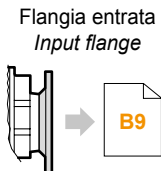
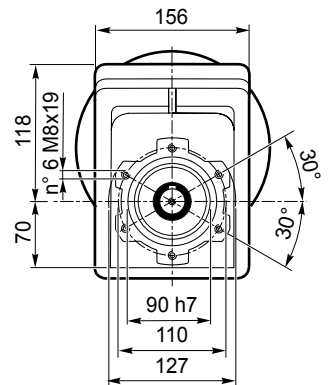
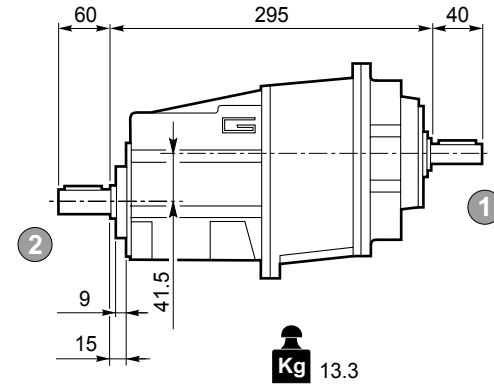
CMG 033 U**CMGIS 033 U**

Albero uscita
Output shaft

2

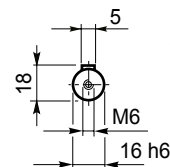
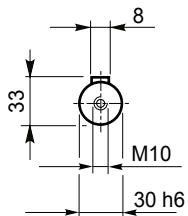

Albero entrata
Input shaft

1

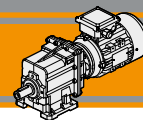

Dimensioni

Dimensions

CMG 032 H.. - CMG 033 H..

CMG 032 H..

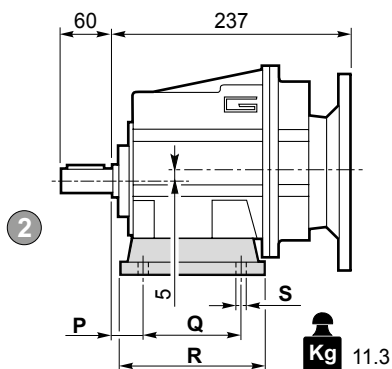

CMGIS 032 H..

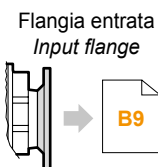
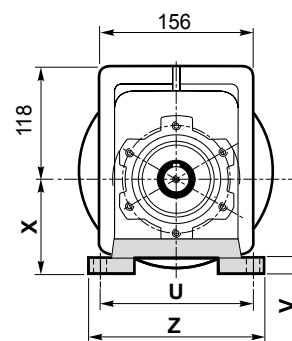
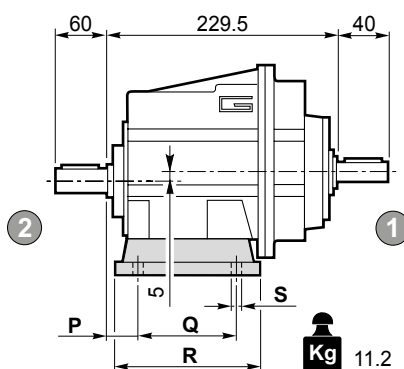

Flangia entrata
Input flange

Albero uscita
Output shaft

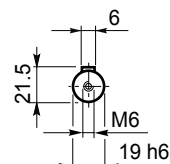
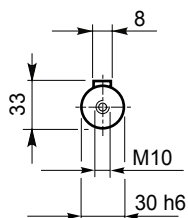

Albero entrata
Input shaft



CMG 033 H..

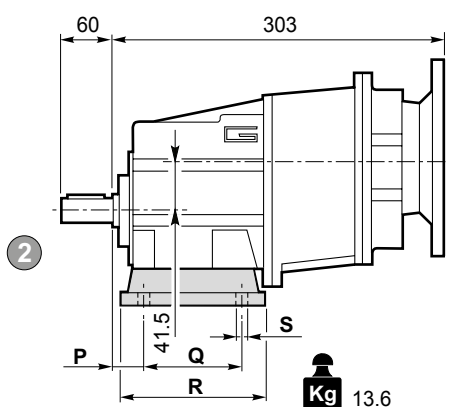

CMGIS 033 H..

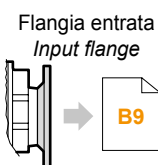
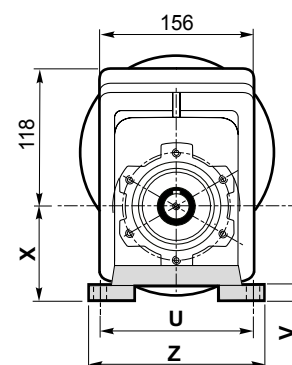
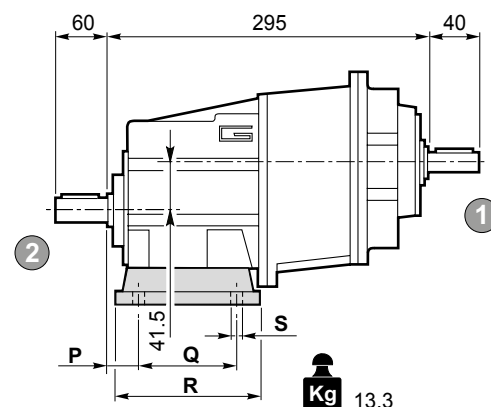

Flangia entrata
Input flange

Albero uscita
Output shaft

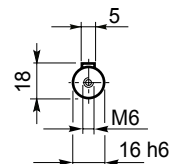
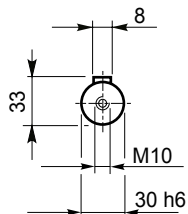

Albero entrata
Input shaft



Versione H / H Version

CMG CMGIS	P	Q	R	S	U	V	X	Z	Piede / Foot	
									Tipo / Type	Peso / Weight [kg]
032 033	30	105	136	14	160	14	95	194	H95	1.5
	30	100	150	11	150	14	110	185	H110	1.9
	18	70			160					
	30	165	195	14	135	14	115	170	H115	2.2
	35	110	160	14	170	14	120	210	H120	2.6
	19.5	149.5	184	14	180	18	130	214	H130	2.9

Preferenziale / Preferred

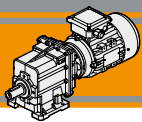

CMG

Motoriduttori ad ingranaggi cilindrici
Helical in-line gearmotors

Dimensioni

Dimensions

CMG 032 F.. - CMG 033 F..

CMG 032 F..

CMGIS 032 F..

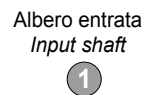
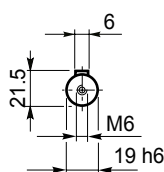
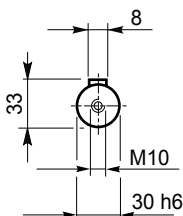
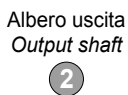
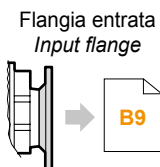
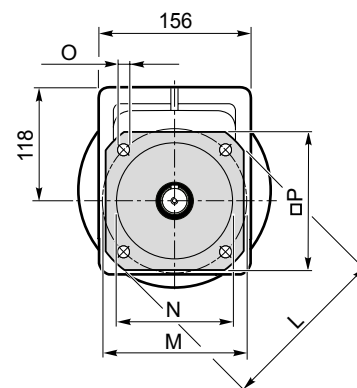
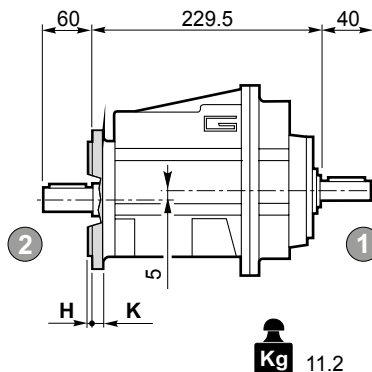
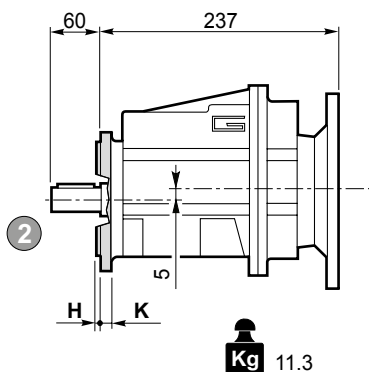

CMG 033 F..

CMGIS 033 F..

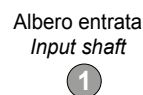
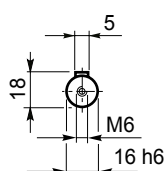
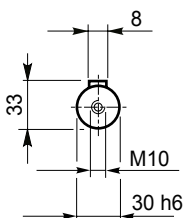
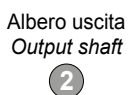
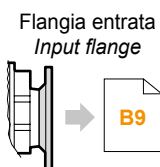
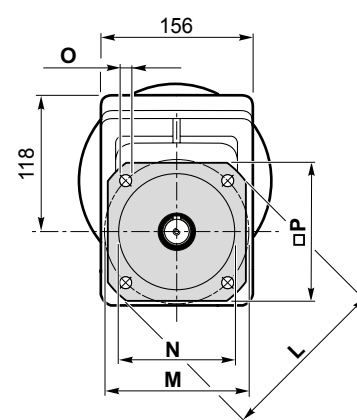
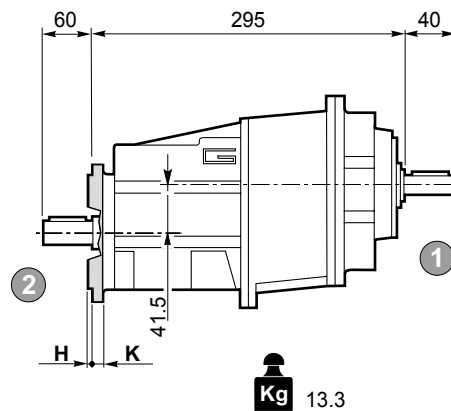
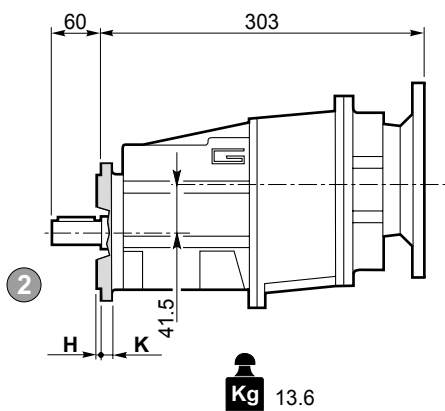

Versione F / F Version

CMG CMGIS	H	K	L	M	N f7	O	P	Flangia / Flange	
								Tipo / Type	Peso / Weight [kg]
032 033	3.5	11	160	130	110	9	140	F160	1.0
	3.5	11	200	165	130	11	165	F200	1.8
	4	13	250	215	180	14	215	F250	2.9

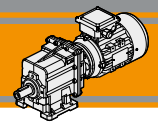

CMG 032 H../F.. - CMG 033 H../F..

CMG 032 H../F..

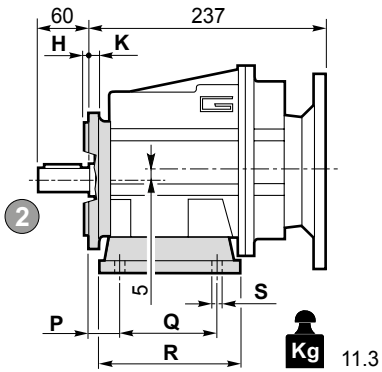

Kg 11.3

CMGIS 032 H../F..

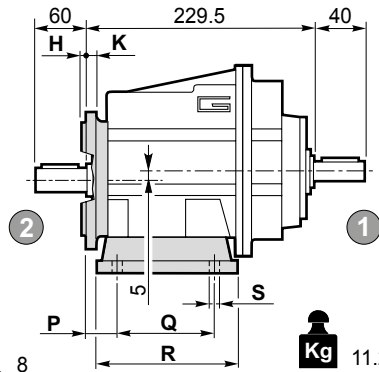

Kg 11.2

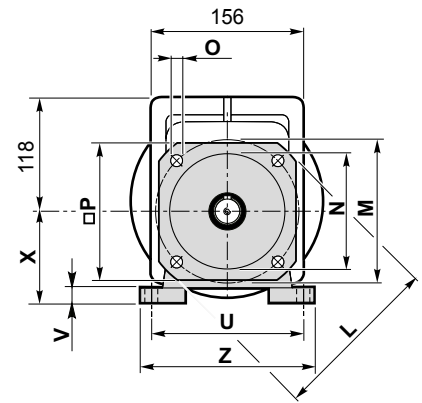

Flangia entrata
Input flange

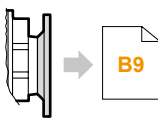

Albero uscita
Output shaft

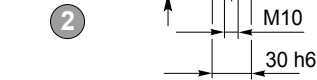

Albero entrata
Input shaft

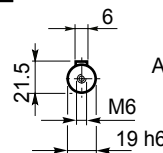

CMG 033 H../F..

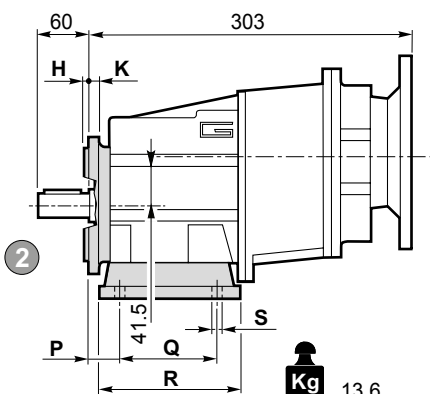

Kg 13.6

CMGIS 033 H../F..

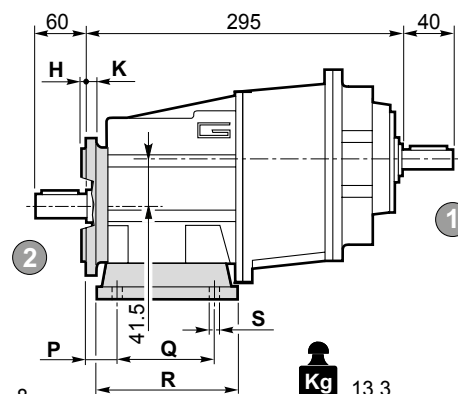

Kg 13.3

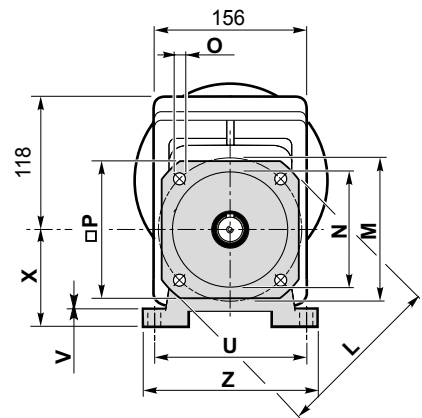

Flangia entrata
Input flange

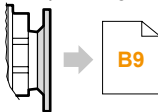

Albero uscita
Output shaft

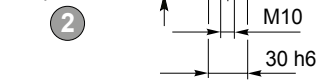

Albero entrata
Input shaft

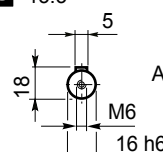

CMG CMGIS	Versione H / H Version									Combinazioni possibili H/F Possible combinations H/F			
	P	Q	R	S	U	V	X	Z	Piede / Foot		F160	F200	F250
									Tipo / Type	Peso / Weight [kg]			
032 033	30	105	136	14	160	14	95	194	H95	1.5	•	•	
	30	100	150	11	150	14	110	185	H110	1.9	•	•	
	18	70			160								
	30	165	195	14	135	14	115	170	H115	2.2	•	•	•
	35	110	160	14	170	14	120	210	H120	2.6	•	•	•
19.5	149.5	184	14	180	18	130	214	H130	2.9	•	•	•	

Preferenziale / Preferred

• Combinazioni possibili H/F / Possible combinations H/F

CMG CMGIS	Versione F / F Version								Flangia / Flange	
	H	K	L	M	N f7	O	P	Flangia / Flange		
								Tipo / Type	Peso / Weight [kg]	
032 033	3.5	11	160	130	110	9	140	F160	1.0	
	3.5	11	200	165	130	11	165	F200	1.8	
	4	13	250	215	180	14	215	F250	2.9	

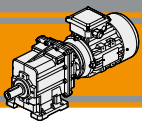
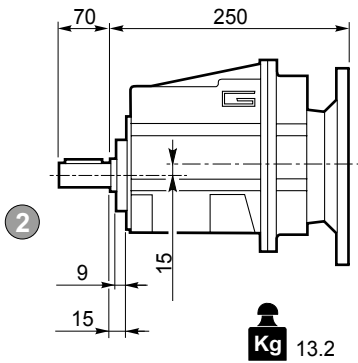
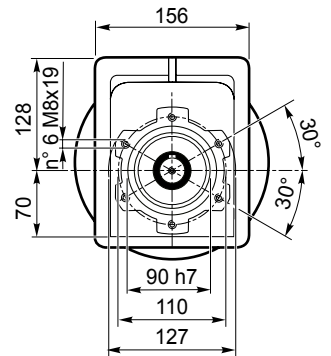
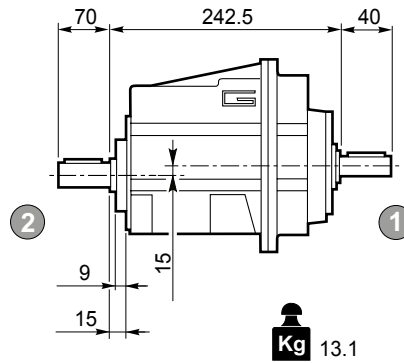
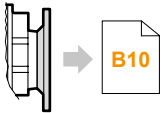
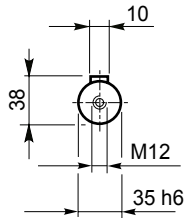
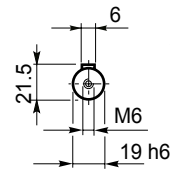
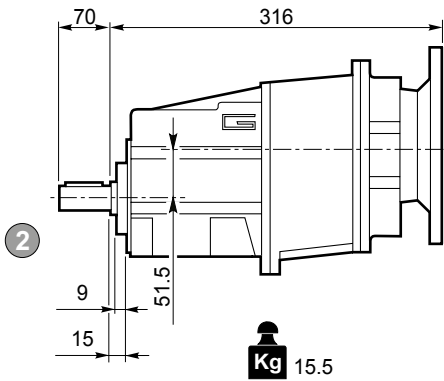
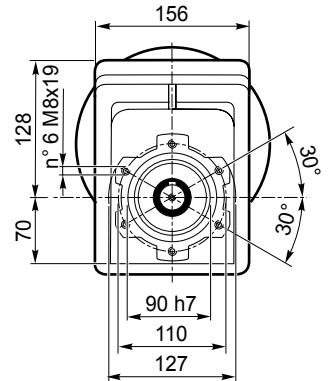
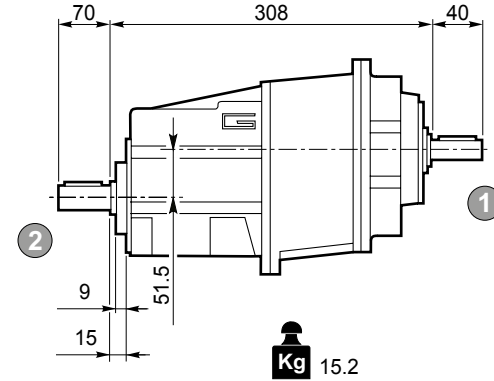
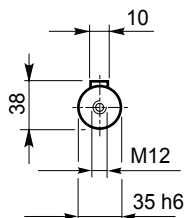
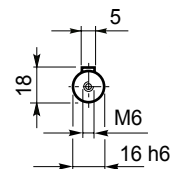
**Dimensioni****Dimensions****CMG 042 U - CMG 043 U****CMG 042 U****CMGIS 042 U**Flangia entrata
Input flangeAlbero uscita
Output shaftAlbero entrata
Input shaft**CMG 043 U****CMGIS 043 U**Flangia entrata
Input flangeAlbero uscita
Output shaftAlbero entrata
Input shaft

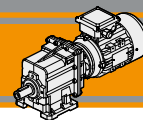

Dimensioni

Dimensions

CMG 042 H.. - CMG 043 H..

CMG 042 H..

CMGIS 042 H..

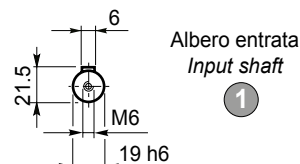
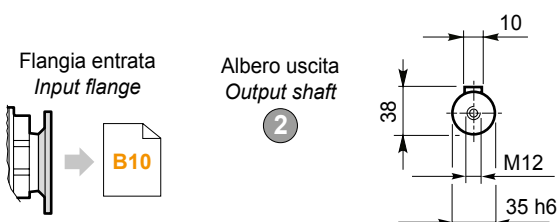
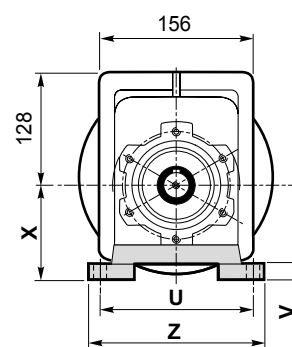
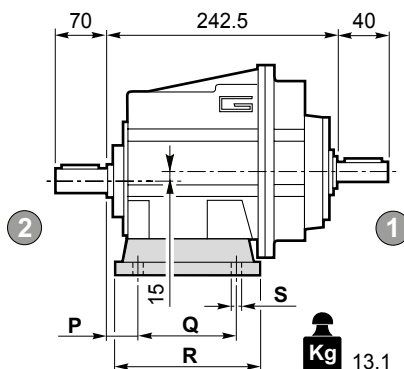
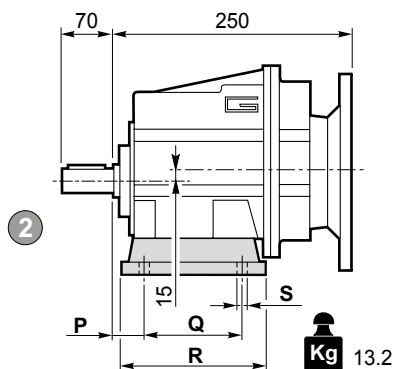

CMG 043 H..

CMGIS 043 H..

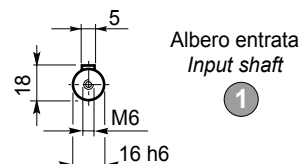
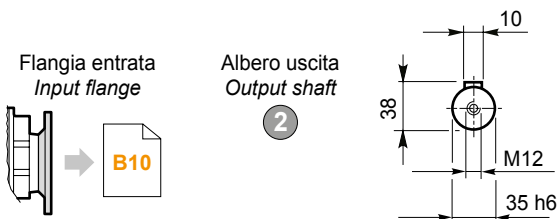
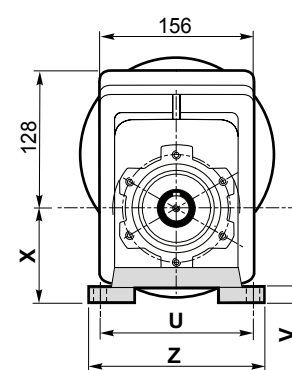
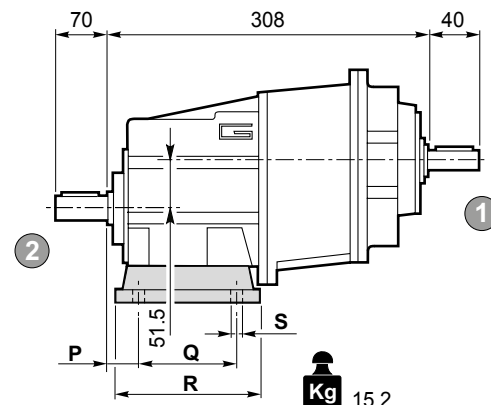
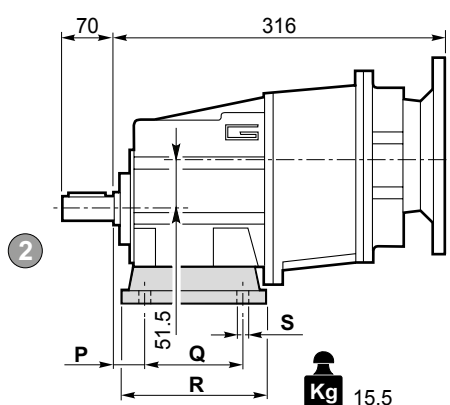

Versione H / H Version										
CMG CMGIS	P	Q	R	S	U	V	X	Z	Piede / Foot	
									Tipo / Type	Peso / Weight [kg]
042 043	30	105	136	14	160	14	95	194	H95	1.5
	30	100	150	11	150	14	110	185	H110	1.9
	18	70		160						
	30	165	195	14	135	14	115	170	H115	2.2
	35	110	160	14	170	14	120	210	H120	2.6
	19.5	149.5	184	14	180	18	130	214	H130	2.9

Preferenziale / Preferred



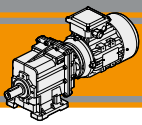

CMG 042 F.. - CMG 043 F..

CMG 042 F..

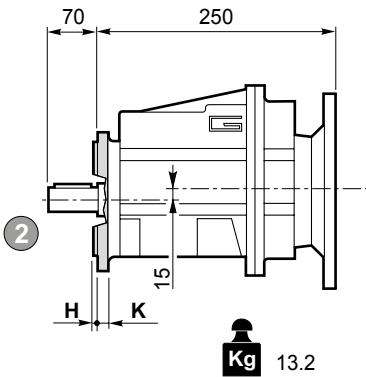

CMGIS 042 F..

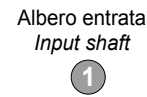
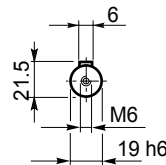
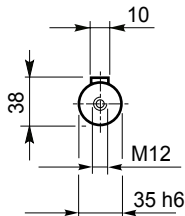
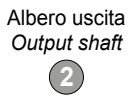
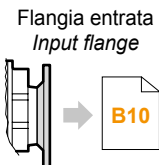
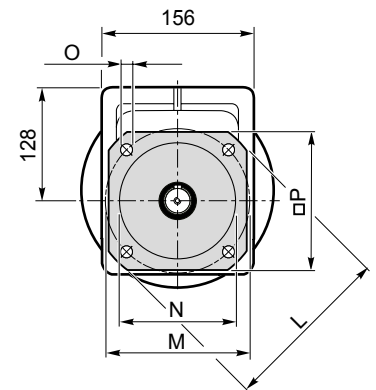
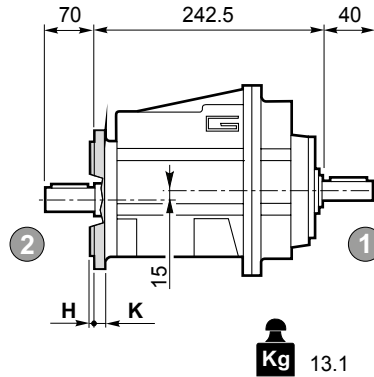

CMG 043 F..

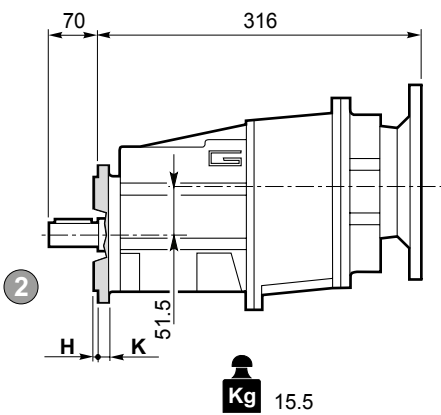

CMGIS 043 F..

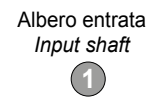
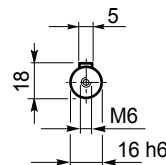
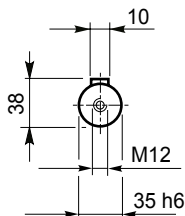
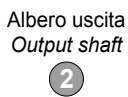
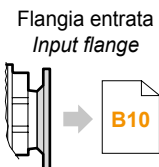
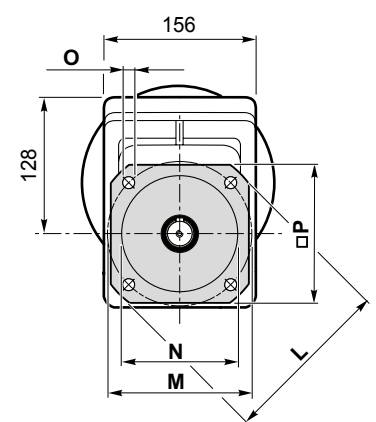
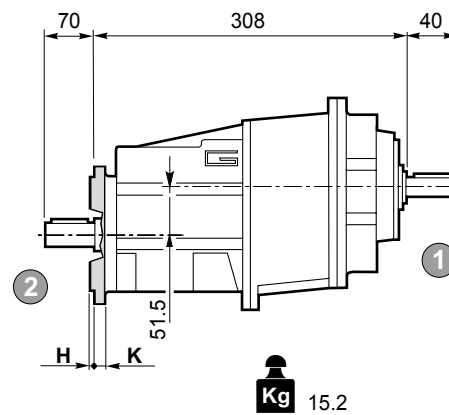

Versione F / F Version

CMG CMGIS	H	K	L	M	N f7	O	P	Flangia / Flange	
								Tipo / Type	Peso / Weight [kg]
042 043	3.5	11	160	130	110	9	140	F160	1.0
	3.5	11	200	165	130	11	165	F200	1.8
	4	13	250	215	180	14	215	F250	2.9

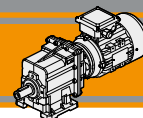

Dimensioni

Dimensions

CMG 042 H../F.. - CMG 043 H../F..

CMG 042 H../F..

CMGIS 042 H../F..

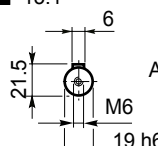
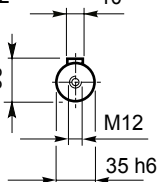
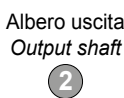
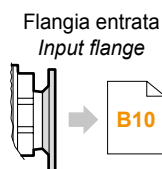
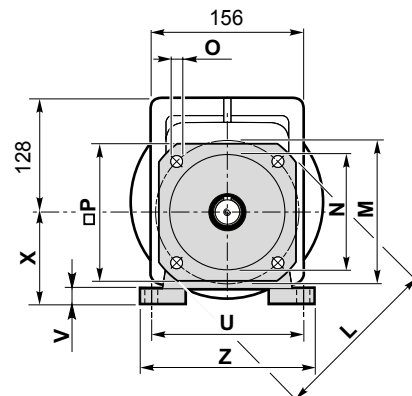
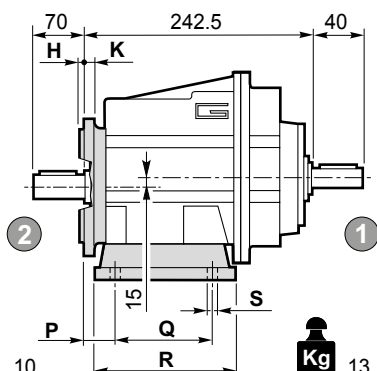
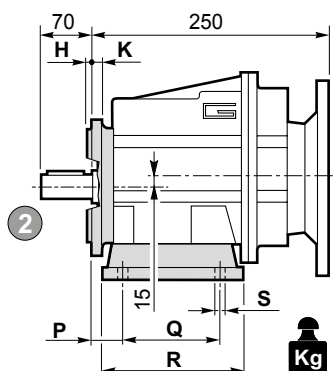

CMG 043 H../F..

CMGIS 043 H../F..

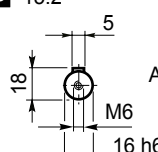
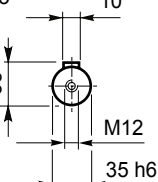
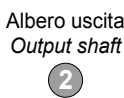
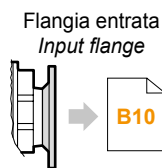
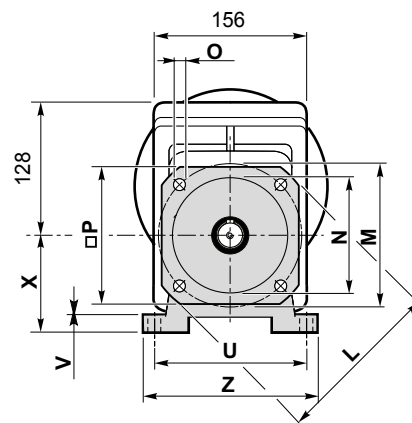
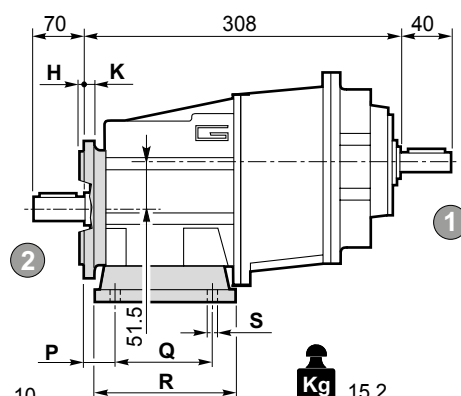
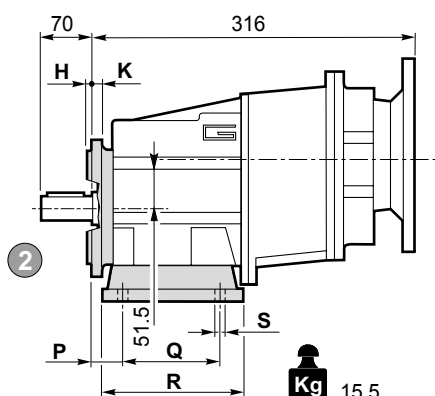

CMG CMGIS	Versione H / H Version									Combinazioni possibili H/F Possible combinations H/F			
	P	Q	R	S	U	V	X	Z	Piede / Foot		F160	F200	F250
									Tipo Type	Peso / Weight [kg]			
042 043	30	105	136	14	160	14	95	194	H95	1.5	•	•	
	30	100	150	11	150	14	110	185	H110	1.9	•	•	
	18	70			160								
	30	165	195	14	135	14	115	170	H115	2.2	•	•	•
	35	110	160	14	170	14	120	210	H120	2.6	•	•	•
	19.5	149.5	184	14	180	18	130	214	H130	2.9	•	•	•

Preferenziale / Preferred

• Combinazioni possibili H/F / Possible combinations H/F

CMG CMGIS	Versione F / F Version								Flangia / Flange	
	H	K	L	M	N f7	O	P	Flangia / Flange		
								Tipo / Type	Peso / Weight [kg]	
042 043	3.5	11	160	130	110	9	140	F160	1.0	
	3.5	11	200	165	130	11	165	F200	1.8	
	4	13	250	215	180	14	215	F250	2.9	



Архангельск (8182)63-90-72	Калининград (4012)72-03-81	Нижний Новгород (831)429-08-12	Смоленск (4812)29-41-54
Астана (7172)727-132	Калуга (4842)92-23-67	Новокузнецк (3843)20-46-81	Сочи (862)225-72-31
Белгород (4722)40-23-64	Кемерово (3842)65-04-62	Новосибирск (383)227-86-73	Ставрополь (8652)20-65-13
Брянск (4832)59-03-52	Киров (8332)68-02-04	Орел (4862)44-53-42	Тверь (4822)63-31-35
Владивосток (423)249-28-31	Краснодар (861)203-40-90	Оренбург (3532)37-68-04	Томск (3822)98-41-53
Волгоград (844)278-03-48	Красноярск (391)204-63-61	Пенза (8412)22-31-16	Тула (4872)74-02-29
Вологда (8172)26-41-59	Курск (4712)77-13-04	Пермь (342)205-81-47	Тюмень (3452)66-21-18
Воронеж (473)204-51-73	Липецк (4742)52-20-81	Ростов-на-Дону (863)308-18-15	Ульяновск (8422)24-23-59
Екатеринбург (343)384-55-89	Магнитогорск (3519)55-03-13	Рязань (4912)46-61-64	Уфа (347)229-48-12
Иваново (4932)77-34-06	Москва (495)268-04-70	Самара (846)206-03-16	Челябинск (351)202-03-61
Ижевск (3412)26-03-58	Мурманск (8152)59-64-93	Санкт-Петербург (812)309-46-40	Череповец (8202)49-02-64
Казань (843)206-01-48	Набережные Челны (8552)20-53-41	Саратов (845)249-38-78	Ярославль (4852)69-52-93

Единый адрес для всех регионов: ton@nt-rt.ru || www.transtecno.nt-rt.ru