

CMM

CMM



NEMA DIMENSIONS

Сдвоенные червячные мотор-редукторы

Руководство по эксплуатации

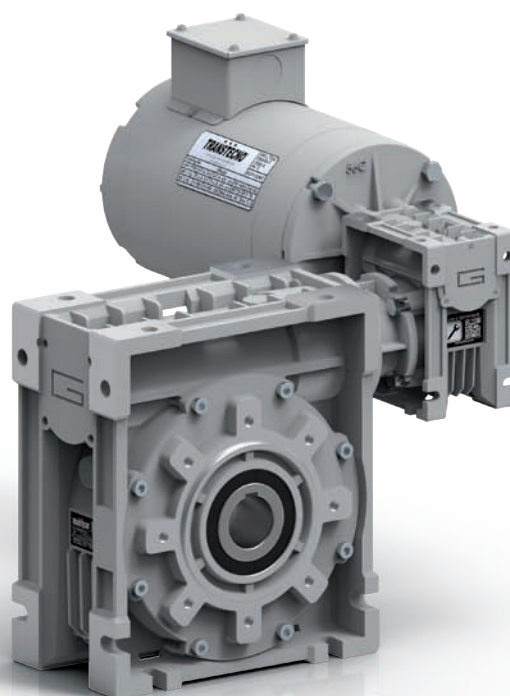

Архангельск (8182)63-90-72
Астана (7172)727-132
Белгород (4722)40-23-64
Брянск (4832)59-03-52
Владивосток (423)249-28-31
Волгоград (844)278-03-48
Вологда (8172)26-41-59
Воронеж (473)204-51-73
Екатеринбург (343)384-55-89
Иваново (4932)77-34-06
Ижевск (3412)26-03-58
Казань (843)206-01-48

Калининград (4012)72-03-81
Калуга (4842)92-23-67
Кемерово (3842)65-04-62
Киров (8332)68-02-04
Краснодар (861)203-40-90
Красноярск (391)204-63-61
Курск (4712)77-13-04
Липецк (4742)52-20-81
Магнитогорск (3519)55-03-13
Москва (495)268-04-70
Мурманск (8152)59-64-93
Набережные Челны (8552)20-53-41

Нижний Новгород (831)429-08-12
Новокузнецк (3843)20-46-81
Новосибирск (383)227-86-73
Орел (4862)44-53-42
Оренбург (3532)37-68-04
Пенза (8412)22-31-16
Пермь (342)205-81-47
Ростов-на-Дону (863)308-18-15
Рязань (4912)46-61-64
Самара (846)206-03-16
Санкт-Петербург (812)309-46-40
Саратов (845)249-38-78

Смоленск (4812)29-41-54
Сочи (862)225-72-31
Ставрополь (8652)20-65-13
Тверь (4822)63-31-35
Томск (3822)98-41-53
Тула (4872)74-02-29
Тюмень (3452)66-21-18
Ульяновск (8422)24-23-59
Уфа (347)229-48-12
Челябинск (351)202-03-61
Череповец (8202)49-02-64
Ярославль (4852)69-52-93

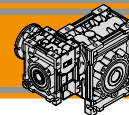

Índice	Index	Pág. Page
Características técnicas	<i>Technical features</i>	E2
Clasificación	<i>Classification</i>	E2
Nomenclatura	<i>Legend</i>	E2
Ejecución de montaje	<i>Mounting executions</i>	E3
Relaciones combinadas	<i>Combination ratio</i>	E3
Lubricación	<i>Lubrication</i>	E3
Datos técnicos	<i>Technical data</i>	E4
Motores aplicables	<i>IEC Motor adapters</i>	E8
Dimensiones	<i>Dimensions</i>	E10
Accesorios	<i>Accessories</i>	E14
Opciones	<i>Options</i>	E14

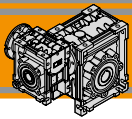

CMM

REDUCTORES SINFIN Y CORONA DOBLE REDUCCION
DOUBLE REDUCTION WORM-WORM GEARBOXES

Características técnicas

Technical features

El rango de combinación de los reductores CMM tienen las siguientes características principales:

CMM range double reduction worm-worm gearboxes have the following main features:

- Caja de aluminio para tamaños 040, 050, 063, 075, 090 y 110. El tamaño 130 tiene carcasa de hierro fundido;
- Doble rodamiento de rodillos cónicos en tamaños 090, 110 y 130;
- Lubricación permanente con aceite sintético.
- Die-cast aluminum housing on sizes 040, 050, 063, 075, 090 and 110. Cast iron housing on size 130;
- Double taper roller bearing on sizes 090, 110 and 130;
- Permanent synthetic oil long-life lubrication.

Clasificación

Classification

REDUCTOR / GEARBOX									
CMM	040/075	FD	300	56C	SZDX	BRSX	90	M1	US1
Tipo Type	Tamaño Size	Versión Version	Relación de reducción Ratio		Eje de salida Output shaft	Brazo de reacción Torque arm	Ángulo Angle	Posición de montaje Mounting position	Ejecución de montaje Mounting execution
CMM 	040/075 040/090 050/110 063/130	U FD FS FBD FBS FLD FLS	véase tablas see tables	56C 140TC	SZDX SZSX DZ	BRSX BRDX	0° 90° 180° 270°	M1 (B3) M2 (V6) M3 (B8) M4 (V5) M5 (B7) M6 (B6)	UB1 UB2 US1 US2 UV1 UV2 UC1 UC2

Relación de reducción
Gearbox Version

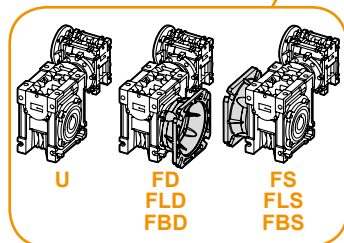

F.....D = Lado derecho / Right side
 FL = Brida larga / Long flange
 F.....S = Lado izquierdo / Left side
 FB = Brida corta / Short flange

Eje de salida
Output shaft

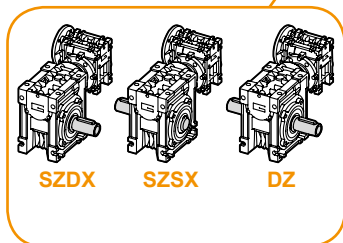

SZDX = Flecha sencilla lado derecho
Single shaft right side
 DZ = Flecha doble / Double shaft
 SZSX = Flecha sencilla lado izquierdo
Single shaft left side

Brazo de reacción
Torque arm

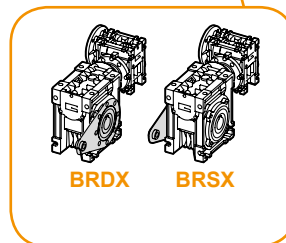

BRDX = Lado derecho / Right side
 BRSX = Lado izquierdo / Left side

Ángulo
Angle

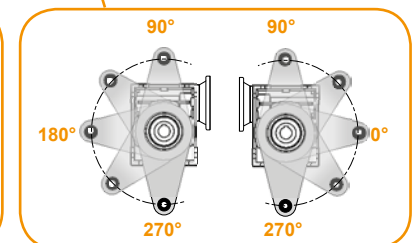

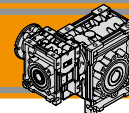

Clasificación

Classification

MOTOR / MOTOR					
1 hp / 0.75kW	4p	3ph	220/440V	60Hz	T1
Potencia Power	Polos Poles	Fases Phases	Tensión Voltage	Frecuencia Frequency	Posición caja de bornes Terminal box pos.
véase tablas See tables	2p 4p 6p 8p	1ph 3ph	230V 230/400V ... 220/440V	50Hz 60Hz	T1 (Std) T4 T2 T3

Nomenclatura

Legend

n_1 [rpm]	Velocidad de entrada / <i>Input speed</i>	M_2 [Nm]	Par en la salida en función de P_1 / <i>Output torque referred to P_1</i>
n_2 [rpm]	Velocidad de salida / <i>Output speed</i>	sf	Rendimiento dinámico / <i>Service factor</i>
i	Relación de reducción / <i>Ratio</i>	R_2 [N]	Carga radial admisible en la salida / <i>Maximum output radial load</i>
P_1 [kW]	Potencia en la entrada / <i>Input power</i>	A_2 [N]	Carga axial admisible en la salida / <i>Maximum output axial load</i>

Ejecución de montaje

Mounting executions

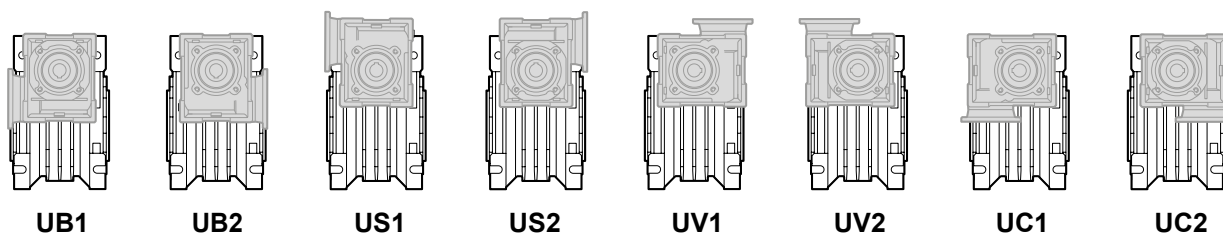

Relaciones combinadas

Combination ratio

CMM 040/075 - CMM 040/090 - CMM 050/110 - CMM 063/130																
$i (i_1 \times i_2)$																
	75	100	150	200	250	300	400	500	600	750	900	1200	1500	1800	2400	3000
i_1	7.5	10	10	10	10	10	10	10	20	25	30	40	50	60	60	60
i_2	10	10	15	20	25	30	40	50	30	30	30	30	30	30	40	50

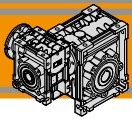

Lubricación

Lubrication

La lubricación permanente con aceite sintético de larga vida (grado de viscosidad 320) hace que sea posible el uso de los reductores tamaños 40, 50, 63, 75, 90 y 110 en todas las posiciones de montaje. Solo para el tamaño 130 la lubricación depende de la posición de montaje.

Permanent synthetic oil long-life lubrication (viscosity grade 320) makes it possible to use the gearboxes size 40, 50, 63, 75, 90, 110 in all mounting positions; for this reason they can be installed in any assembly position and do not require maintenance. Only for size 130, the lubrication depended of mounting positions

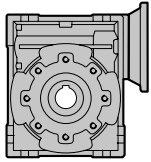

CM	Cantidad de aceite (US gal) / Oil quantity (US gal)					
	M1 (B3)	M3 (B8)	M6 (B6)	M5 (B7)	M4 (V5)	M2 (V6)
130	1.19	0.87	0.92	0.92	1.19	0.87

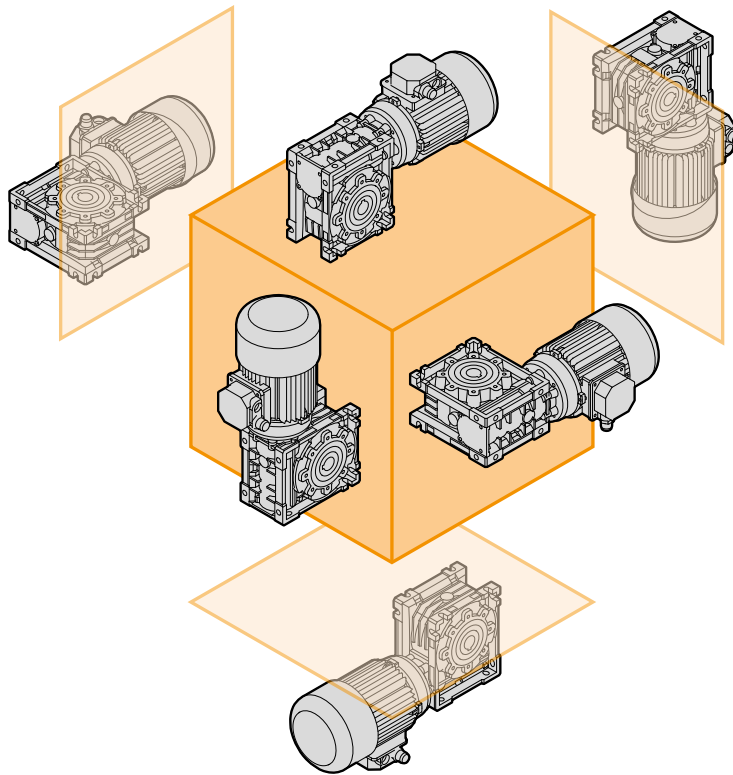

Posición de montaje / Mounting positions

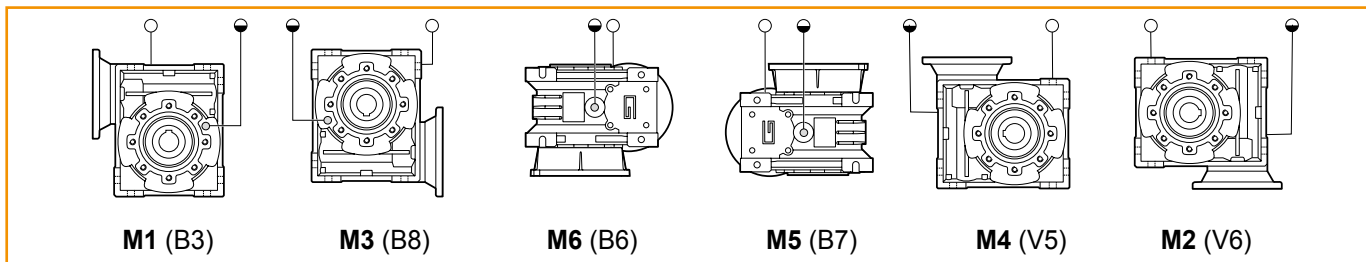



(standard)

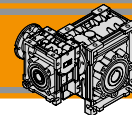

○ Respiradero y tapón de llenado / Breather and filling plug
● Tapón de nivel de aceite / Oil level plug



Datos técnicos

Technical data

P ₁ [hp]	n ₂ [rpm]	M ₂ [lb·in]	sf	AGMA	i		
------------------------	-------------------------	---------------------------	----	------	---	---	---

P ₁ [hp]	n ₂ [rpm]	M ₂ [lb·in]	sf	AGMA	i		
------------------------	-------------------------	---------------------------	----	------	---	---	---

0.16 hp

0.12 kW (1750 rpm)	2.92	2007	2.4	III	600	CMM 040/075	56C
	2.33	2380	2.0	III	750		56C
	1.94	2702	1.8	II	900		56C
	1.46	3345	1.4	II	1200		56C
	1.17	3860	1.3	I	1500		56C
	0.97	4478	1.1	I	1800		56C
	1.46	3513	2.4	III	1200	CMM 040/090	56C
		4053	2.1	III	1500		56C
		4702	1.8	II	1800		56C
		5771	1.2	I	2400		56C
		6717	0.9	I	3000		56C
		0.97	4941	2.9	III		1800
6279	2.0		III	2400	56C		
7463	1.5		II	3000	56C		
0.73	6809	2.4	III	2400	CMM 063/130	56C	
	8241	1.7	II	3000		56C	

0.33 hp

0.22 kW (1750 rpm)	8.75	1709	2.4	III	200	CMM 040/075	56C	
	7.00	2012	1.8	II	250		56C	
	5.83	2229	2.2	III	300		56C	
	4.38	2725	1.5	II	400		56C	
	3.50	3096	1.2	I	500		56C	
	2.92	4140	1.2	I	600		56C	
	2.33	4910	1.0	I	750	CMM 040/090	56C	
		5573	0.9	I	900		56C	
		2873	2.5	III	400		CMM 040/090	56C
		3344	1.8	II	500			56C
		4347	1.9	II	600			56C
		5155	1.6	II	750			56C
5852	1.4	II	900	56C				
7183	1.0	I	1200	56C				
1.17	8360	1.0	I	1500	CMM 040/090	56C		
	9697	0.9	I	1800		56C		
	5378	2.6	III	750		CMM 050/110	56C	
	6114	2.3	III	900			56C	
	7770	1.6	II	1200			56C	
	8917	1.6	II	1500			56C	
10191	1.4	I	1800	56C				
12951	1.0	I	2400	56C				
1.94	6568	2.8	III	900	CMM 063/130	56C		
	8360	1.9	II	1200		56C		
	9633	1.9	II	1500		56C		
	11035	1.7	II	1800		56C		
	14044	1.1	I	2400		56C		
	16998	0.8	I	3000		56C		

0.25 hp

0.18 kW (1750 rpm)	5.83	1689	2.9	III	300	CMM 040/075	56C	
	4.38	2064	2.0	III	400		56C	
	3.50	2346	1.5	II	500		56C	
	2.92	3136	1.5	II	600		56C	
	2.33	3719	1.3	I	750		56C	
	1.94	4222	1.1	I	900		56C	
	1.46	5160	0.8	I	1200	CMM 040/090	56C	
		2533	2.4	III	500		CMM 040/090	56C
		3293	2.5	III	600			56C
		3905	2.1	III	750			56C
		4433	1.9	II	900			56C
		5442	1.3	I	1200			56C
1.17	6333	1.3	I	1500	CMM 050/110	56C		
	7346	1.1	I	1800		56C		
	9018	0.8	I	2400		56C		
	5887	2.2	III	1200		CMM 050/110	56C	
	6755	2.1	III	1500			56C	
	7720	1.8	II	1800			56C	
9811	1.3	I	2400	56C				
11661	1.0	I	3000	56C				
1.46	6333	2.5	III	1200	CMM 063/130		56C	
	7298	2.5	III	1500		56C		
	8360	2.2	III	1800		56C		
	10639	1.5	II	2400		56C		
	12877	1.1	I	3000		56C		

0.5 hp

0.37 kW (1750 rpm)	11.67	2055	2.3	III	150	CMM 040/075	56C
	8.75	2589	1.6	II	200		56C
	7.00	3049	1.2	I	250		56C
	5.83	3378	1.4	II	300		56C
	4.38	4128	1.0	I	400		56C
	5.83	3546	2.4	III	300		CMM 040/090
		4353	1.7	II	400	56C	
		5066	1.2	I	500	56C	
		6586	1.3	I	600	56C	
		7811	1.1	I	750	56C	
		8866	0.9	I	900	56C	

CMM



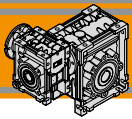





CMM

REDUCTORES SINFIN Y CORONA DOBLE REDUCCION
DOUBLE REDUCTION WORM-WORM GEARBOXES

Datos técnicos

Technical data

P ₁ [hp]	n ₂ [rpm]	M ₂ [lb·in]	sf	AGMA	i		
------------------------	-------------------------	---------------------------	----	------	---	---	---

P ₁ [hp]	n ₂ [rpm]	M ₂ [lb·in]	sf	AGMA	i		
------------------------	-------------------------	---------------------------	----	------	---	---	---

0.5 hp

0.37 kW (1750 rpm)	4.38	4633	2.8	III	400	CMM 050/110	56C	
	3.50	5506	2.0	III	500		56C	
	2.92	6519	2.2	III	600		56C	
	2.33	8149	1.7	II	750		56C	
	1.94	9264	1.5	II	900		56C	
	1.46	11773	1.1	I	1200		56C	
	1.17	13510	1.0	I	1500		56C	
	0.97	15440	0.9	I	1800		56C	
	2.92	7165	2.5	III	600		CMM 063/130	56C
	2.33	8625	2.1	III	750			56C
1.94	9952	1.8	II	900	56C			
1.46	12666	1.3	I	1200	56C			
1.17	14596	1.3	I	1500	56C			
0.97	16719	1.1	I	1800	56C			

1 hp

0.75 kW (1750 rpm)	23.33	2248	2.0	II	75	CMM 040/075	56C	
	17.50	2927	1.5	II	100		56C	
	11.67	4109	1.1	I	150		56C	
	8.75	5179	0.8	I	200		56C	
	11.67	4222	1.8	II	150		CMM 040/090	56C
	8.75	5404	1.3	I	200			56C
	7.00	6474	1.0	I	250			56C
	5.83	7093	1.2	I	300			56C
	4.38	8707	0.8	I	400			56C
	8.75	5620	2.2	III	200		CMM 050/110	56C
7.00	6836	1.7	II	250	56C			
5.83	7291	1.9	II	300	56C			
4.38	9266	1.4	I	400	56C			
3.50	11013	1.0	I	500	56C			
2.92	13039	1.1	I	600	56C			
2.33	16298	0.9	I	750	56C			
7.00	6604	2.2	III	250	CMM 063/130	56C-140TC		
5.83	7165	2.5	III	300		56C-140TC		
4.38	9120	1.8	II	400		56C-140TC		
3.50	11038	1.3	I	500		56C-140TC		
2.92	14331	1.3	I	600		56C-140TC		
2.33	17250	1.1	I	750		56C-140TC		
1.94	19904	0.9	I	900		56C-140TC		

0.75 hp

0.55 kW (1750 rpm)	23.33	1686	2.6	III	75	CMM 040/075	56C	
	17.50	2195	2.0	III	100		56C	
	11.67	3082	1.5	II	150		56C	
	8.75	3884	1.1	I	200		56C	
	7.00	4574	0.8	I	250		56C	
	11.67	3166	2.4	III	150		CMM 040/090	56C
	8.75	4053	1.8	II	200			56C
	7.00	4855	1.3	I	250			56C
	5.83	5320	1.6	II	300			56C
	4.38	6530	1.1	I	400			56C
3.50	7600	0.8	I	500	56C			
2.92	9879	0.8	I	600	56C			
7.00	5127	2.2	III	250	CMM 050/110	56C		
5.83	5468	2.6	III	300		56C		
4.38	6950	1.8	II	400		56C		
3.50	8260	1.4	I	500		56C		
2.92	9779	1.4	II	600		56C		
2.33	12224	1.2	I	750		56C		
1.94	13896	1.0	I	900	56C			
4.38	6840	2.4	III	400	CMM 063/130	56C		
3.50	8278	1.7	II	500		56C		
2.92	10748	1.7	II	600		56C		
2.33	12937	1.4	II	750		56C		
1.94	14928	1.2	I	900		56C		
1.46	18999	0.8	I	1200		56C		
1.17	21894	0.8	I	1500		56C		

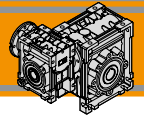

1.5 hp

1.1 kW (1750 rpm)	23.33	3372	1.3	I	75	CMM 040/075	56C	
	17.50	4391	1.0	I	100		56C	
	23.33	3458	1.9	II	75		CMM 040/090	56C
	17.50	4503	1.5	II	100			56C
	11.67	6333	1.2	I	150			56C
	8.75	8106	0.9	I	200			56C
	17.50	4614	2.6	III	100			CMM 050/110
	11.67	6494	2.0	III	150		56C	
	8.75	8431	1.5	II	200		56C	
	7.00	10253	1.1	I	250		56C	
5.83	10937	1.3	I	300	56C			
4.38	13899	0.9	I	400	56C			
11.67	6270	2.7	III	150	CMM 063/130	56C-140TC		
8.75	8142	2.0	II	200		56C-140TC		
7.00	9907	1.5	II	250		56C-140TC		
5.83	10748	1.7	II	300		56C-140TC		
4.38	13679	1.2	I	400		56C-140TC		
3.50	16556	0.9	I	500		56C-140TC		
2.92	21496	0.8	I	600		56C-140TC		



Datos técnicos

Technical data

P_1 [hp]	n_2 [rpm]	M_2 [lb·in]	sf	AGMA	i		
---------------	----------------	------------------	----	------	---	---	---

2 hp

1.5 kW (1750 rpm)	23.33	4495	1.0	I	75	CMM 040/075	56C			
	23.33	4611	1.4	II	75			CMM 040/090	56C	
	17.50	6005	1.1	I	100					56C
	11.67	8444	0.9	I	150					
	23.33	4723	2.5	III	75	CMM 050/110	56C			
	17.50	6152	1.9	II	100			56C		
	11.67	8658	1.5	II	150			56C		
	8.75	11241	1.1	I	200			56C		
	7.00	13671	0.8	I	250			56C		
	5.83	14583	1.0	I	300			56C		
	17.50	5935	2.5	III	100			CMM 063/130	56C-140TC	
	8.75	10857	1.5	II	200	56C-140TC				
	7.00	13209	1.1	I	250	56C-140TC				
	5.83	14331	1.3	I	300	56C-140TC				
4.38	18239	0.9	I	400	56C-140TC					

3 hp

2.2 kW (1750 rpm)	23.33	7254	2.0	III	75	CMM 063/130	140TC	
	17.50	8902	1.7	II	100			140TC
	8.75	16285	1.0	I	200			140TC
	5.83	21496	0.8	I	300			140TC

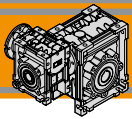

Motores Aplicables IEC

IEC Motor adapters

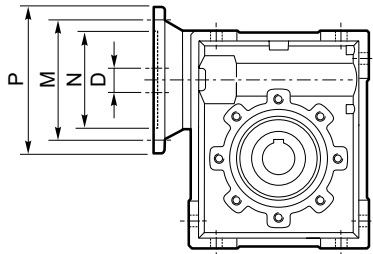

NOTA / NOTE

Las áreas grises indican la aplicabilidad del correspondiente tamaño del motor.

Grey areas indicate motor inputs available on each size of unit.

B/BS = Buje de metal para flecha

B/BS = Metal shaft sleeve

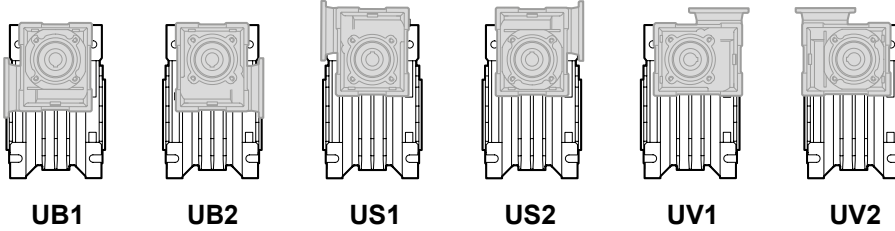

CMM	NEMA	N	M	P	D	i ₁								
						7.5	10	20	25	30	40	50	60	
040/075	56C	4.5	5.88	6.5	0.625									
040/090														
050/110														
063/130	140TC				0.875	B								

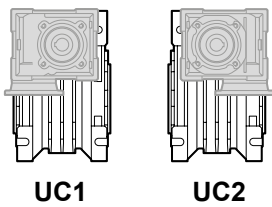

CMM	NEMA	N	M	P	D	i ₁							
						7.5	10	20	25	30	40	50	60
050/110	56C	4.5	5.88	6.5	0.625								
063/110						B							
		140TC				0.875							

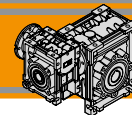

Dimensiones

Dimensions

CMM 040/075

CMM 040/075 U

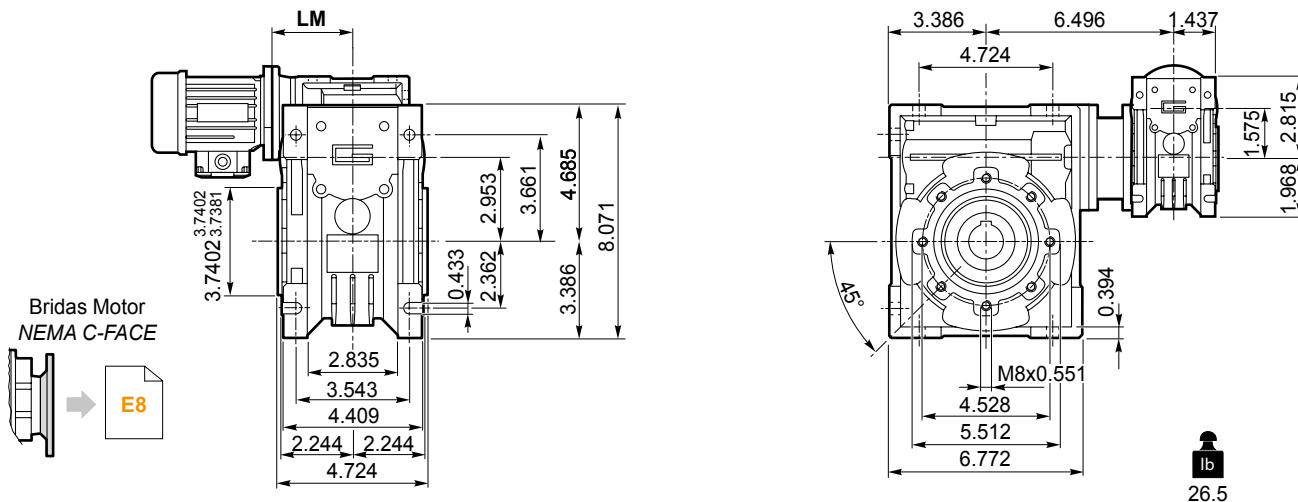

CMM 040/075 F

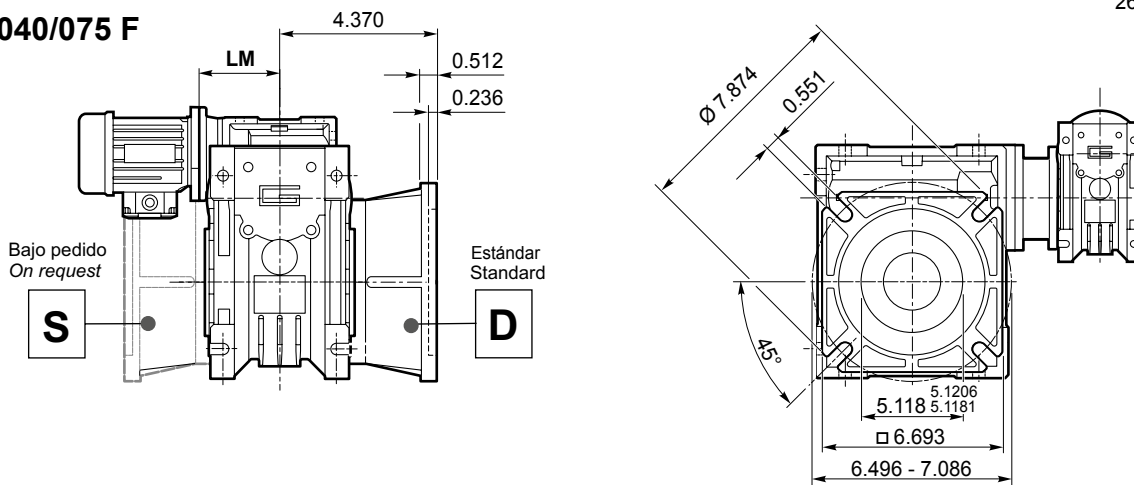

CMMIS 040/075 ..

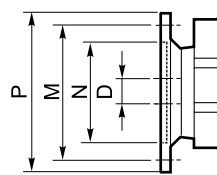
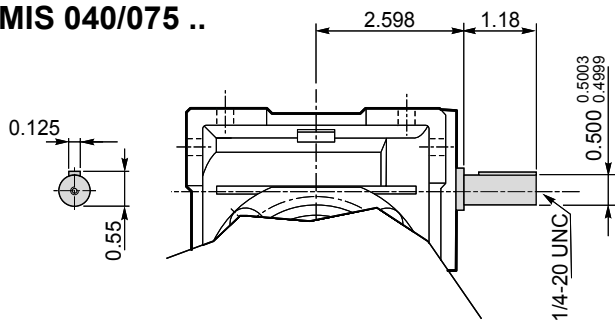

Brida Motor / Motor flange	
Dimensiones NEMA NEMA Dimensions	
	56 C
N	4.5
M	5.88
P	6.5
D	0.625
LM	3.15

Eje de salida hueco / Hollow output shaft

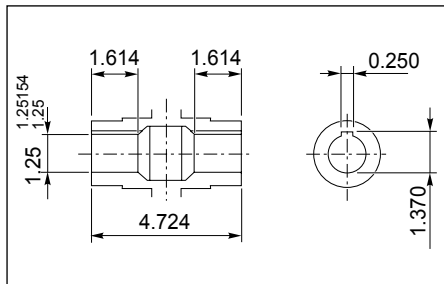

Eje de salida / Output shaft

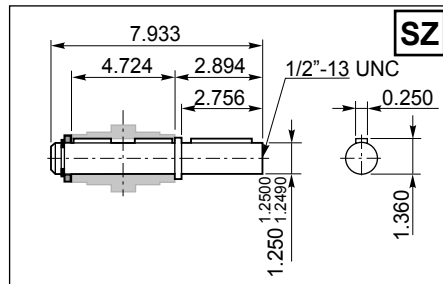

Eje de salida / Output shaft

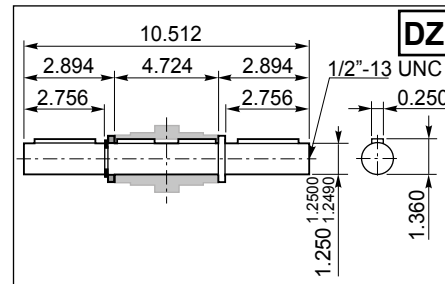

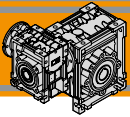

Dimensiones

Dimensions

CMM 040/090

CMM 040/090 U

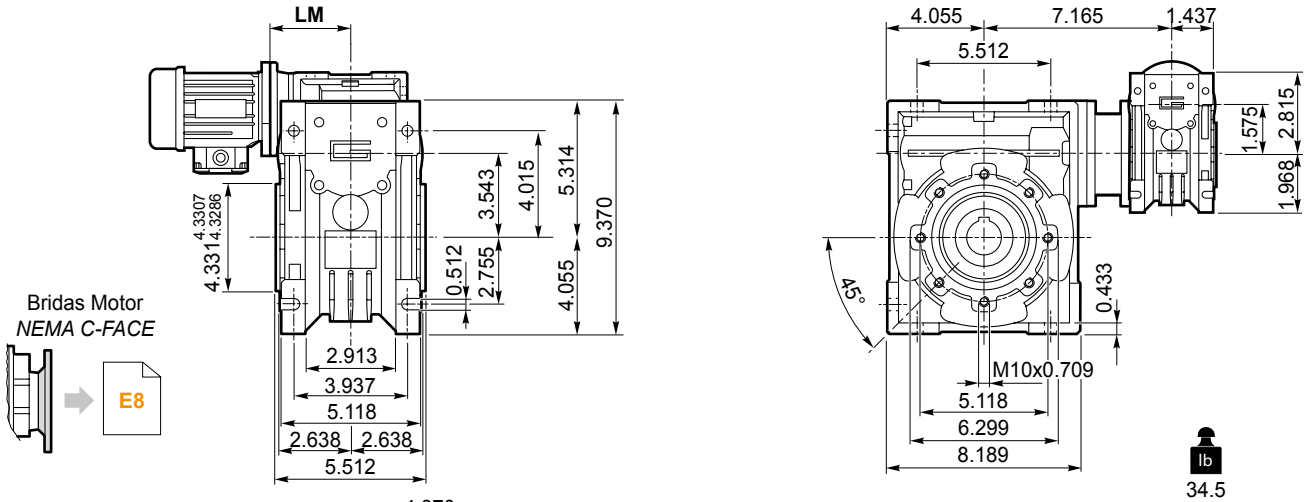

CMM 040/090 F

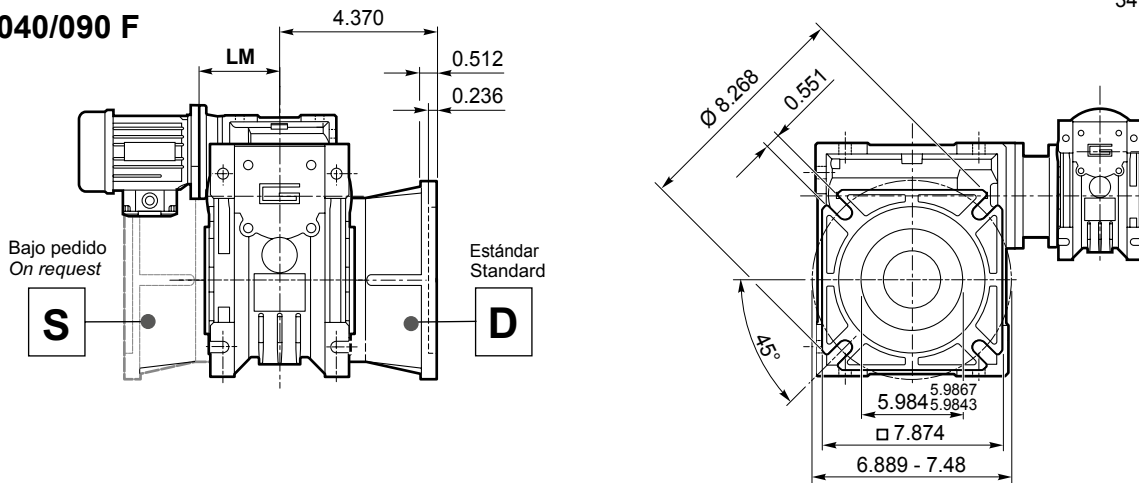

CMMIS 040/090 ..

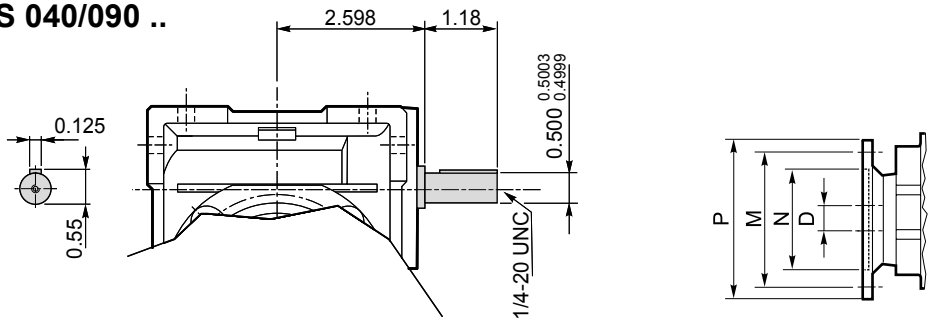

Brida Motor / Motor flange	
Dimensiones NEMA	
NEMA Dimensions	
	56 C
N	4.5
M	5.88
P	6.5
D	0.625
LM	3.15

Eje de salida hueco / Hollow output shaft

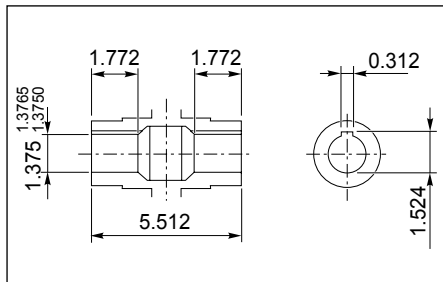

Eje de salida / Output shaft

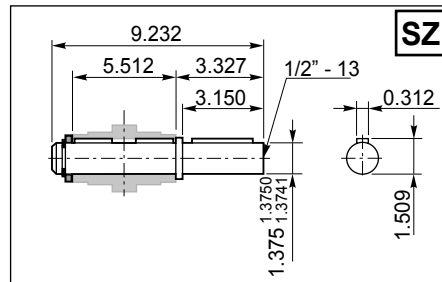

Eje de salida / Output shaft

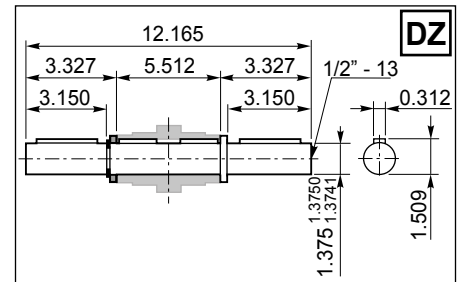

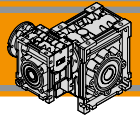

Dimensiones

Dimensions

CMM 050/110

CMM 050/110 U

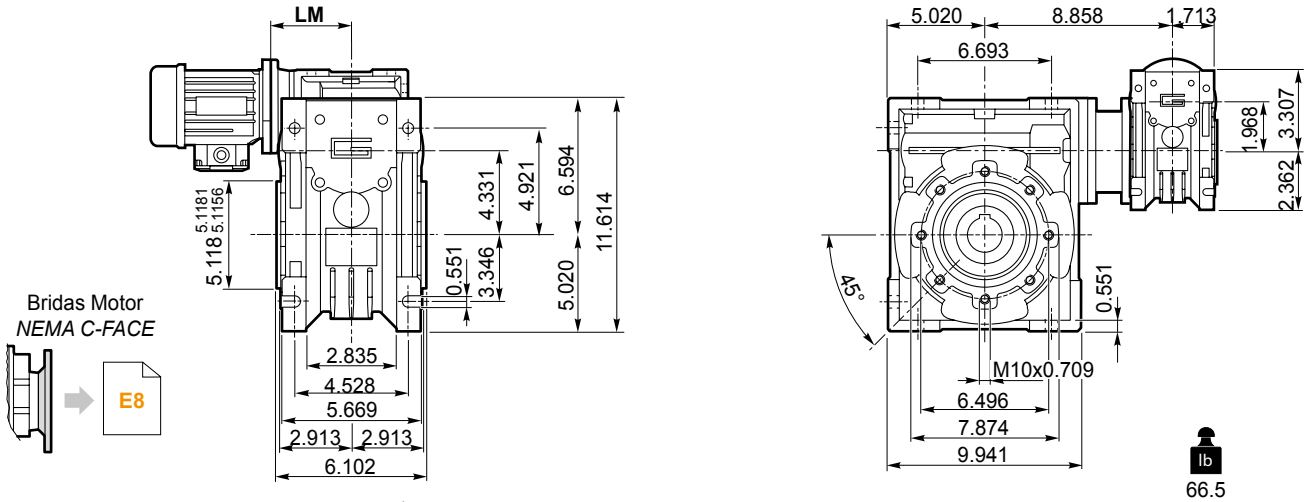

CMM 050/110 F

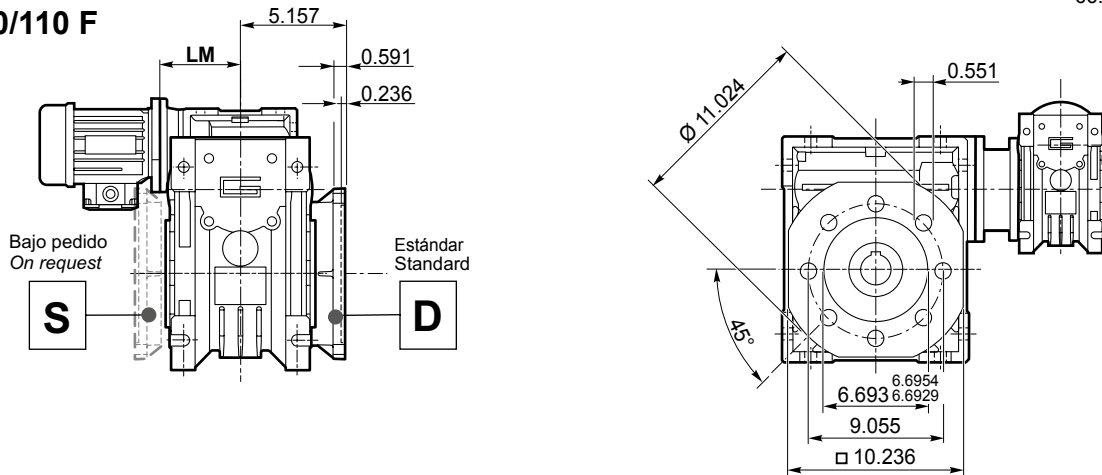

CMMIS 050/110 ..

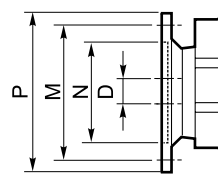
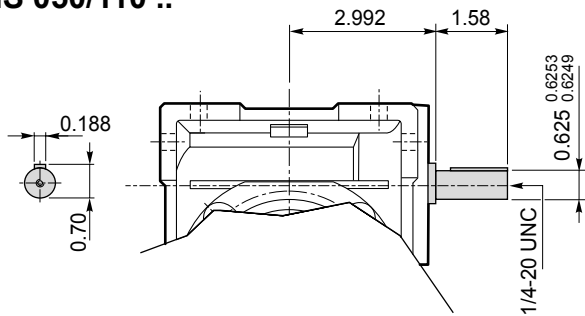

Brida Motor / Motor flange	
Dimensiones NEMA NEMA Dimensions	
	56 C
N	4.5
M	5.88
P	6.5
D	0.625
LM	3.346

Eje de salida hueco / Hollow output shaft

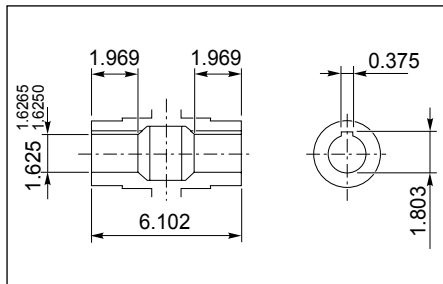

Eje de salida / Output shaft

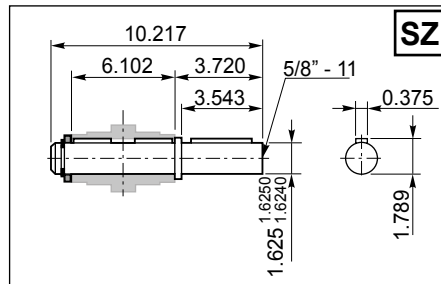

Eje de salida / Output shaft

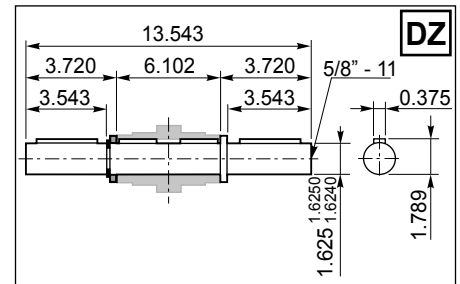

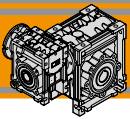

Dimensiones

Dimensions

CMM 063/130

CMM 063/130 U

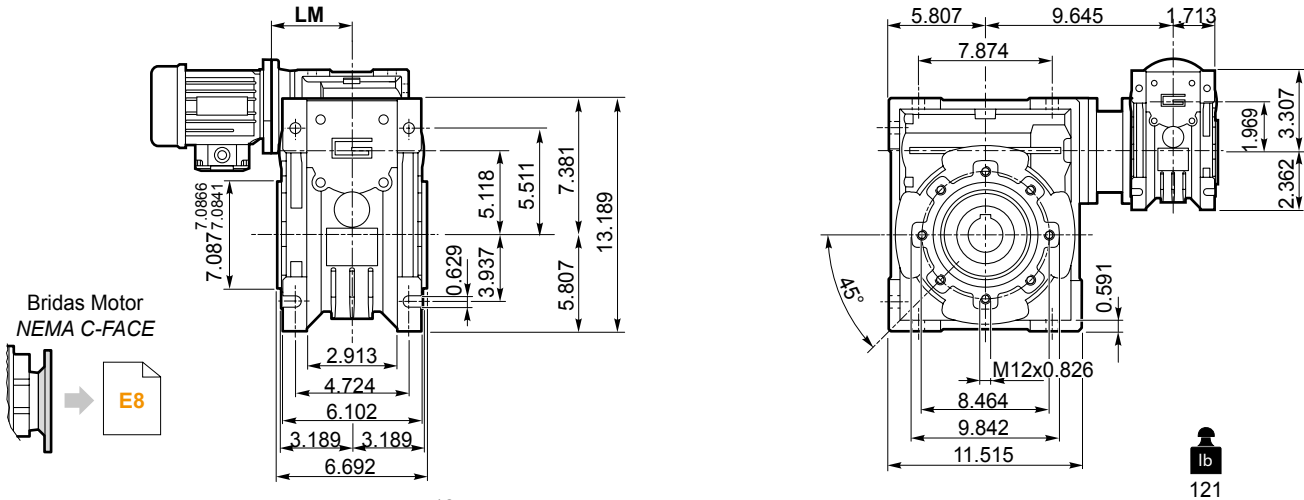

CMM 063/130 F

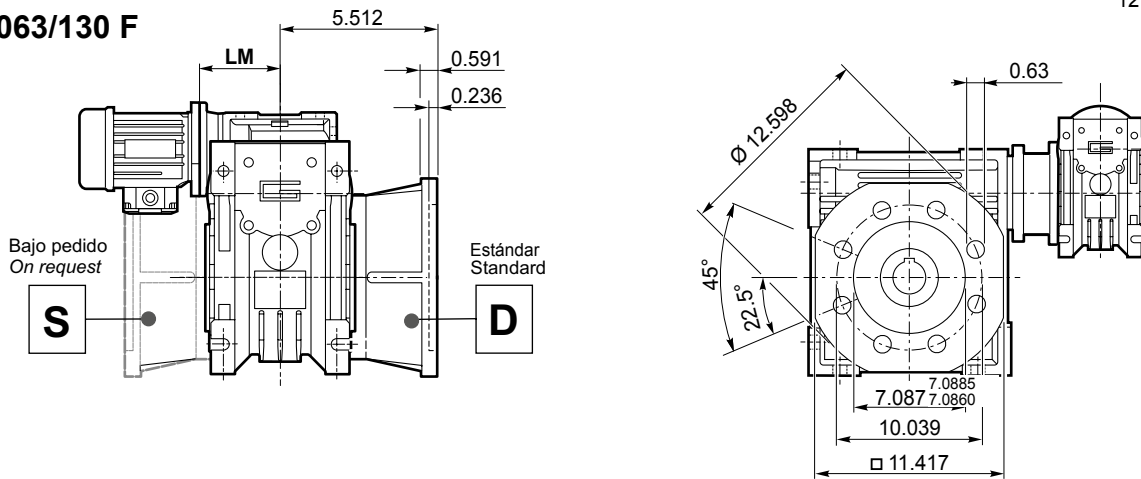

CMMIS 063/130 ..

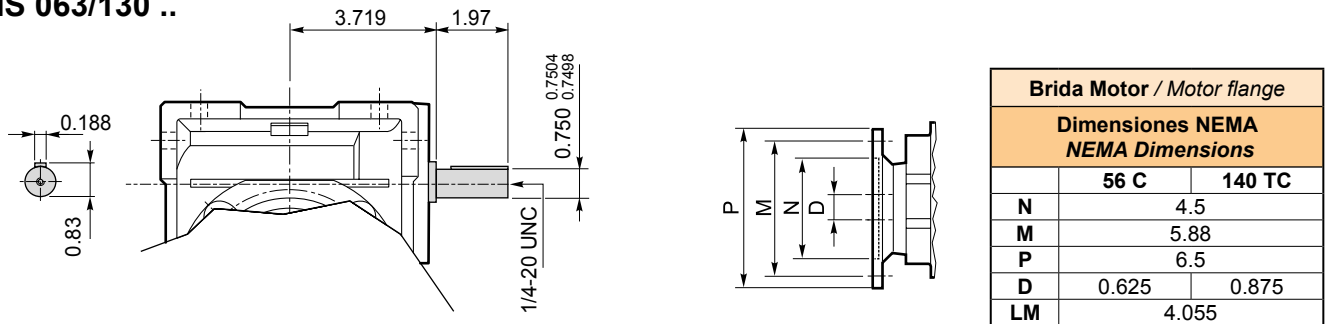

Eje de salida hueco / Hollow output shaft

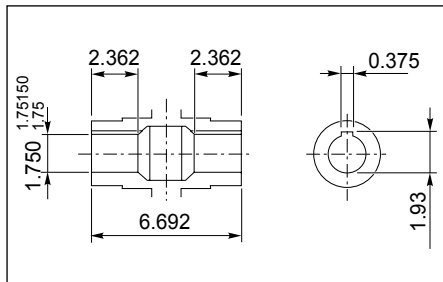

Eje de salida / Output shaft

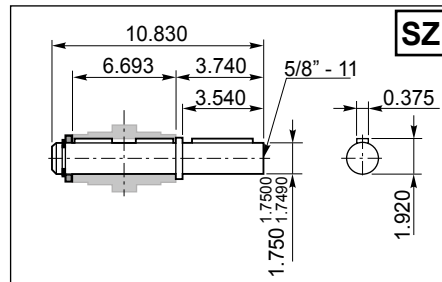

Eje de salida / Output shaft

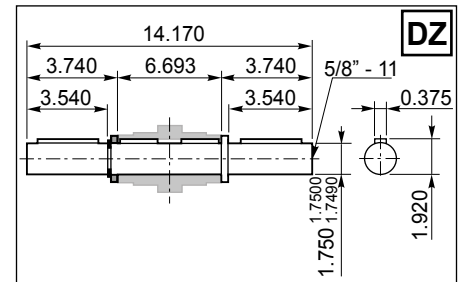

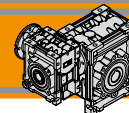

Accesorios

Accessories

Eje de salida simple y doble

Single and double output shaft

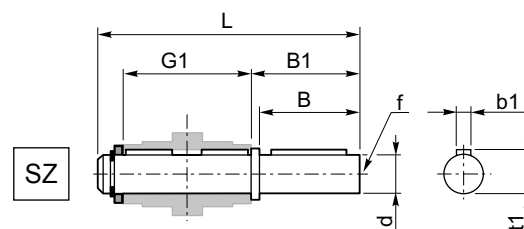
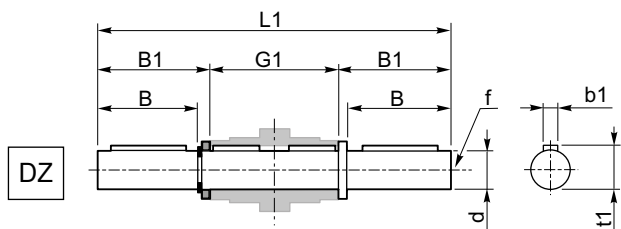

CMM	d	B	B1	G1	L	L1	f	b1	t1
040/075	1.250 <small>1.250 1.249</small>	2.756	2.894	4.724	7.933	10.512	1/2"-13	0.250	1.360
040/090	1.375 <small>1.375 1.3741</small>	3.150	3.327	5.512	9.232	12.165	1/2"-13	0.312	1.509
050/110	1.625 <small>1.625 1.624</small>	3.543	3.720	6.102	10.217	13.543	5/8"-11	0.375	1.789
063/130	1.750 <small>1.750 1.749</small>	3.540	3.740	6.693	10.830	14.170	5/8"-11	0.375	1.920

CMM

Brazo de reacción

Torque arm

CMM	K1	G	KG	KH	R
040/075	7.874	0.984	1.831	0.787	1.181
040/090	7.874	0.984	2.224	0.787	1.181
050/110	9.843	1.181	2.441	0.984	1.378
063/130	9.842	1.181	2.717	0.984	1.378

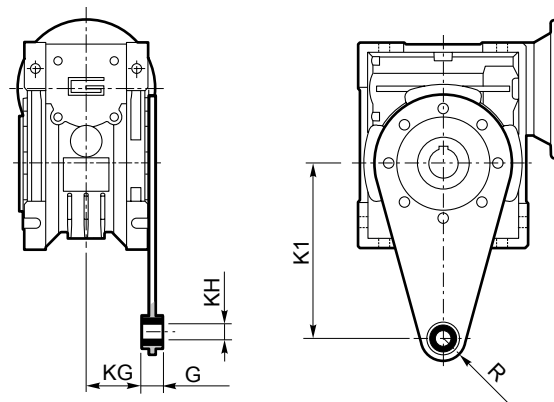

Opciones

Options

SC - Cubierta de seguridad / Safety Cover

CMM	M
040/075	3.110
040/090	3.701
050/110	4.016
063/130	4.606

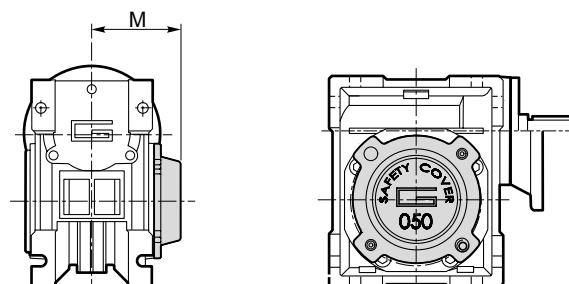

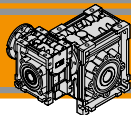
**CMM****REDUCTORES SINFIN Y CORONA DOBLE REDUCCION**
DOUBLE REDUCTION WORM-WORM GEARBOXES

Архангельск (8182)63-90-72
Астана (7172)727-132
Белгород (4722)40-23-64
Брянск (4832)59-03-52
Владивосток (423)249-28-31
Волгоград (844)278-03-48
Вологда (8172)26-41-59
Воронеж (473)204-51-73
Екатеринбург (343)384-55-89
Иваново (4932)77-34-06
Ижевск (3412)26-03-58
Казань (843)206-01-48

Калининград (4012)72-03-81
Калуга (4842)92-23-67
Кемерово (3842)65-04-62
Киров (8332)68-02-04
Краснодар (861)203-40-90
Красноярск (391)204-63-61
Курск (4712)77-13-04
Липецк (4742)52-20-81
Магнитогорск (3519)55-03-13
Москва (495)268-04-70
Мурманск (8152)59-64-93
Набережные Челны (8552)20-53-41

Нижний Новгород (831)429-08-12
Новокузнецк (3843)20-46-81
Новосибирск (383)227-86-73
Орел (4862)44-53-42
Оренбург (3532)37-68-04
Пенза (8412)22-31-16
Пермь (342)205-81-47
Ростов-на-Дону (863)308-18-15
Рязань (4912)46-61-64
Самара (846)206-03-16
Санкт-Петербург (812)309-46-40
Саратов (845)249-38-78

Смоленск (4812)29-41-54
Сочи (862)225-72-31
Ставрополь (8652)20-65-13
Тверь (4822)63-31-35
Томск (3822)98-41-53
Тула (4872)74-02-29
Тюмень (3452)66-21-18
Ульяновск (8422)24-23-59
Уфа (347)229-48-12
Челябинск (351)202-03-61
Череповец (8202)49-02-64
Ярославль (4852)69-52-93

Единый адрес для всех регионов: ton@nt-rt.ru || www.transtecno.nt-rt.ru