

ECFT

ECFT



Ferrite

Цилиндрические мотор-редукторы с параллельными валами

Руководство по эксплуатации



Архангельск (8182)63-90-72
Астана (7172)727-132
Белгород (4722)40-23-64
Брянск (4832)59-03-52
Владивосток (423)249-28-31
Волгоград (844)278-03-48
Вологда (8172)26-41-59
Воронеж (473)204-51-73
Екатеринбург (343)384-55-89
Иваново (4932)77-34-06
Ижевск (3412)26-03-58
Казань (843)206-01-48

Калининград (4012)72-03-81
Калуга (4842)92-23-67
Кемерово (3842)65-04-62
Киров (8332)68-02-04
Краснодар (861)203-40-90
Красноярск (391)204-63-61
Курск (4712)77-13-04
Липецк (4742)52-20-81
Магнитогорск (3519)55-03-13
Москва (495)268-04-70
Мурманск (8152)59-64-93
Набережные Челны (8552)20-53-41

Нижний Новгород (831)429-08-12
Новокузнецк (3843)20-46-81
Новосибирск (383)227-86-73
Орел (4862)44-53-42
Оренбург (3532)37-68-04
Пенза (8412)22-31-16
Пермь (342)205-81-47
Ростов-на-Дону (863)308-18-15
Рязань (4912)46-61-64
Самара (846)206-03-16
Санкт-Петербург (812)309-46-40
Саратов (845)249-38-78

Смоленск (4812)29-41-54
Сочи (862)225-72-31
Ставрополь (8652)20-65-13
Тверь (4822)63-31-35
Томск (3822)98-41-53
Тула (4872)74-02-29
Тюмень (3452)66-21-18
Ульяновск (8422)24-23-59
Уфа (347)229-48-12
Челябинск (351)202-03-61
Череповец (8202)49-02-64
Ярославль (4852)69-52-93

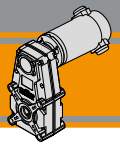

Indice	Index	Pag. Page
Caratteristiche tecniche	<i>Technical features</i>	M2
Designazione	<i>Classification</i>	M2
Sensi di rotazione	<i>Direction of rotation</i>	M3
Simbologia	<i>Symbols</i>	M3
Lubrificazione	<i>Lubrication</i>	M3
Carichi radiali	<i>Radial loads</i>	M4
Dati tecnici	<i>Technical data</i>	M5
Motori applicabili	<i>Motor adapters</i>	M6
Dimensioni	<i>Dimensions</i>	M7

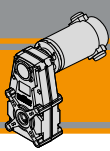

Caratteristiche tecniche

Technical features

I motoriduttori CC pendolari a magneti permanenti in ferrite ECFT hanno le seguenti caratteristiche principali:

ECFT ferrite permanent magnets DC helical parallel gearmotors range has the following main features:

- Alimentazione in bassa tensione 12/24 Vcc
- Possibilità di montaggio encoder
- Potenze motore disponibili da 100 a 800W S2
- Magneti in ferrite
- Carcasa pressofusione di alluminio
- Lubrificazione permanente con olio sintetico.
- Ingranaggi cilindrici a denti elicoidali.

- Low voltage power supply 12/24 Vdc
- Suitable for encoder assembly
- Motor power ratings available from 100 to 800W S2
- Ferrite magnets
- Die-cast aluminum housings
- Permanent synthetic oil long-life lubrication.
- helical gears.

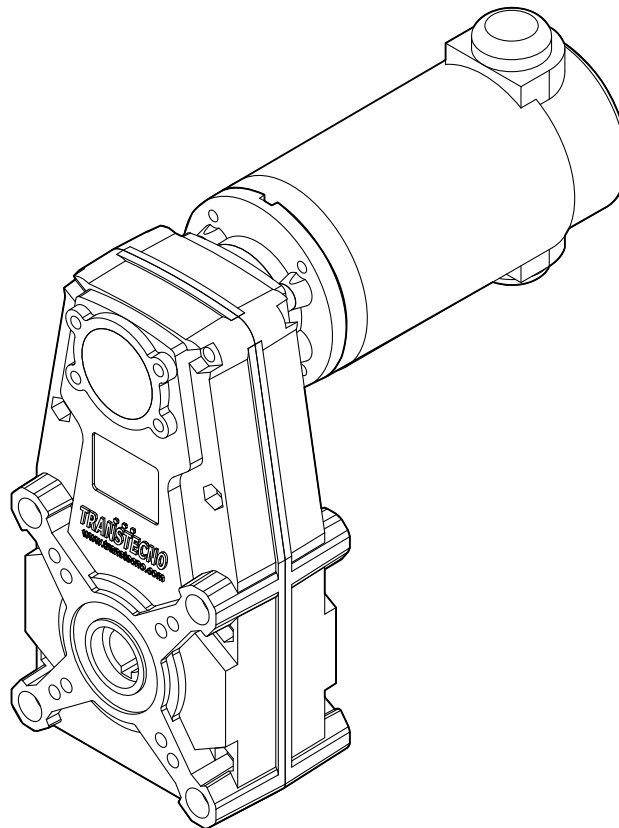

Designazione

Classification

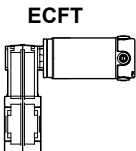
MOTORIDUTTORE / GEARMOTORS							U	60.63	O20	B5
ECFT	180/146						U	60.63	O20	B5
Tipo Type	Grandezza Size						Versione Version	Rapporto Ratio	Albero cavo uscita Hollow output shaft	Versione motore Motor version
	070/105/3	100/105/3	180/105/3	250/146	350/146	600/196	U...	vedi tabelle see tables	vedi tabelle see tables	120 240 12E 24E
	070/105/4	100/146	180/146	250/196	350/196					
	070/146									

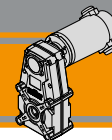

Sensi di rotazione

Direction of rotation

FT105/3
FT146
FT196

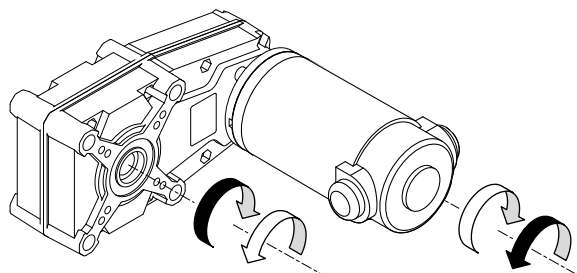
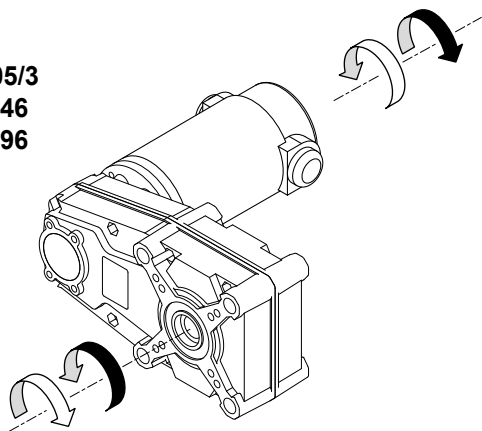

FT105/4

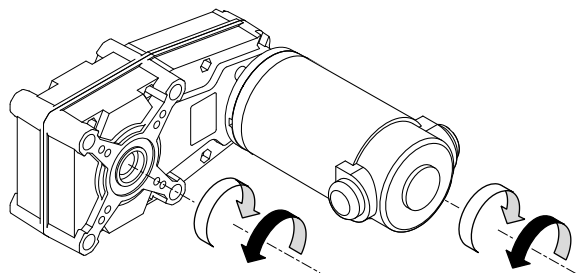
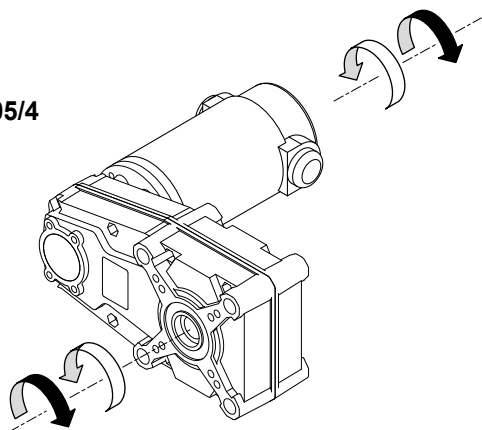

ECFT

Simbologia

Symbols

n_1	[min^{-1}]	Velocità in ingresso / <i>Input speed</i>
n_2	[min^{-1}]	Velocità in uscita / <i>Output speed</i>
i		Rapporto di riduzione / <i>Ratio</i>
P_1	[kW]	Potenza in entrata / <i>Input power</i>
M_2	[Nm]	Coppia nominale in uscita in funzione di P_1 / <i>Output torque referred to P_1</i>
P_{n1}	[kW]	Potenza nominale in entrata / <i>Nominal input power</i>
M_{n2}	[Nm]	Coppia nominale in uscita in funzione di P_{n1} / <i>Nominal output torque referred to P_{n1}</i>
sf		Fattore di servizio / <i>Service factor</i>
R_2	[N]	Carico radiale ammissibile in uscita / <i>Permitted output radial load</i>
A_2	[N]	Carico assiale ammissibile in uscita / <i>Permitted output axial load</i>

Lubrificazione

Lubrication

Tutti i motoriduttori sono forniti completi di lubrificante sintetico viscosità 320, pertanto possono essere installati in qualunque posizione di montaggio e non necessitano di manutenzione.

Permanent synthetic oil long-life lubrication (viscosity grade 320) makes it possible to use the gearmotors in all mounting positions; for this reason they can be installed in any assembly position and do not require maintenance.



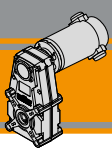

Carichi radiali

Radial loads

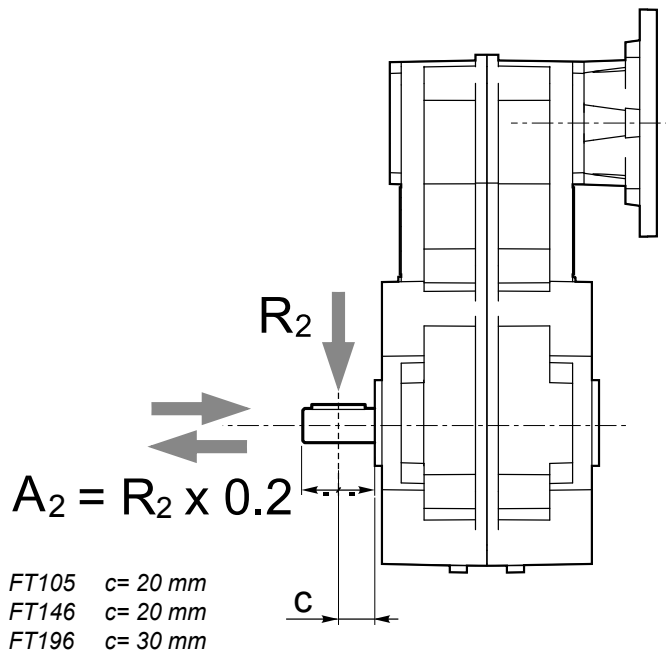

n ₂ [min ⁻¹]	R ₂ [N]		
	FT105	FT146	FT196
70	1500	2500	3500
40	1700	2700	4000
30	1850	2850	4600
20	2000	3000	5500
10	2000	3000	7000
5	2000	3000	7000

Quando il carico radiale risultante non è applicato sulla mezza-
ria dell'albero occorre calcolare quello effettivo con la seguente
formula:

When the resulting radial load is not applied on the centre line
of the shaft it is necessary to calculate the effective load with the
following formula:

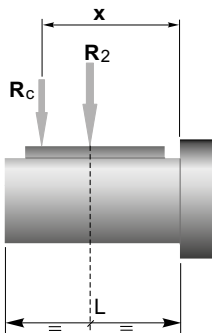

	FT105	FT146	FT196
a	82	82,5	132
b	62	62,5	102
R _{2MAX}	2000	3000	7000

$$R_c = \frac{R_2 \cdot a}{(b+x)} \leq R_{2MAX}$$

$$R \leq R_c$$

a, b = valori riportati nella tabella
a, b = values given in the table

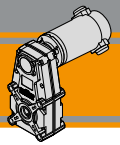

Dati tecnici

Technical data

P ₁ [W]	n ₂ [min ⁻¹]	M ₂ [Nm]	sf	i		Versione motore Motor version	P ₁ [W]	n ₂ [min ⁻¹]	M ₂ [Nm]	sf	i		Versione motore Motor version				
100							250										
(3000 min ⁻¹)	146	6	5.1	20.57	070/105/3	12E/24E	(3000 min ⁻¹)	146	15	2.0	20.57	180/105/3	120/240				
	90	10	3.9	33.32				90	25	1.6	33.32						
	68	13	3.8	44.36				68	33	1.5	44.36						
	55	16	3.1	54.87				55	41	1.2	54.87						
	42	21	2.4	71.84				42	54	0.9	71.84						
	39	23	2.2	77.07				39	58	0.9	77.07						
	34	27	1.9	88.87				34	66	0.8	88.87						
	24	37	1.4	124.81													
	17	54	0.9	181.35				49	45	1.9	60.63			180/146	120/240/24E		
	13	67	0.8	224.32				35	63	1.4	84.63						
	9.5	86	0.6	315.05		31	72	1.2	95.61								
						26	85	1.0	113.40								
	11	78	0.6	262.16	070/105/4	12E/24E	22	100	0.9	133.45							
	8.1	94	0.5	368.19				20	112	0.8	150.18						
	5.6	94	0.5	534.98				19	120	0.8	160.43						
	4.5	94	0.5	661.76													
	3.2	94	0.5	929.40													
	49	18	4.7	60.63	070/146	12E/24E	350										
	35	25	3.4	84.63			(3000 min ⁻¹)	49	64	1.4	60.63	250/146	120/240				
	31	29	3.0	95.61				35	89	1.0	84.63						
	26	34	2.5	113.40				31	100	0.9	95.61						
	22	40	2.1	133.45				26	119	0.7	113.40						
	20	45	1.9	150.18								250/196	120/240				
	19	48	1.9	160.43				147	21	12.8	20.41						
	17	54	1.7	178.83				70	45	7.9	42.61						
	13	67	1.4	223.92				51	62	6.3	59.36						
	13	71	1.3	236.83				32	97	4.4	92.82						
	10	90	1.0	300.07				24	130	3.3	123.95						
	7.5	119	0.8	397.38				15	211	2.0	201.80						
								11	282	1.5	269.47						
140							500										
(3000 min ⁻¹)	146	9	3.6	20.57	100/105/3	120/240/24E	(3000 min ⁻¹)	49	91	0.9	60.63	350/146	120/240				
	90	14	2.8	33.32				147	31	8.9	20.41			350/196	120/240		
	68	19	2.7	44.36				70	64	5.5	42.61						
	55	23	2.2	54.87				51	89	4.4	59.36						
	42	30	1.7	71.84				32	139	3.1	92.82						
	39	32	1.6	77.07				24	185	2.3	123.95						
	34	37	1.4	88.87				15	302	1.4	201.80						
	24	52	1.0	124.81				11	403	1.1	269.47						
	49	25	3.4	60.63			100/146	120/240/24E	800								
	35	35	2.4	84.63					(3000 min ⁻¹)	147	49	5.6	20.41			600/196	120/240
	31	40	2.1	95.61						70	102	3.4	42.61				
	26	48	1.8	113.40						51	142	2.7	59.36				
	22	56	1.5	133.45						32	222	1.9	92.82				
	20	63	1.4	150.18		24			297	1.4	123.95						
	19	67	1.4	160.43		15			483	0.9	201.80						
	17	75	1.2	178.83													
	13	94	1.0	223.92													
	13	99	0.9	236.83													
	10	126	0.7	300.07													

N.B.
Verificare sempre che la coppia M2 utilizzata non ecceda il valore indicato nelle caselle in grigio

N.B.
Please check that the output torque M2 does not exceed the value in the grey areas

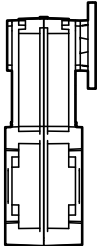
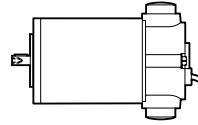
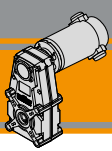

		EC						
		070.12E 070.24E	100.120 100.240 100.24E	180.120 180.240	180.24E	250.120 250.240	350.120 350.240	600.120 600.240
FT	105/3	20.57 - 315.05	20.57 - 315.05	20.57 - 315.05				
	105/4	262.16 - 929.4						
	146	60.63 - 397.38	60.63 - 397.38	60.63 - 397.38	60.63 - 397.38	60.63 - 397.38	60.63 - 397.38	
	196					20.41 - 269.47	20.41 - 269.47	20.41 - 269.47

20.57 - 315.05

Rapporti di riduzione *i*
Ratio *i*

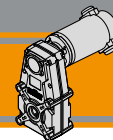

Dimensioni

Dimensions

ECFT 070/105

ECFT 070/105...U

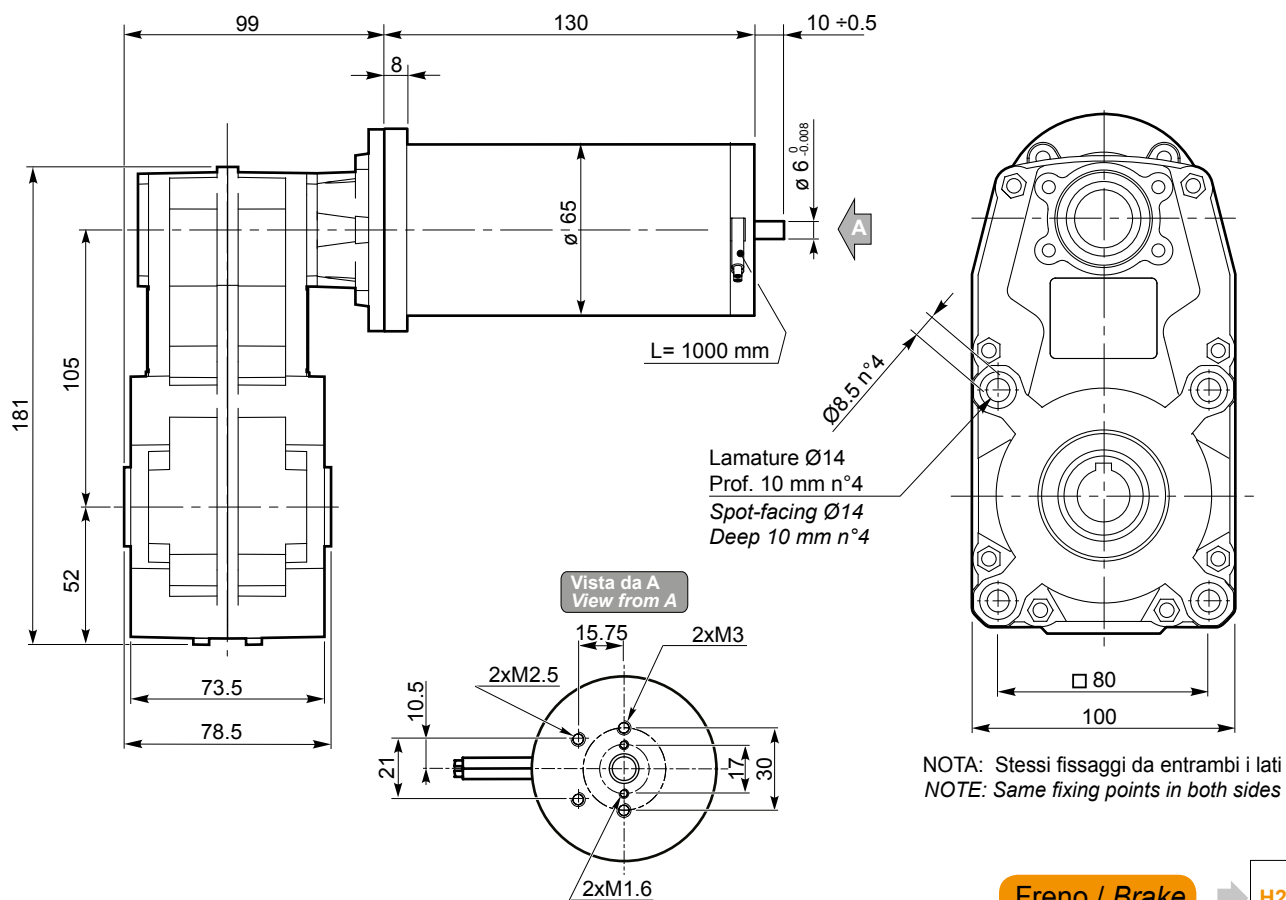

- Freno / Brake → H23
- Encoder → H24

O17

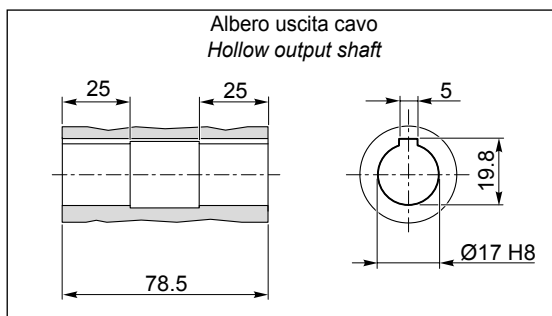

O20

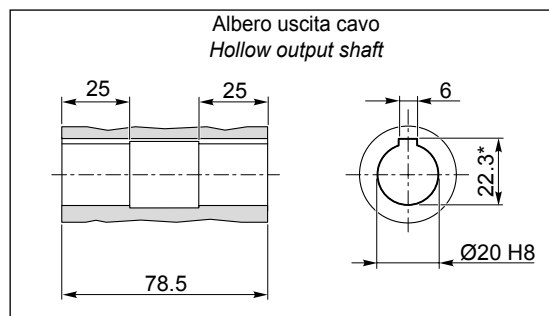

*: Sede linguetta ribassata / Special keyway

ECFT

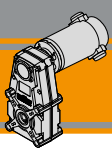

ECFT 100/105

ECFT 100/105...U

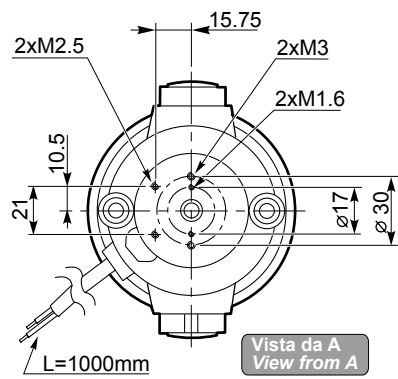
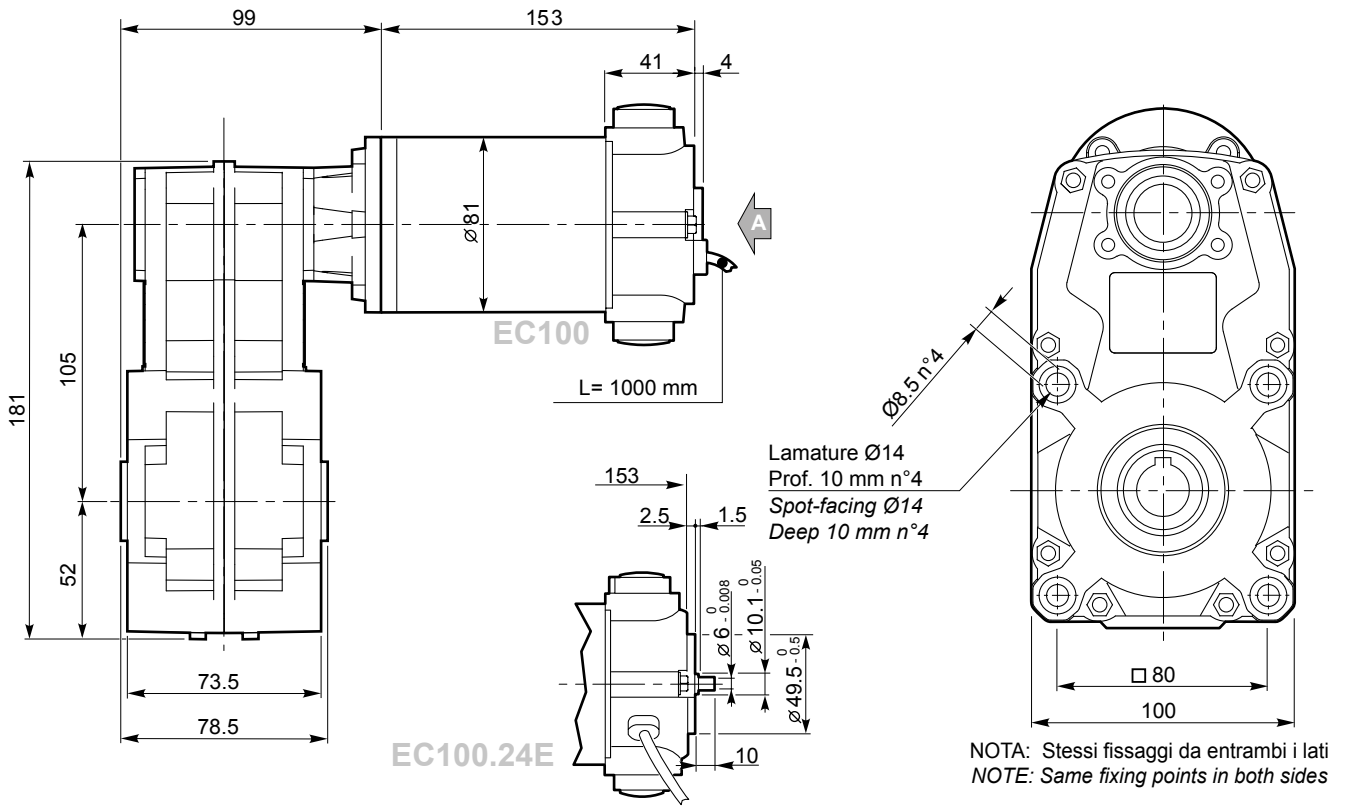

- Freno / Brake → H23
- Encoder → H24

O17

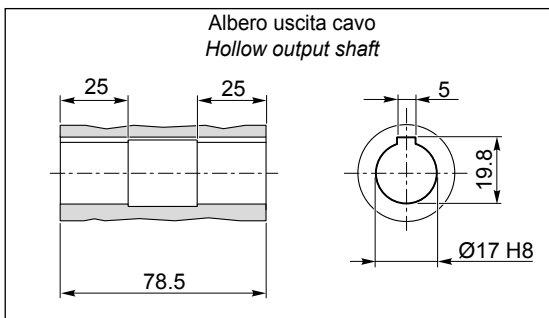

O20

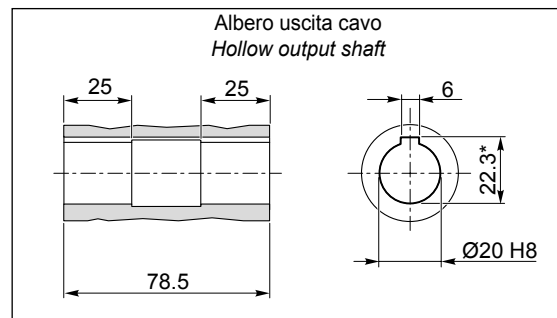

*: Sede linguetta ribassata / Special keyway

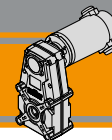

Dimensioni

Dimensions

ECFT 180/105

ECFT 180/105...U

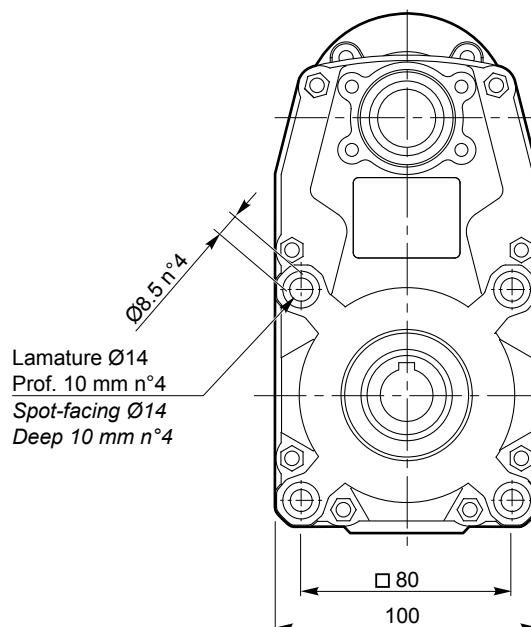
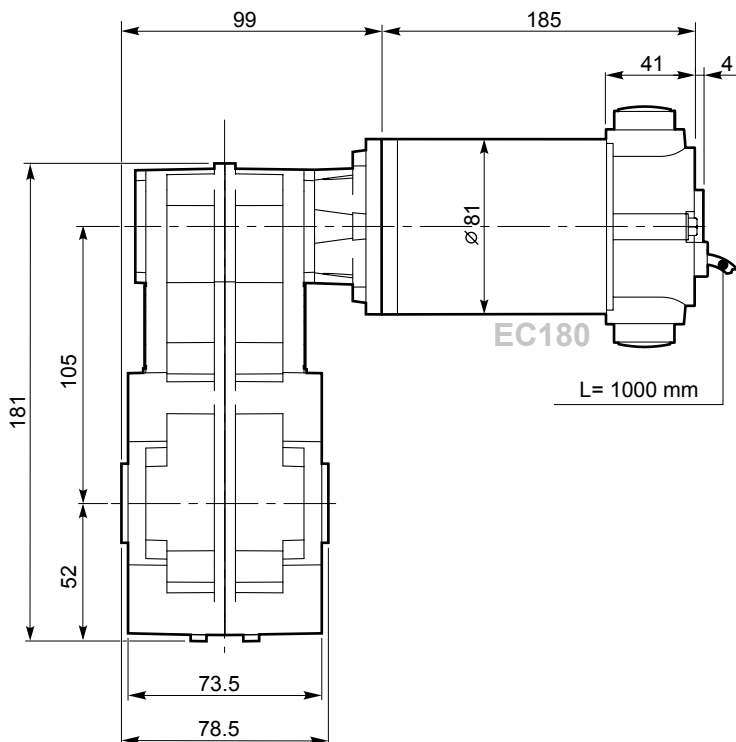

NOTA: Stessi fissaggi da entrambi i lati
NOTE: Same fixing points in both sides

O17

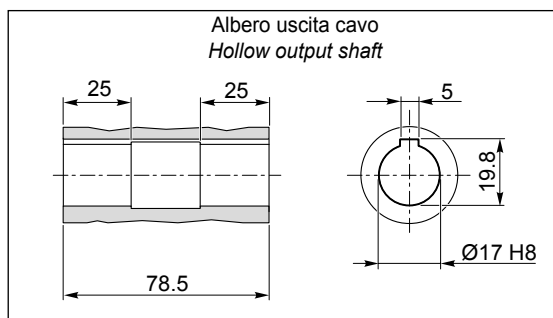

O20

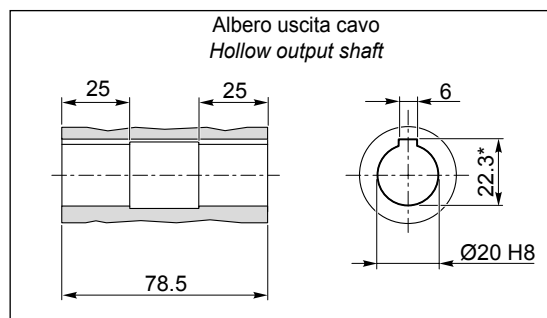

*: Sede linguetta ribassata / Special keyway

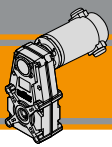

ECFT 070/146

ECFT 070/146 U

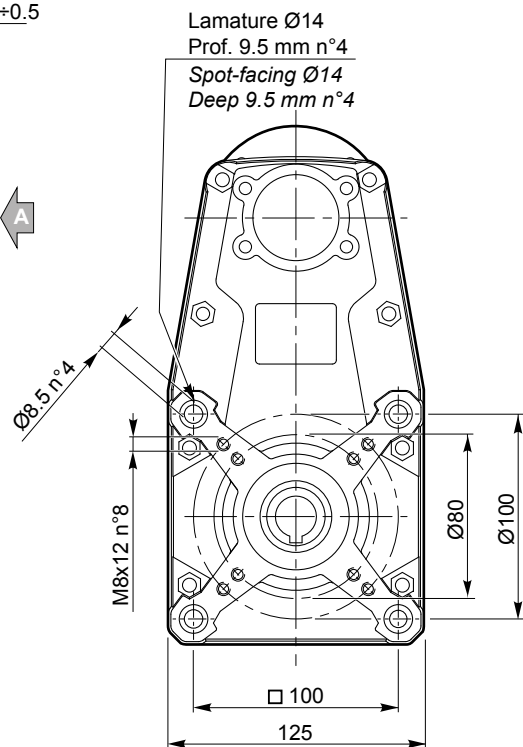
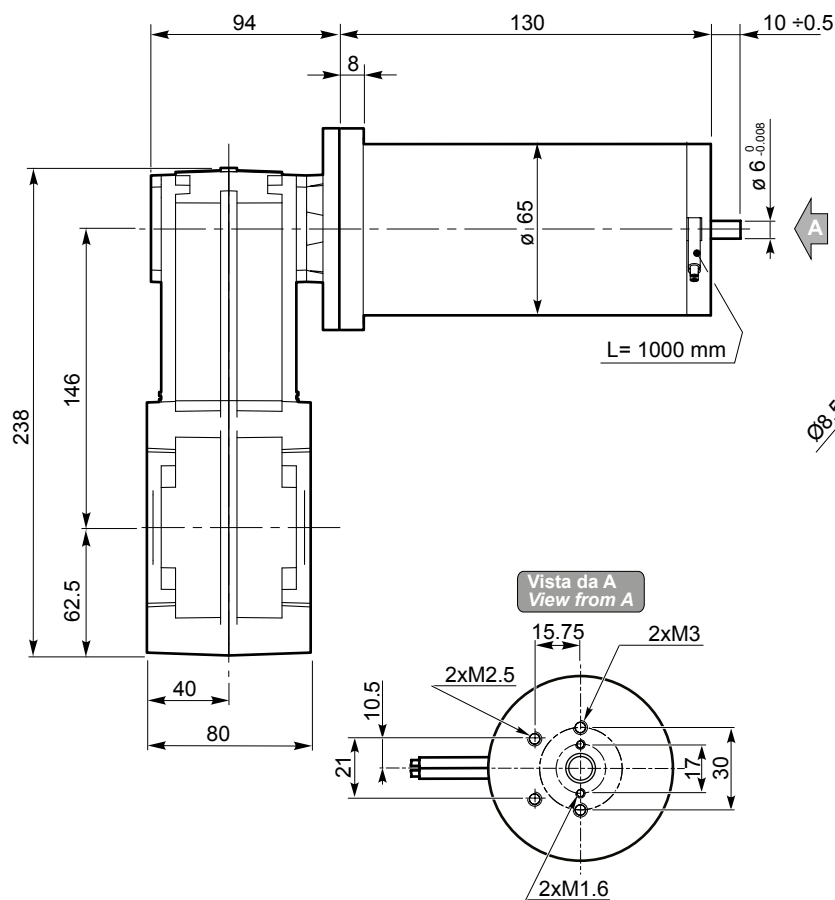

NOTA: Stessi fissaggi da entrambi i lati
NOTE: Same fixing points in both sides

- Freno / Brake → H23
- Encoder → H24

O20

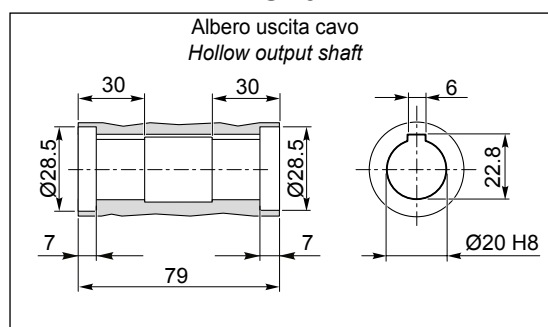

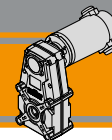

Dimensioni

Dimensions

ECFT 100/146

ECFT 100/146 U

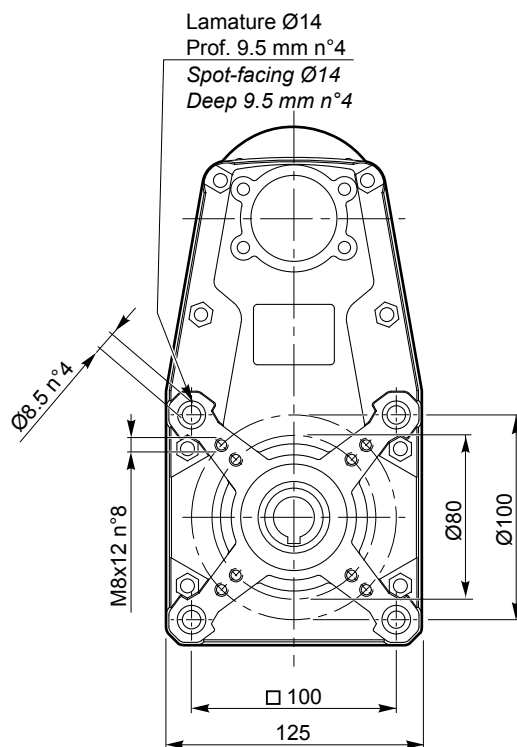
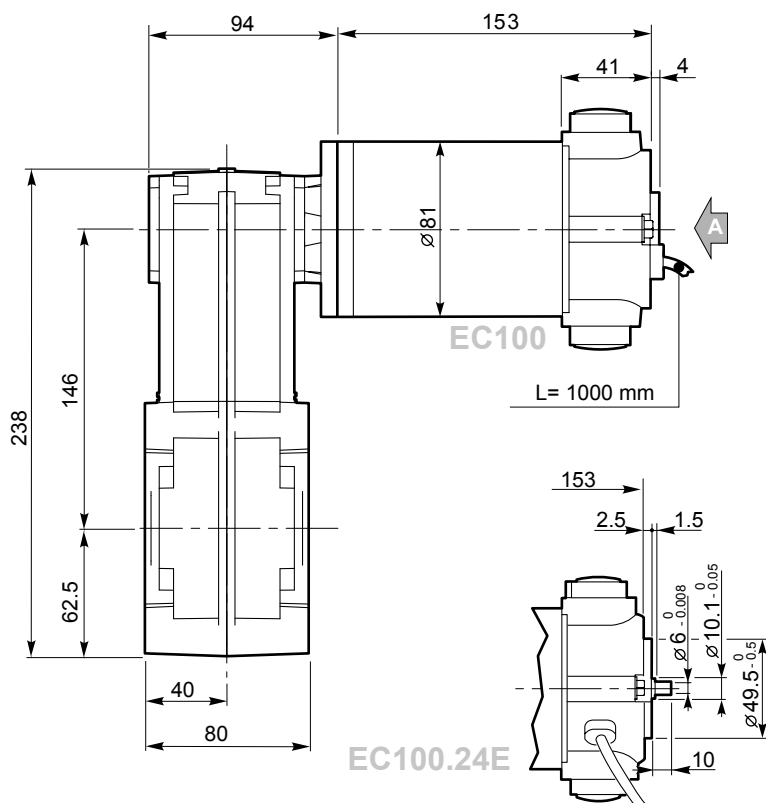

NOTA: Stessi fissaggi da entrambi i lati
NOTE: Same fixing points in both sides

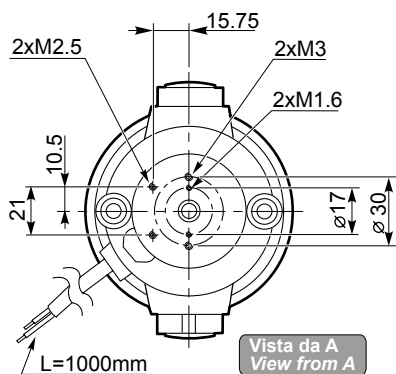

- Freno / Brake → H23
- Encoder → H24

ECFT

O20

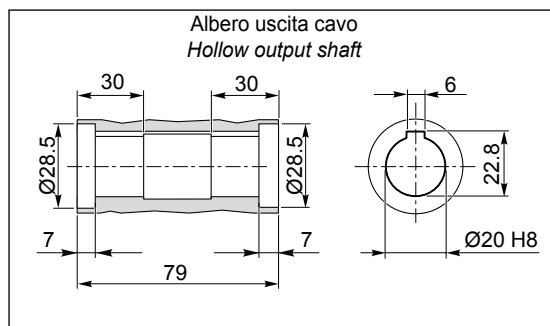

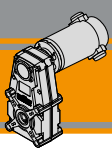

ECFT 180/146

ECFT 180/146 U

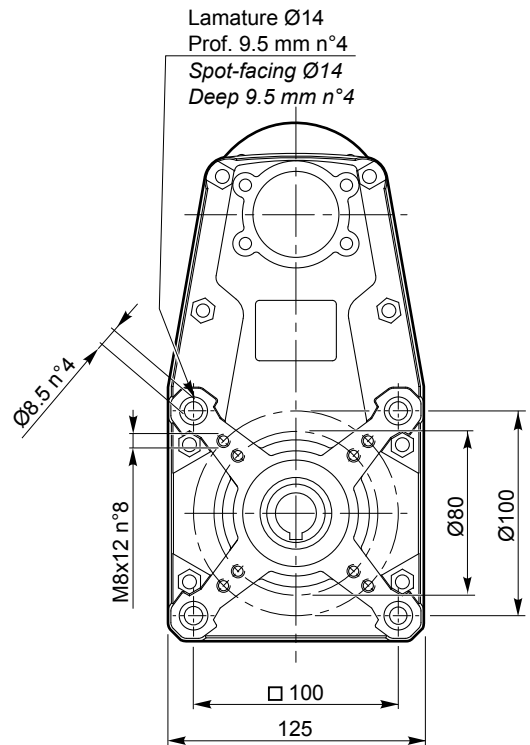
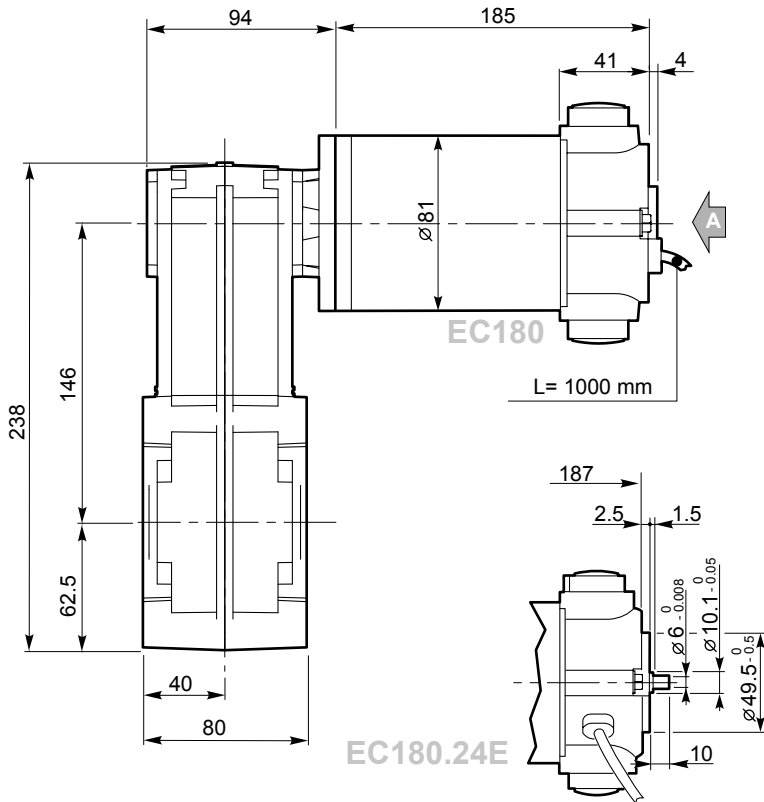

NOTA: Stessi fissaggi da entrambi i lati
NOTE: Same fixing points in both sides

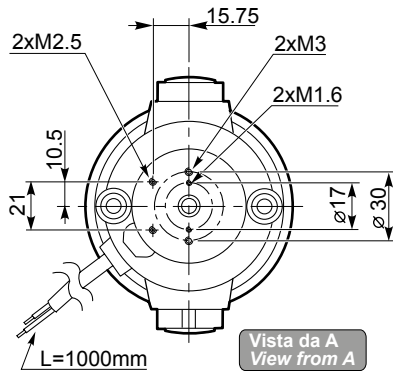

Freno / Brake

H23

Encoder

H24

O20

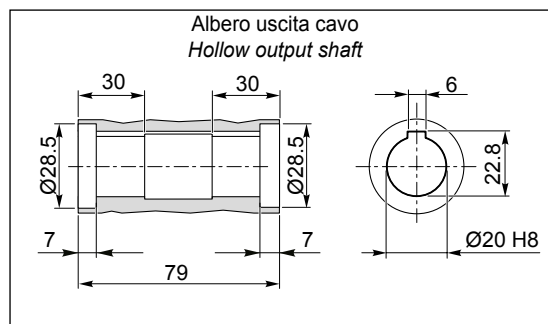

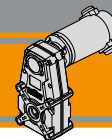

Dimensioni

Dimensions

ECFT 250/146

ECFT 250/146 U

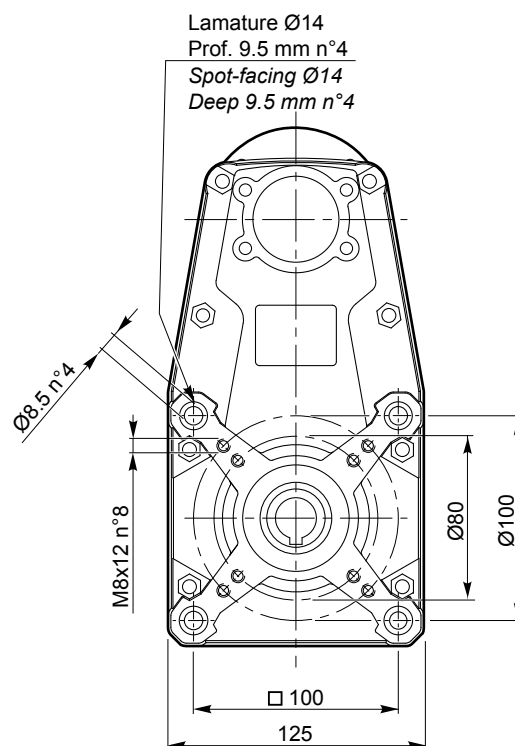
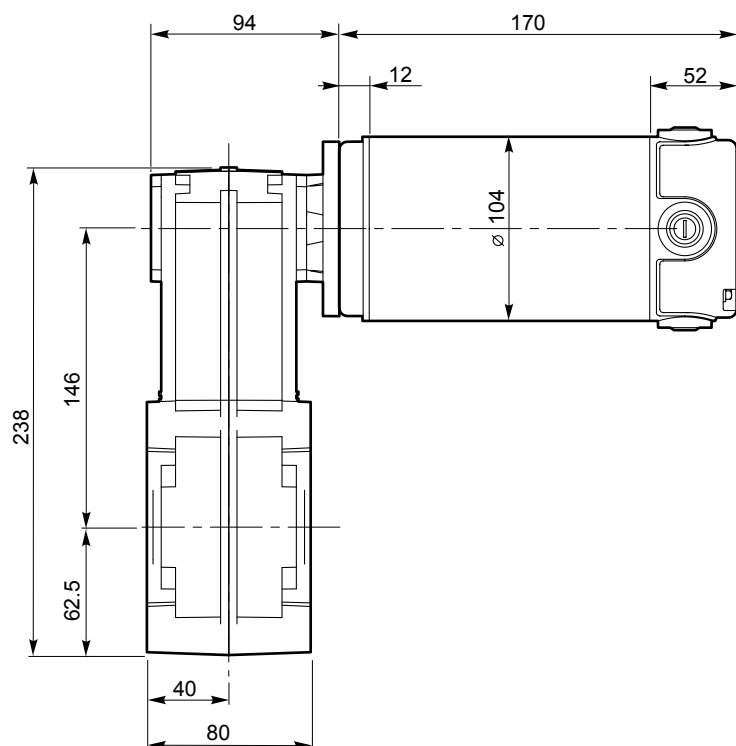

NOTA: Stessi fissaggi da entrambi i lati
NOTE: Same fixing points in both sides

O20

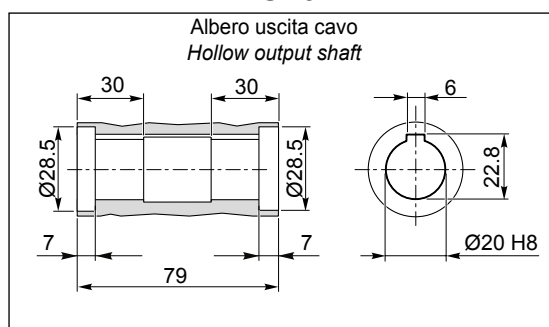

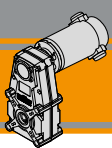

Dimensioni

Dimensions

ECFT 350/146

ECFT 350/146 U

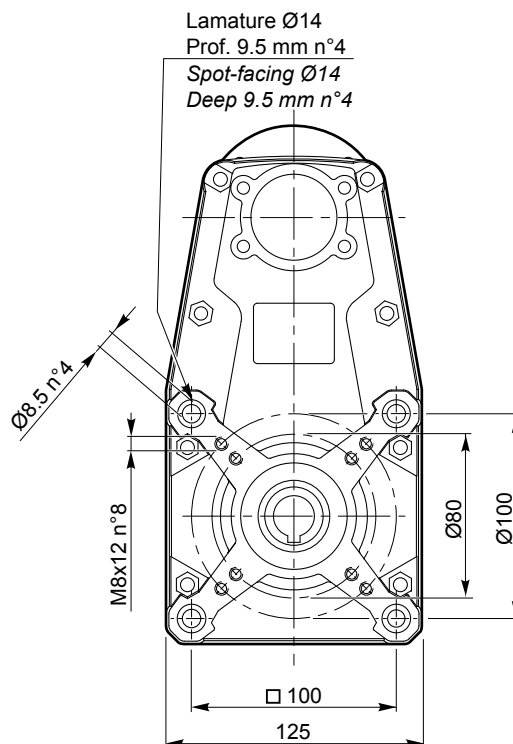
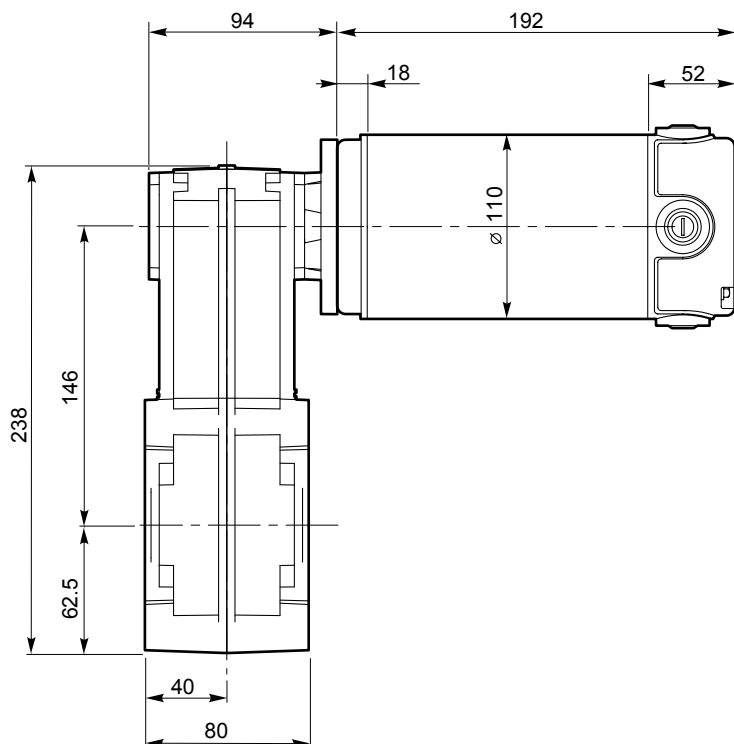

NOTA: Stessi fissaggi da entrambi i lati
NOTE: Same fixing points in both sides

Freno / Brake

H23

O20

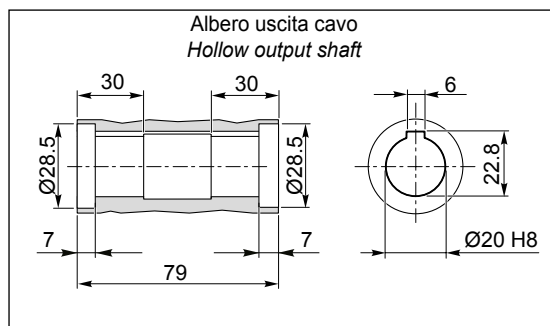

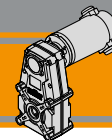

Dimensioni

Dimensions

ECFT 250/196

ECFT 250/196 U

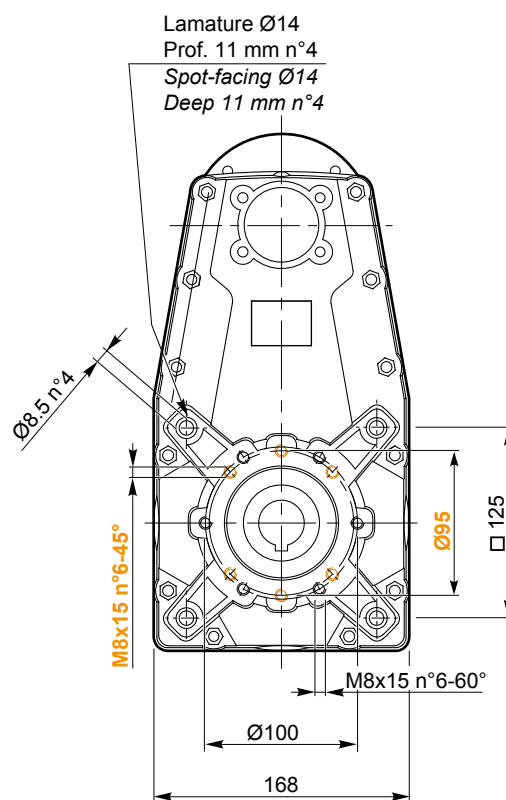
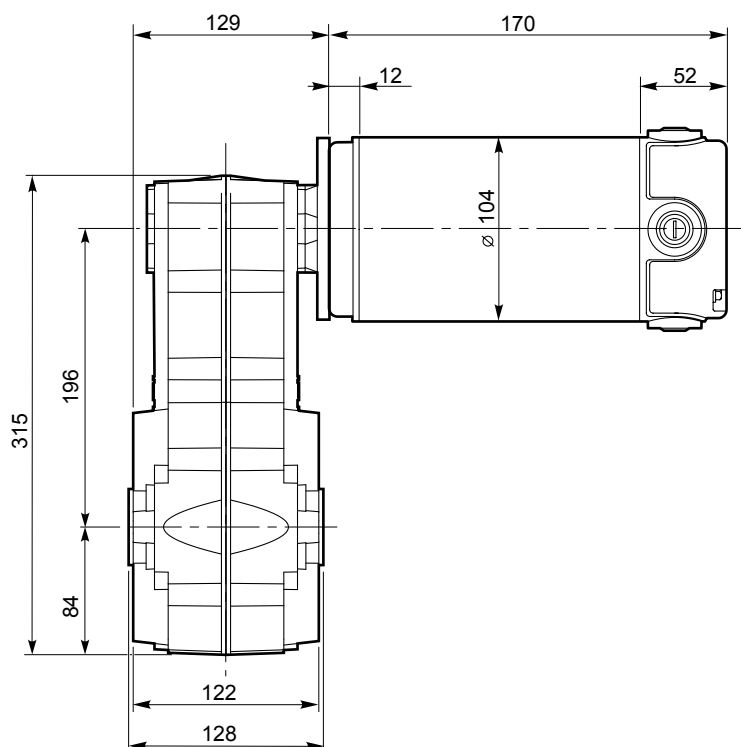

NOTA: Stessi fissaggi da entrambi i lati
NOTE: Same fixing points in both sides

O30

Albero uscita cavo
Hollow output shaft

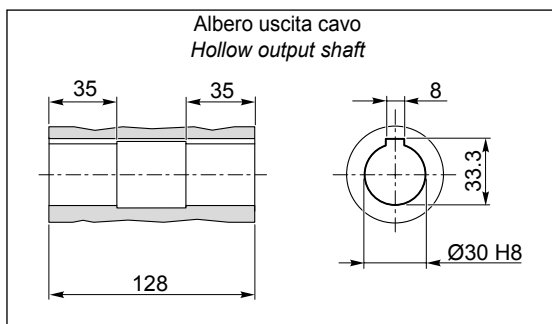

O35

Albero uscita cavo
Hollow output shaft

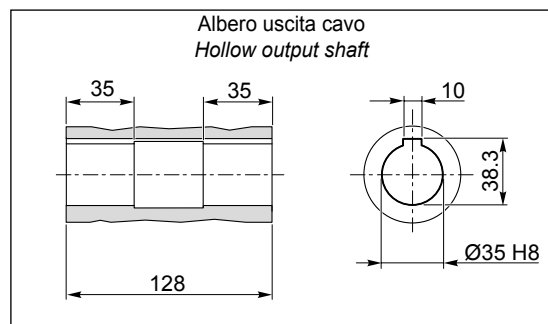

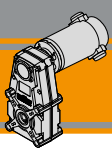

ECFT 350/196

ECFT 350/196 U

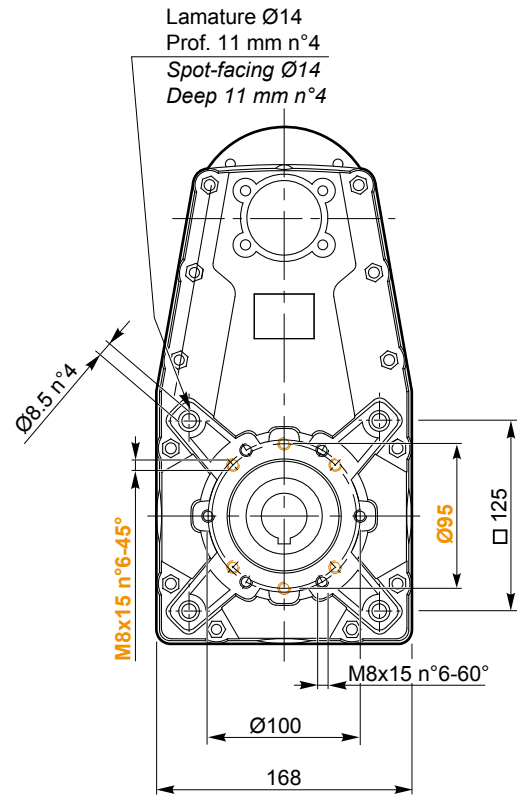
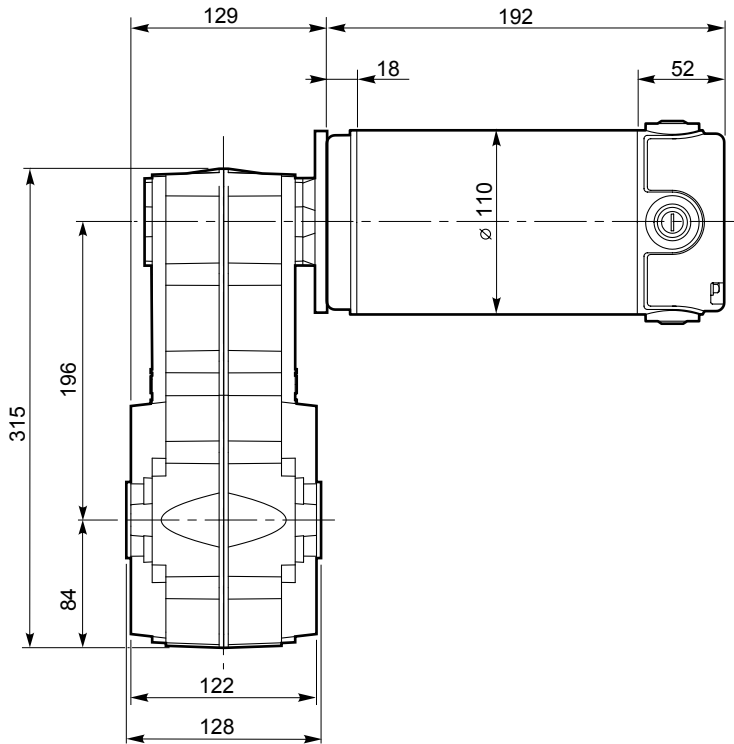

NOTA: Stessi fissaggi da entrambi i lati
NOTE: Same fixing points in both sides

Freno / Brake

H23

O30

Albero uscita cavo
Hollow output shaft

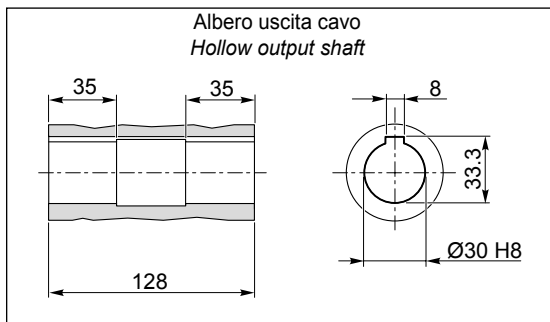

O35

Albero uscita cavo
Hollow output shaft

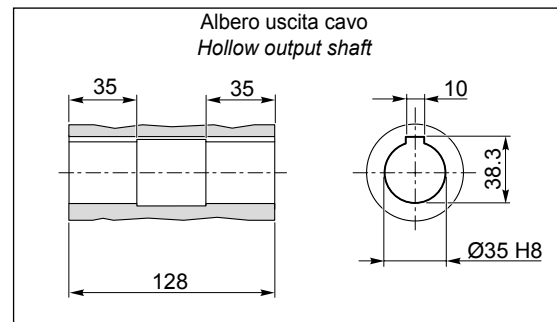

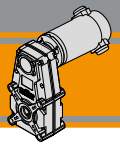

Dimensioni

Dimensions

ECFT 600/196

ECFT 600/196 U

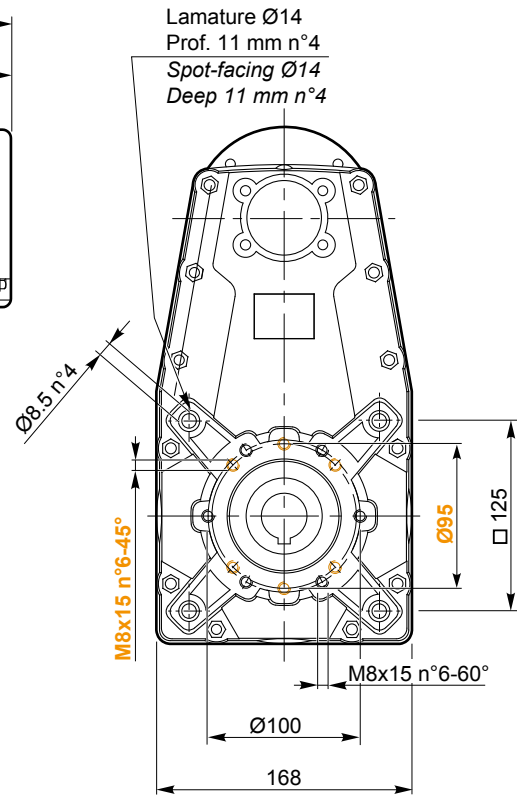
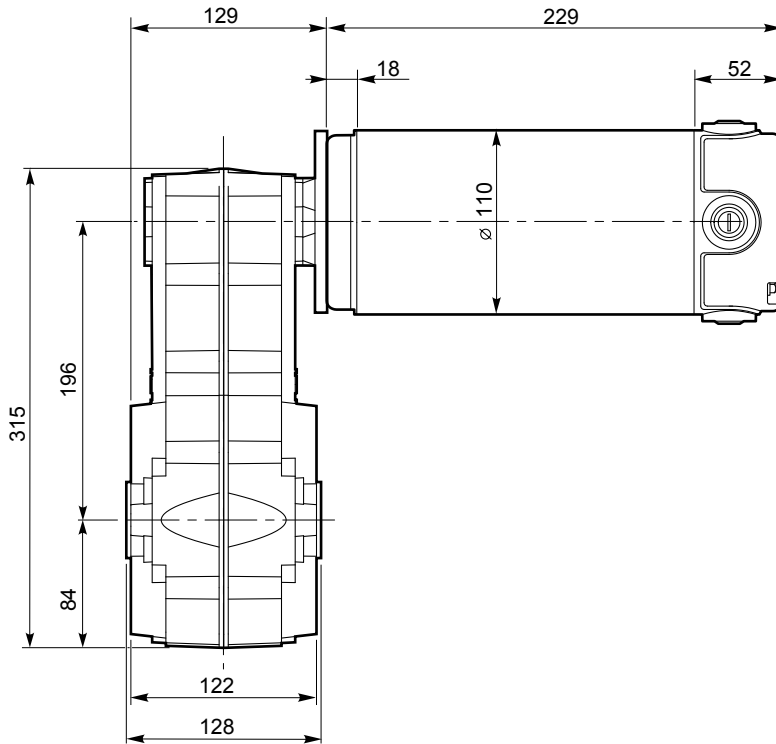

NOTA: Stessi fissaggi da entrambi i lati
NOTE: Same fixing points in both sides

Freno / Brake

H23

ECFT

O30

Albero uscita cavo
Hollow output shaft

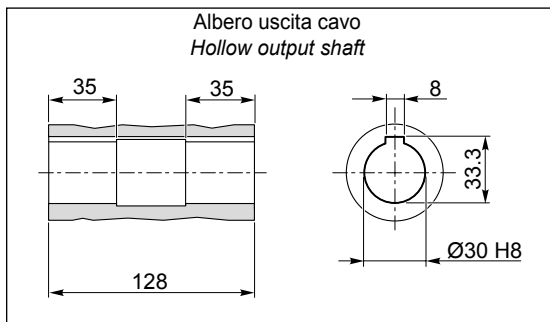

O35

Albero uscita cavo
Hollow output shaft

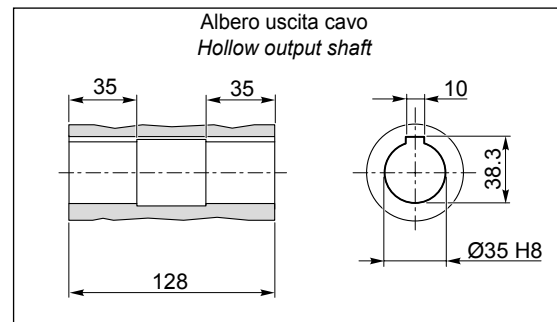

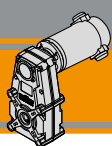
**ECFT****Motoriduttori CC pendolari
DC Helical parallel gearmotors**

Архангельск (8182)63-90-72
Астана (7172)727-132
Белгород (4722)40-23-64
Брянск (4832)59-03-52
Владивосток (423)249-28-31
Волгоград (844)278-03-48
Вологда (8172)26-41-59
Воронеж (473)204-51-73
Екатеринбург (343)384-55-89
Иваново (4932)77-34-06
Ижевск (3412)26-03-58
Казань (843)206-01-48

Калининград (4012)72-03-81
Калуга (4842)92-23-67
Кемерово (3842)65-04-62
Киров (8332)68-02-04
Краснодар (861)203-40-90
Красноярск (391)204-63-61
Курск (4712)77-13-04
Липецк (4742)52-20-81
Магнитогорск (3519)55-03-13
Москва (495)268-04-70
Мурманск (8152)59-64-93
Набережные Челны (8552)20-53-41

Нижний Новгород (831)429-08-12
Новокузнецк (3843)20-46-81
Новосибирск (383)227-86-73
Орел (4862)44-53-42
Оренбург (3532)37-68-04
Пенза (8412)22-31-16
Пермь (342)205-81-47
Ростов-на-Дону (863)308-18-15
Рязань (4912)46-61-64
Самара (846)206-03-16
Санкт-Петербург (812)309-46-40
Саратов (845)249-38-78

Смоленск (4812)29-41-54
Сочи (862)225-72-31
Ставрополь (8652)20-65-13
Тверь (4822)63-31-35
Томск (3822)98-41-53
Тула (4872)74-02-29
Тюмень (3452)66-21-18
Ульяновск (8422)24-23-59
Уфа (347)229-48-12
Челябинск (351)202-03-61
Череповец (8202)49-02-64
Ярославль (4852)69-52-93

Единый адрес для всех регионов: ton@nt-rt.ru || www.transtecno.nt-rt.ru