

ECM

ECM



Ferrite

Червячные мотор-редукторы Руководство по эксплуатации



Архангельск (8182)63-90-72
Астана (7172)727-132
Белгород (4722)40-23-64
Брянск (4832)59-03-52
Владивосток (423)249-28-31
Волгоград (844)278-03-48
Вологда (8172)26-41-59
Воронеж (473)204-51-73
Екатеринбург (343)384-55-89
Иваново (4932)77-34-06
Ижевск (3412)26-03-58
Казань (843)206-01-48

Калининград (4012)72-03-81
Калуга (4842)92-23-67
Кемерово (3842)65-04-62
Киров (8332)68-02-04
Краснодар (861)203-40-90
Красноярск (391)204-63-61
Курск (4712)77-13-04
Липецк (4742)52-20-81
Магнитогорск (3519)55-03-13
Москва (495)268-04-70
Мурманск (8152)59-64-93
Набережные Челны (8552)20-53-41

Нижний Новгород (831)429-08-12
Новокузнецк (3843)20-46-81
Новосибирск (383)227-86-73
Орел (4862)44-53-42
Оренбург (3532)37-68-04
Пенза (8412)22-31-16
Пермь (342)205-81-47
Ростов-на-Дону (863)308-18-15
Рязань (4912)46-61-64
Самара (846)206-03-16
Санкт-Петербург (812)309-46-40
Саратов (845)249-38-78

Смоленск (4812)29-41-54
Сочи (862)225-72-31
Ставрополь (8652)20-65-13
Тверь (4822)63-31-35
Томск (3822)98-41-53
Тула (4872)74-02-29
Тюмень (3452)66-21-18
Ульяновск (8422)24-23-59
Уфа (347)229-48-12
Челябинск (351)202-03-61
Череповец (8202)49-02-64
Ярославль (4852)69-52-93

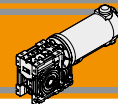

Indice	Index	Pag. Page
Caratteristiche tecniche	<i>Technical features</i>	N2
Designazione	<i>Classification</i>	N2
Simbologia	<i>Symbols</i>	N2
Lubrificazione	<i>Lubrication</i>	N3
Carichi radiali	<i>Radial loads</i>	N3
Dati di dentatura	<i>Toothing data</i>	N4
Rendimento	<i>Efficiency</i>	N4
Dati tecnici per servizio S2	<i>Technical data for S2 duty</i>	N5
Motori applicabili	<i>Motor adapters</i>	N6
Dimensioni	<i>Dimensions</i>	N7
Opzioni	<i>Options</i>	N20
Accessori	<i>Accessories</i>	N20

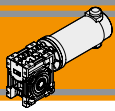

Caratteristiche tecniche

Technical features

Le caratteristiche principali dei motoriduttori CC a vite senza fine a magneti permanenti in ferrite serie ECM sono:

The main features of ECM ferrite permanent magnets DC wormgearmotors range are:

- Alimentazione in bassa tensione 12/24 Vcc
- Possibilità di montaggio encoder
- Potenze motore disponibili da 100 a 800W S2
- Magneti in ferrite
- Carcasse dei riduttori in pressofusione di alluminio
- Lubrificazione permanente con olio sintetico.

- Low voltage power supply 12/24 Vdc
- Suitable for encoder assembly
- Motor power ratings available from 100 to 800W S2
- Ferrite magnets
- Die-cast aluminum housing
- Permanent synthetic oil long-life lubrication.

Designazione

Classification

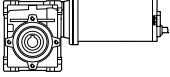
MOTORIDUTTORE / GEARMOTOR													
ECM	070/026						U	10	SZDX	BRSX	90	240	VS
Tipo Type	Grandezza Size						Versione Riduttore Gearbox Version	Rapporto Ratio	Albero di uscita Output shaft	Braccio di reazione Torque arm	Angolo Angle	Versione Motore Motor Version	Opzioni Options
 ECM	070/026	100/026	180/026	250/030	350/030	600/040	U FD FS FLD FLS FBD FBS	Vedere tabella See tables	SZDX SZSX DZ	BRDX BRSX	0° 90° 180° 270°	120 240 24E	VS
	070/030	100/030	180/030	250/040	350/040	600/050							
	100/040	180/040	250/050	350/050	600/063	600/070							

Versione Riduttore
Gearbox Version

Albero di uscita
Output shaft

Braccio di reazione
Torque arm

Angolo
Angle

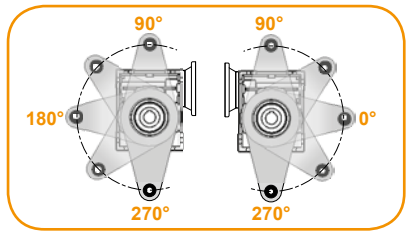
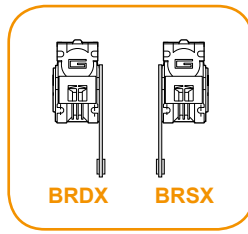
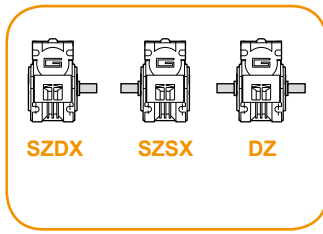
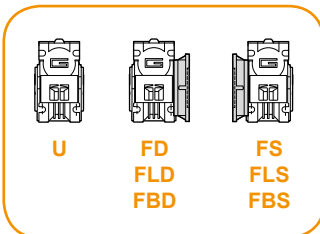

Simbologia

Symbols

n_1 [min ⁻¹]	Velocità in ingresso / Input speed	R_d %	Rendimento dinamico / Dynamic efficiency
n_2 [min ⁻¹]	Velocità in uscita / Output speed	A_2 [N]	Carico assiale ammissibile in uscita / Permitted output axial load
i	Rapporto di riduzione / Ratio	R_s %	Rendimento statico / Static efficiency
P_1 [kW]	Potenza in entrata / Input power	R_2 [N]	Carico radiale ammissibile in uscita / Permitted output radial load
M_2 [Nm]	Coppia in uscita in funzione di P_1 / Output torque referred to P_1	Z	Numero di principi della vite / Worm starts
sf	Fattore di servizio / Service factor	β	Angolo d'elica / Helix angle

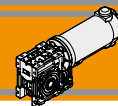

Lubrificazione

Lubrication

I riduttori a vite senza fine della serie CM sono lubrificati a vita con olio sintetico di viscosità 320 e possono essere installati in qualunque posizione di montaggio.

Permanent synthetic oil long-life lubrication allow to use CM wormgearbox range in all mounting position.

Carichi radiali

Radial loads

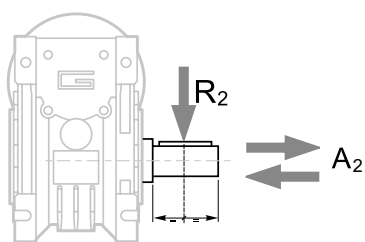

$A_2 = R_2 \times 0.2$

n ₂ [min ⁻¹]	R ₂ [N]					
	CM026	CM030	CM040	CM050	CM063	CM070
187	400	674	1264	1770	2445	2613
140	490	743	1392	1949	2692	2878
93	580	851	1596	2234	3085	3298
70	610	936	1754	2456	3392	3626
56	610	1008	1890	2646	3654	3906
47	610	1069	2004	2805	3874	4141
35	610	1179	2210	3095	4273	4568
28	610	1270	2381	3334	4603	4921
23	610	1356	2542	3559	4915	5254
18	610	1471	2759	3862	5334	5702
14	610	1600	3000	4200	5800	6200

Quando il carico radiale risultante non è applicato sulla mezzeria dell'albero occorre calcolare quello effettivo con la seguente formula:

When the resulting radial load is not applied on the centre line of the shaft it is necessary to calculate the effective load with the following formula:

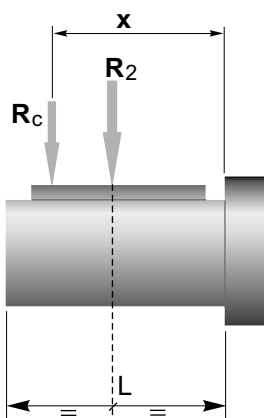

$$R_c = \frac{R_2 \cdot a}{(b+x)} \leq R_{2MAX}$$

$$R \leq R_c$$

a, b = valori riportati nella tabella
a, b = values given in the table

	CM					
	026	030	040	050	063	070
a	56	65	84	101	120	122
b	43	50	64	76	95	92
R _{2MAX}	610	1600	3000	4200	5800	6200

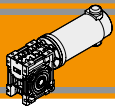

Dati di dentatura

Toothing data

	Dati della coppia vite-corona Worm wheel data	Rapporto / Ratio											
		5	7.5	10	15	20	25	30	40	50	60	80	100
CM026	Z	6	4	3	2	2		1	1	1	1		
	β	34° 35'	24° 41'	19° 1'	12° 57'	10° 30'		6° 33'	5° 17'	4° 26'	3° 49'		
CM030	Z	6	4	3	2	2	2	1	1	1	1	1	1
	β	27° 4'	24° 28'	18° 50'	12° 49'	10° 23'	8° 43'	6° 29'	5° 14'	4° 23'	3° 46'	2° 57'	2° 25'
CM040	Z	6	4	3	2	2	2	1	1	1	1	1	1
	β	34° 19'	24° 28'	18° 50'	12° 49'	10° 23'	8° 43'	6° 29'	5° 14'	4° 23'	3° 46'	2° 57'	2° 25'
CM050	Z	6	4	3	2	2	2	1	1	1	1	1	1
	β	33° 37'	23° 54'	18° 23'	12° 29'	10° 6'	8° 28'	6° 19'	5° 5'	4° 15'	3° 39'	2° 51'	2° 20'
CM063	Z	6	4	3	2	2	2	1	1	1	1	1	1
	β	34° 23'	24° 31'	18° 53'	12° 50'	10° 24'	8° 44'	6° 30'	5° 14'	4° 23'	3° 47'	2° 57'	2° 25'
CM070	Z		4	3	2	2	2	1	1	1	1	1	1
	β		26° 12'	20° 15'	13° 49'	11° 15'	9° 29'	7° 0'	5° 41'	4° 46'	4° 7'	3° 13'	2° 39'

Rendimento

Efficiency

	n ₁ [min ⁻¹]	Rendimento Efficiency	Rapporto / Ratio											
			5	7.5	10	15	20	25	30	40	50	60	80	100
CM026	2800	Rd	89	87	85	83	80		73	68	64	60		
	1400		87	84	83	78	74		66	61	57	53		
	900		84	83	80	75	71		61	57	52	48		
			Rs	72	71	68	61	56		46	41	36	34	
CM030	2800	Rd	89	88	86	84	81	78	74	70	65	62	57	52
	1400		86	85	84	79	75	72	67	62	58	55	48	43
	900		84	83	81	75	71	68	62	58	53	49	43	39
			Rs	72	67	63	55	50	43	39	35	31	27	23
CM040	2800	Rd	90	89	87	84	83	80	77	73	69	66	60	56
	1400		88	86	84	81	78	74	70	65	60	58	52	46
	900		86	84	82	77	74	70	66	60	57	53	46	41
			Rs	74	71	67	60	55	51	45	40	36	32	28
CM050	2800	Rd	91	90	88	86	84	82	78	74	71	68	62	58
	1400		89	87	85	82	79	76	72	67	63	60	54	49
	900		87	85	84	79	75	72	68	62	59	55	48	43
			Rs	73	70	66	59	55	51	44	39	35	32	27
CM063	2800	Rd	91	90	88	86	84	83	79	76	73	70	65	60
	1400		90	88	86	84	81	78	75	70	66	63	57	52
	900		89	86	84	81	78	75	70	65	61	58	52	47
			Rs	73	71	67	60	55	51	45	40	36	33	28
CM070	2800	Rd		90	89	87	85	84	80	77	74	72	67	62
	1400			89	87	84	82	80	76	72	68	65	60	53
	900			87	85	82	79	77	72	67	63	60	54	49
			Rs		72	69	62	60	55	48	43	38	36	31



Rendimento teorico del riduttore dopo il rodaggio
Theoretical efficiency of the gearbox after the first running period

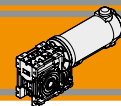

Dati tecnici per servizio S2

Technical data for S2 duty

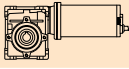
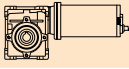
P ₁ [W]	n ₂ [min ⁻¹]	M ₂ [Nm]	sf	i		Versione motore Motor version
100						
(3000 min ⁻¹)	600	1.4	7.1	5		ECM070/026 12E/24E
	400	2.1	5.3	7.5		
	300	2.7	4.1	10		
	200	4.0	2.8	15		
	150	5.1	2.2	20		
	100	7.0	1.7	30		
	75	8.7	1.3	40		
	60	10	1.0	50		
	50	11	0.8	60		
	600	1.4	9.2	5		
	400	2.1	7.1	7.5		
	300	2.7	5.8	10		
	200	4.0	4.0	15		
	150	5.2	2.7	20		
	120	6.2	2.4	25		
	100	7.1	2.5	30		
	75	8.9	1.8	40		
	60	10	1.4	50		
	50	12	1.2	60		
	38	15	0.8	80		
	30	17	0.7	100		

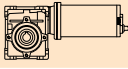
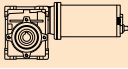
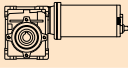
P ₁ [W]	n ₂ [min ⁻¹]	M ₂ [Nm]	sf	i		Versione motore Motor version
140						
(3000 min ⁻¹)	600	2.0	5.0	5		ECM100/026 120/240/24E
	400	2.9	3.8	7.5		
	300	3.8	2.9	10		
	200	5.5	2.0	15		
	150	7.1	1.5	20		
	100	10	1.2	30		
	75	12	0.9	40		
	60	14	0.7	50		
	50	13	0.7	60		
	200	5.6	2.8	15		
	150	7.2	1.9	20		
	120	8.7	1.7	25		
	100	10	1.8	30		
	75	12	1.3	40		
	60	14	1.0	50		
	50	17	0.8	60		
	38	17	0.7	80		
	30	16	0.7	100		
	100	10	3.7	30		ECM100/040 120/240/24E
	75	13	2.6	40		
	60	15	2.1	50		
	50	18	1.6	60		
	38	21	1.3	80		
	30	25	1.0	100		

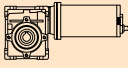
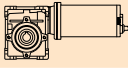
P ₁ [W]	n ₂ [min ⁻¹]	M ₂ [Nm]	sf	i		Versione motore Motor version
250						
(3000 min ⁻¹)	600	3.5	2.8	5		ECM180/026 120/240
	400	5.2	2.1	7.5		
	300	6.8	1.6	10		
	200	10	1.1	15		
	150	13	0.9	20		
	100	17	0.7	30		
	75	16	0.7	40		
	60	14	0.7	50		
	50	13	0.7	60		
	600	3.5	3.7	5		
	400	5.3	2.9	7.5		
	300	6.8	2.3	10		
	200	10	1.6	15		
	150	13	1.1	20		
	120	16	1.0	25		
	100	18	1.0	30		
	75	22	0.7	40		
	60	21	0.7	50		
	50	20	0.7	60		
	38	17	0.7	80		
	30	16	0.7	100		

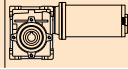
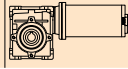
P ₁ [W]	n ₂ [min ⁻¹]	M ₂ [Nm]	sf	i		Versione motore Motor version
250						
(3000 min ⁻¹)	200	10	3.5	15		ECM180/040 120/240/24E
	150	13	2.3	20		
	120	16	1.8	25		
	100	18	2.1	30		
	75	23	1.5	40		
	60	27	1.2	50		
	50	32	0.9	60		
	38	38	0.7	80		
	30	34	0.7	100		
	75	24	2.5	40		
	60	28	2.0	50		
	50	32	1.6	60		
	38	39	1.2	80		
	30	46	0.9	100		

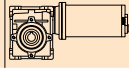
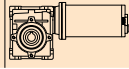
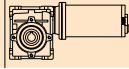
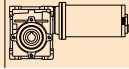
P ₁ [W]	n ₂ [min ⁻¹]	M ₂ [Nm]	sf	i		Versione motore Motor version
350						
(3000 min ⁻¹)	600	5.0	2.6	5		ECM250/030 120/240
	400	7.4	2.0	7.5		
	300	10	1.7	10		
	200	14	1.1	15		
	150	18	0.8	20		
	120	22	0.7	25		
	100	25	0.7	30		
	75	22	0.7	40		
	60	21	0.7	50		
	200	14	2.5	15		
	150	18	1.7	20		
	120	22	1.3	25		
	100	26	1.5	30		
	75	33	1.0	40		
	60	38	0.8	50		
	50	44	0.7	60		
	38	38	0.7	80		
	30	35	0.7	100		
	150	19	2.9	20		ECM250/050 120/240
	120	23	2.2	25		
	100	26	2.6	30		
	75	33	1.8	40		
	60	40	1.4	50		
	50	45	1.1	60		
	38	55	0.8	80		
	30	65	0.7	100		
	75	34	3.3	40		ECM250/063 120/240
	60	41	2.5	50		
	50	47	2.1	60		
	38	58	1.5	80		
	30	67	1.2	100		

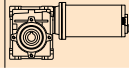
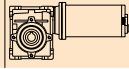
P ₁ [W]	n ₂ [min ⁻¹]	M ₂ [Nm]	sf	i		Versione motore Motor version
500						
(3000 min ⁻¹)	600	7.1	1.8	5		ECM350/030 120/240
	400	11	1.4	7.5		
	300	14	1.2	10		
	200	20	0.8	15		
	150	20	0.7	20		
	120	21	0.7	25		
	100	26	0.7	30		
	75	23	0.7	40		
	60	21	0.7	50		

N.B.
Verificare sempre che la coppia M₂ utilizzata non ecceda il valore indicato nelle caselle in grigio
N.B.
Please check that the output torque M₂ does not exceed the value in the grey areas



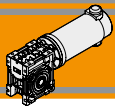

Dati tecnici per servizio S2

Technical data for S2 duty

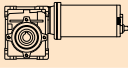
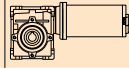
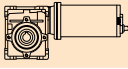
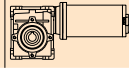
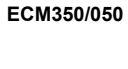
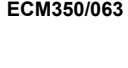
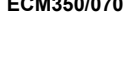
P_1 [W]	n_2 [min ⁻¹]	M_2 [Nm]	sf	i		Versione motore Motor version	P_1 [W]	n_2 [min ⁻¹]	M_2 [Nm]	sf	i		Versione motore Motor version							
500							800													
(3000 min ⁻¹)	600	7.2	4.0	5		ECM350/040	120/240	(3000 min ⁻¹)	600	11	2.5	5		ECM600/040	120/240					
	400	11	2.9	7.5					400	17	1.8	7.5					400	17	1.8	7.5
	300	14	2.4	10					300	22	1.5	10					300	22	1.5	10
	200	20	1.7	15					200	32	1.1	15					200	32	1.1	15
	150	26	1.2	20					150	42	0.7	20					150	42	0.7	20
	120	32	0.9	25					120	40	0.7	25					120	40	0.7	25
	100	37	1.0	30					100	54	0.7	30					100	54	0.7	30
	75	46	0.7	40					75	49	0.7	40					75	49	0.7	40
	60	46	0.7	50					600/050	12	4.7	5					600/050	12	4.7	5
	50	41	0.7	60					400	17	3.3	7.5					400	17	3.3	7.5
	38	39	0.7	80		300	22	2.7	10		300	22	2.7	10						
	30	34	0.7	100		200	33	1.9	15		200	33	1.9	15						
	200	21	3.0	15		ECM350/050	120/240		150	43	1.3	20		150	43	1.3	20			
	150	27	2.1	20					120	52	1.0	25		120	52	1.0	25			
	120	33	1.6	25					100	60	1.1	30		100	60	1.1	30			
	100	37	1.8	30					75	75	0.8	40		75	75	0.8	40			
	75	47	1.3	40					60	81	0.7	50		60	81	0.7	50			
	60	57	1.0	50					50	74	0.7	60		50	74	0.7	60			
	50	65	0.8	60					38	66	0.7	80		38	66	0.7	80			
	38	66	0.7	80					200/063	33	3.5	15		200/063	33	3.5	15			
	30	61	0.7	100					150	43	2.4	20		150	43	2.4	20			
	150	27	3.8	20					ECM350/063	120/240		120	53	1.8	25		120	53	1.8	25
	120	33	2.8	25		100	60				2.1	30		100	60	2.1	30			
	100	38	3.4	30		75	77				1.4	40		75	77	1.4	40			
	75	48	2.3	40		60	93				1.1	50		60	93	1.1	50			
	60	58	1.8	50		50	107				0.9	60		50	107	0.9	60			
	50	67	1.5	60		38	132				0.7	80		38	132	0.7	80			
	38	83	1.1	80		30	114				0.7	100		30	114	0.7	100			
	30	96	0.8	100		200/070	43				3.5	20		200/070	43	3.5	20			
	75	49	3.4	40		ECM350/070	120/240					120	53	2.6	25		120	53	2.6	25
	60	59	2.5	50								100	61	3.0	30		100	61	3.0	30
	50	69	2.1	60					75	78	2.1	40		75	78	2.1	40			
	38	85	1.5	80					60	94	1.6	50		60	94	1.6	50			
	30	99	1.2	100					50	110	1.3	60		50	110	1.3	60			
									38	137	0.9	80		38	137	0.9	80			
									30	158	0.7	100		30	158	0.7	100			

N.B.
Verificare sempre che la coppia M2 utilizzata non ecceda il valore indicato nelle caselle in grigio

N.B.
Please check that the output torque M2 does not exceed the value in the grey areas

Motori applicabili

Motor adapters

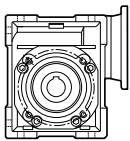
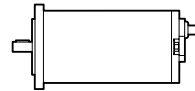

		EC						
		070.12E 070.24E	100.120 100.240 100.24E	180.120 180.240	180.24E	250.120 250.240	350.120 350.240	600.120 600.240
CM	026	5-60	5-60	5-60				
	030	5-100	5-100	5-100	5-50	5-50	5-50	
	040		5-100	5-100	5-100	5-100	5-100	5-40
	050			40-100	5-100	5-100	15-100	5-80
	063					40-100	20-100	15-100
	070						40-100	20-100

5-100

Rapporti di riduzione i
Ratio i

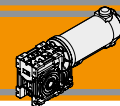

Dimensioni

Dimensions

ECM070/026 U

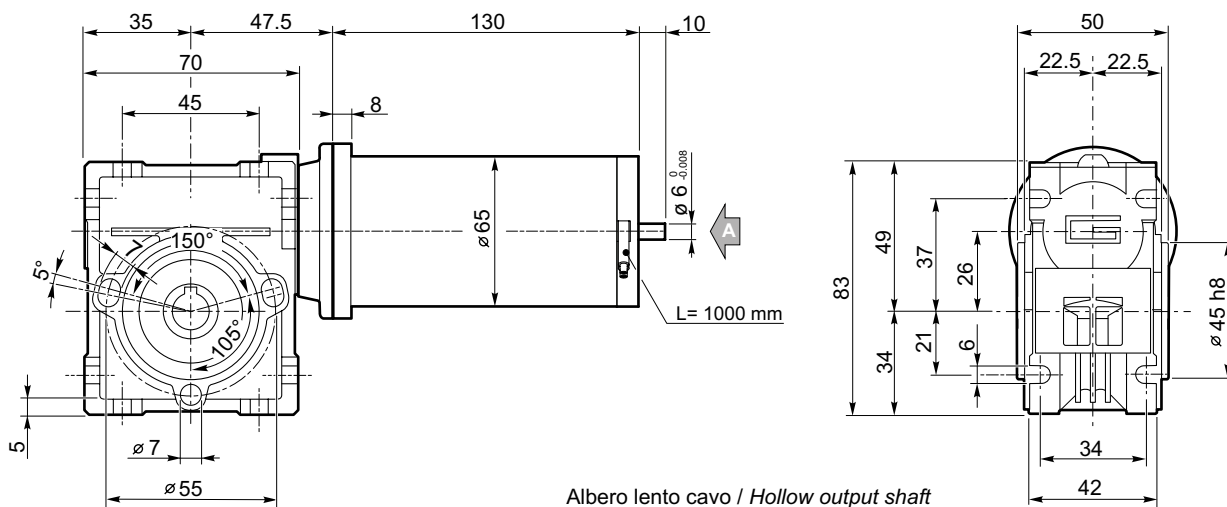

Vista da A
View from A

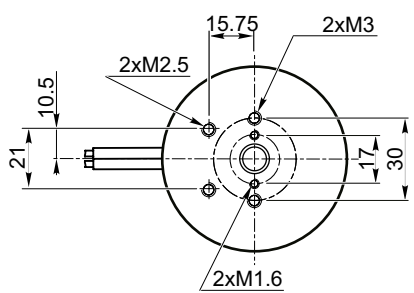

Albero lento cavo / Hollow output shaft

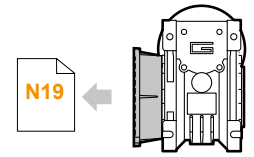
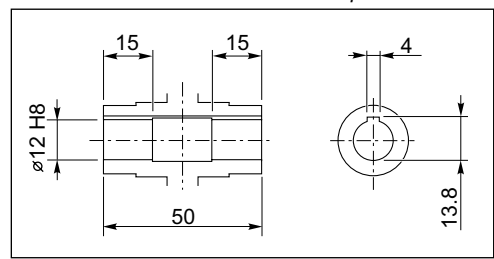

ECM070/026 F

Freno / Brake → H23

Encoder → H24

ECM070/030 U

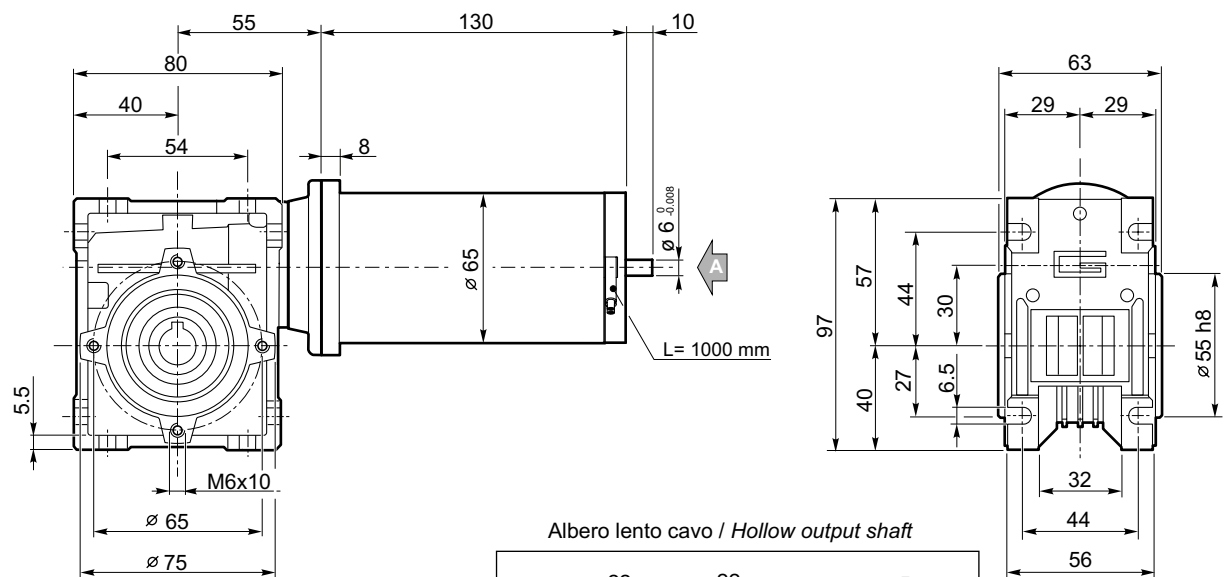

Vista da A
View from A

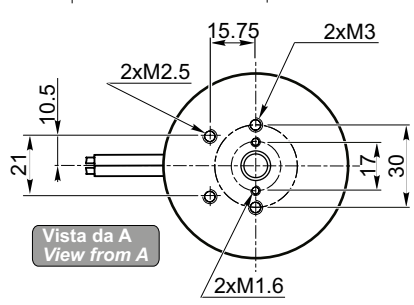

Albero lento cavo / Hollow output shaft

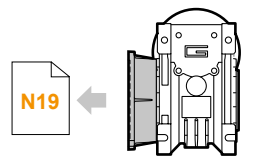
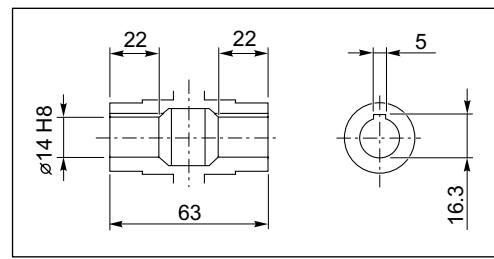

ECM070/030 F

Freno / Brake → H23

Encoder → H24

ECM

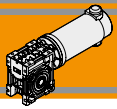

Dimensioni

Dimensions

ECM100/026 U

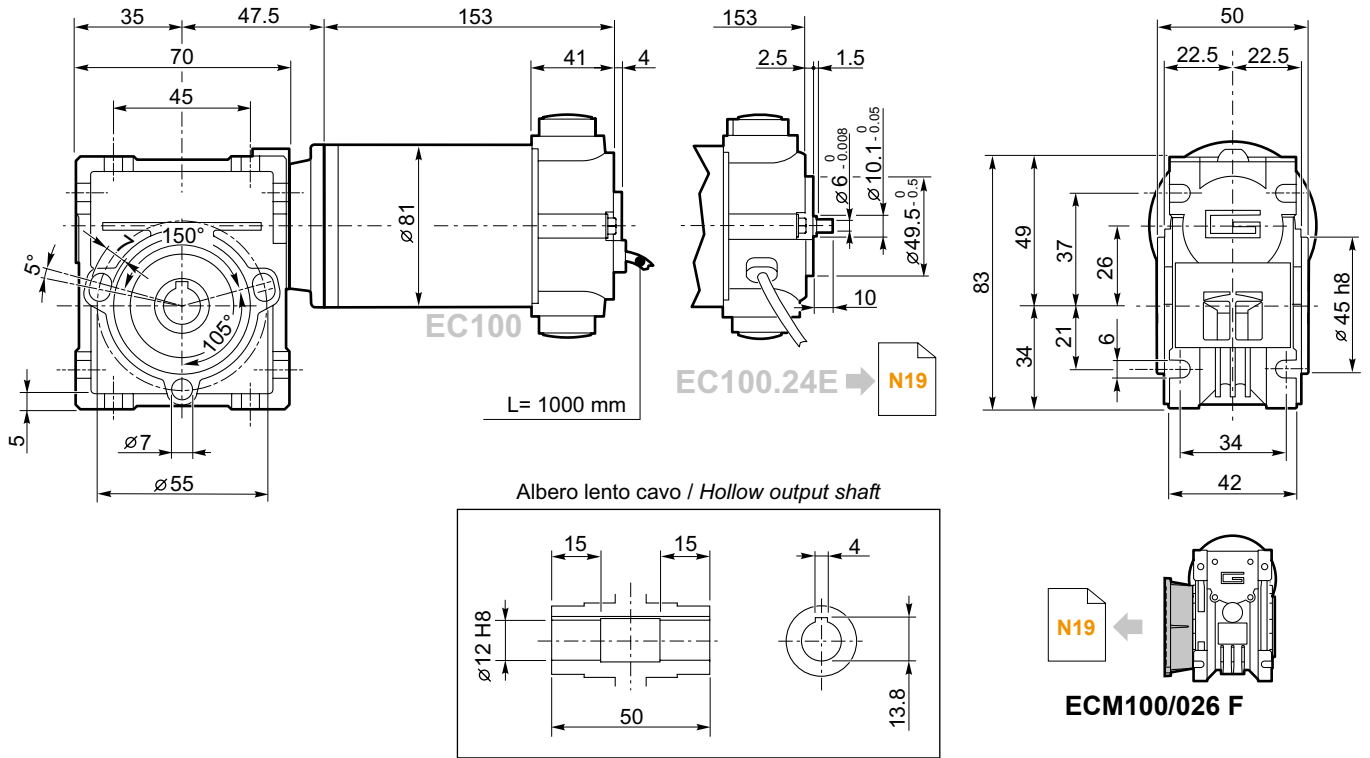

Freno / Brake → H23

Encoder → H24

ECM100/030 U

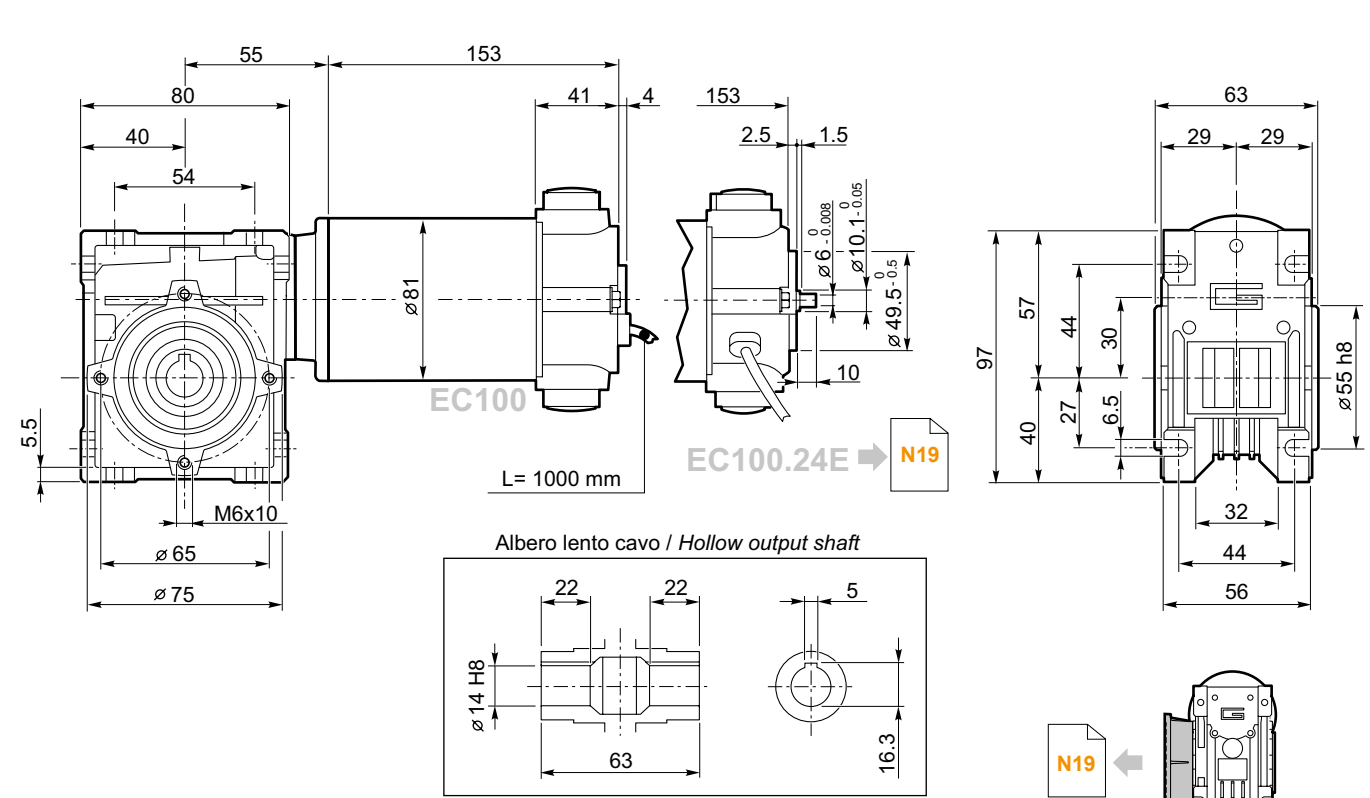

Freno / Brake → H23

Encoder → H24

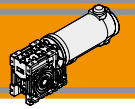

Dimensioni

Dimensions

ECM100/040 U

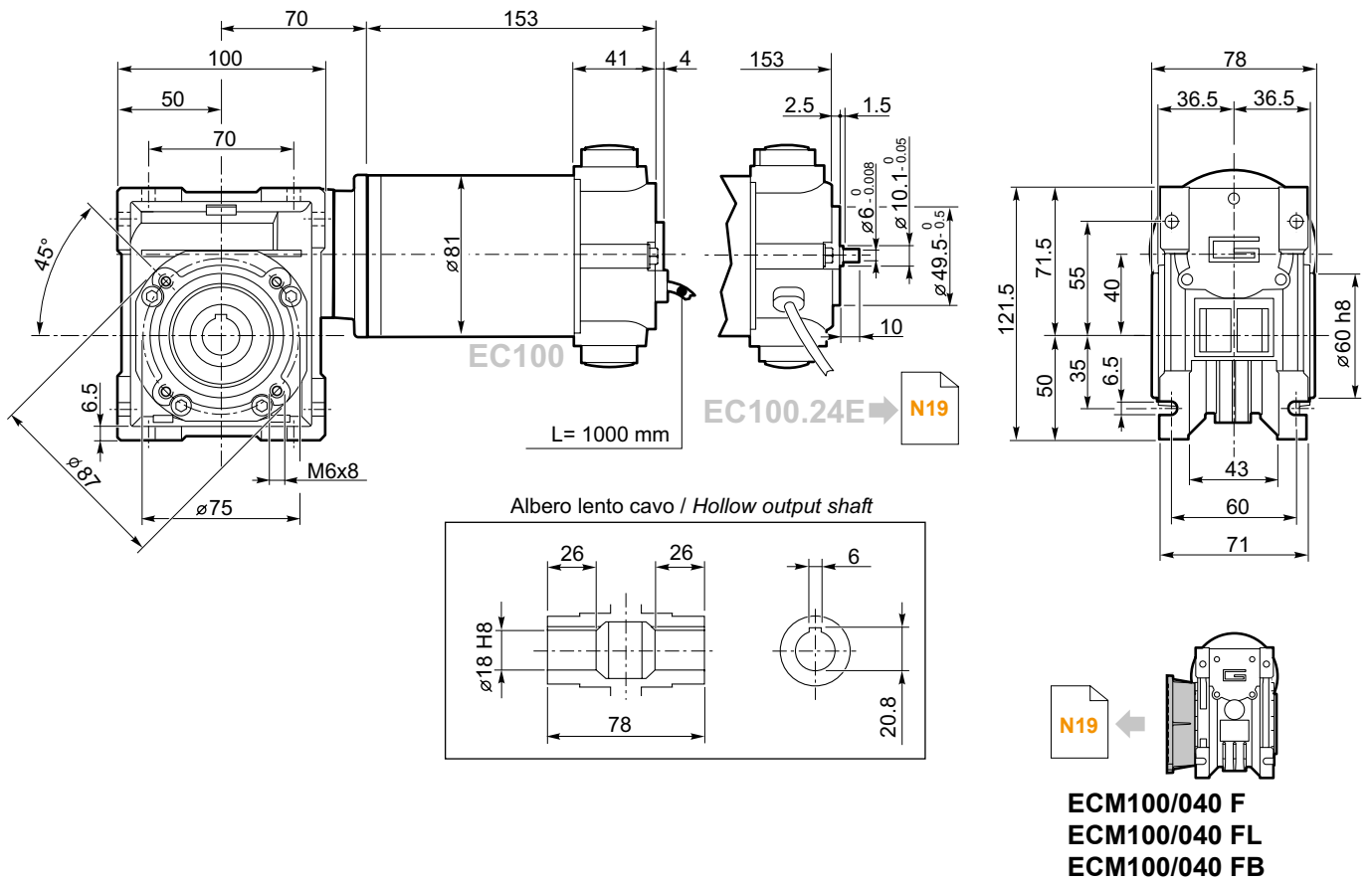

Freno / Brake →



Encoder →



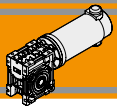

Dimensioni

Dimensions

ECM180/026 U

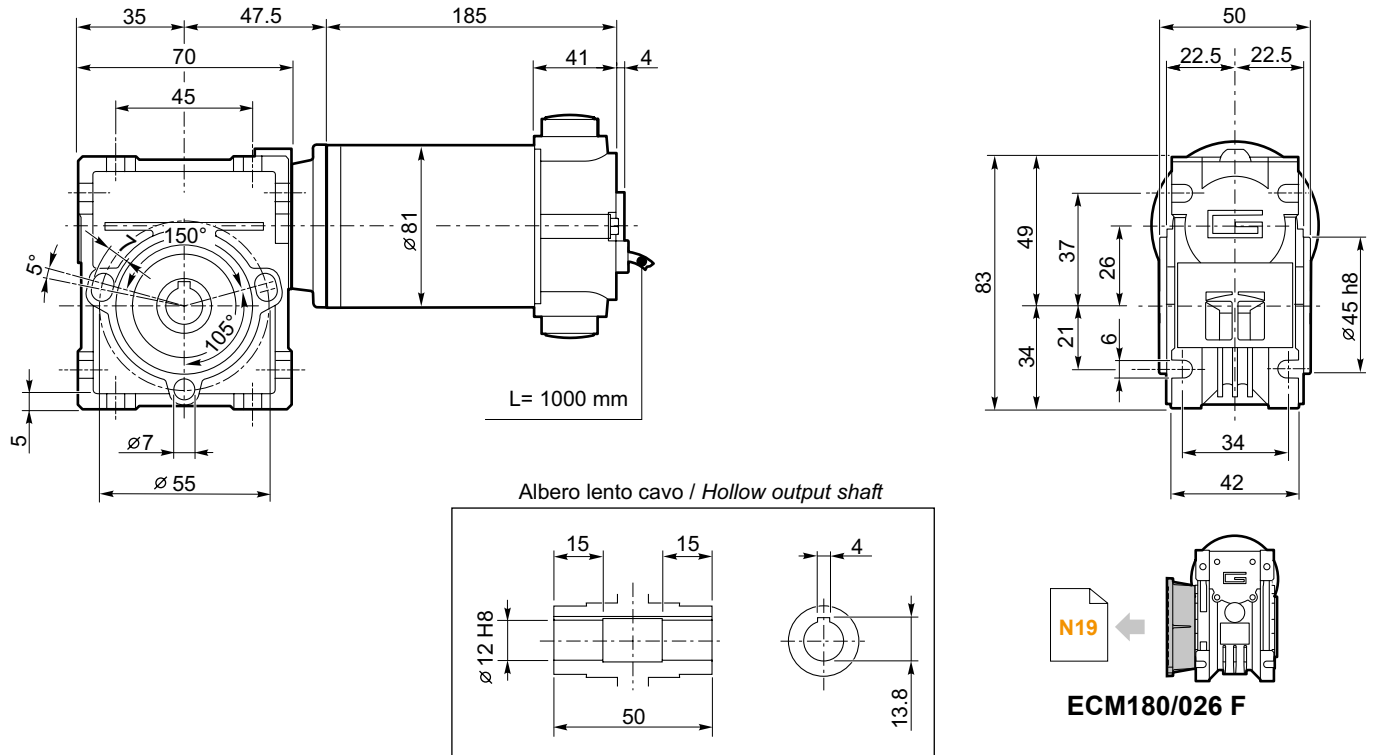

- Freno / Brake → H23
- Encoder → H24

ECM180/030 U

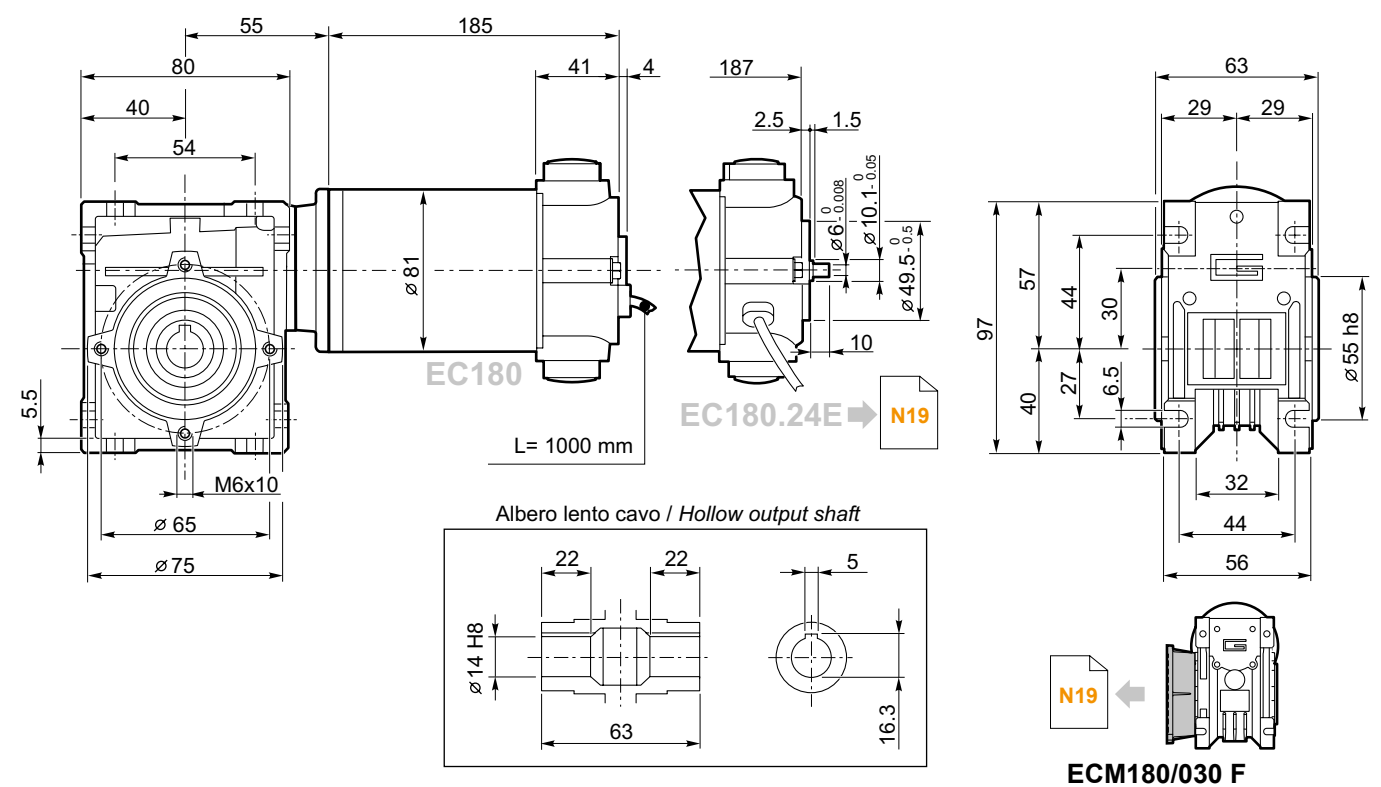

- Freno / Brake → H23
- Encoder → H24

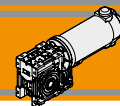

Dimensioni

Dimensions

ECM180/040 U

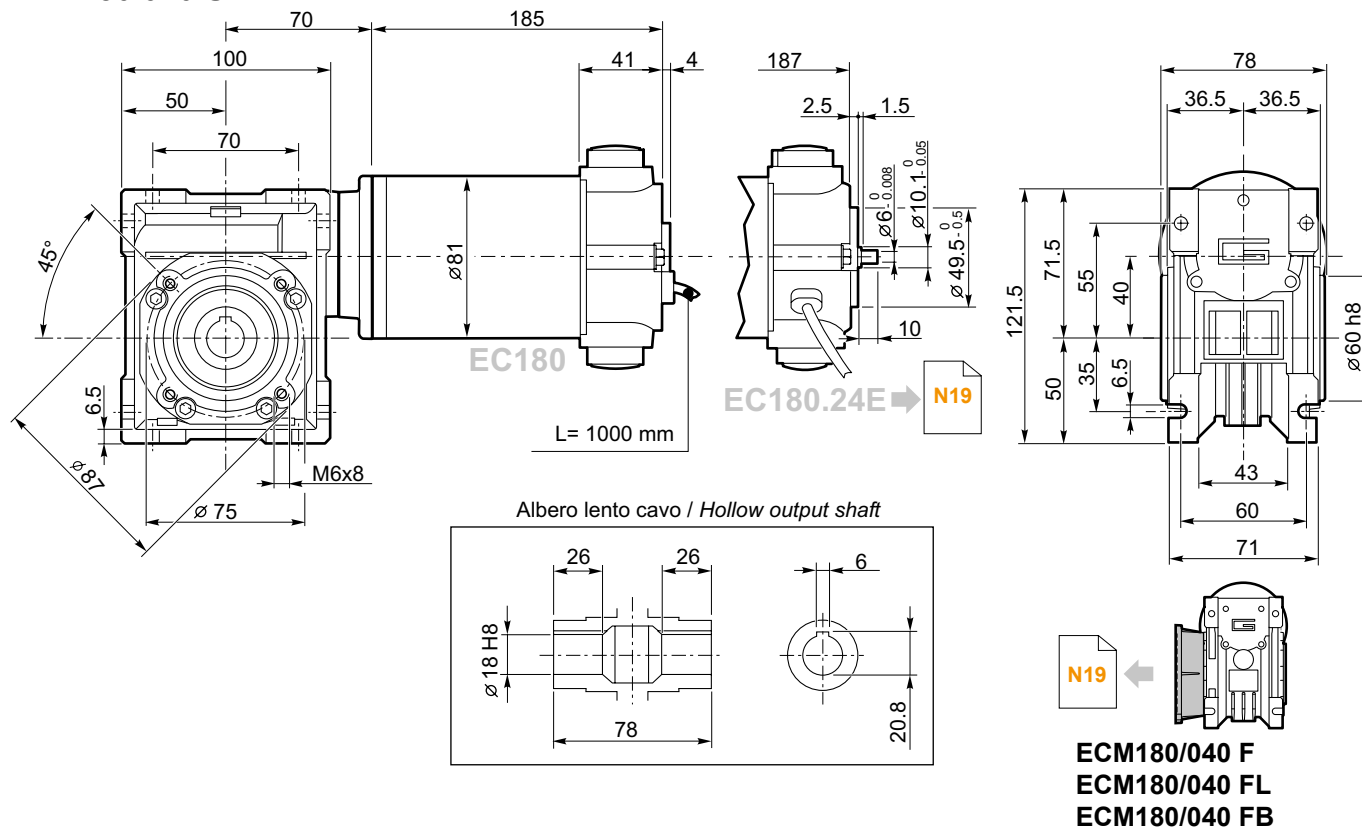

Freno / Brake → H23

Encoder → H24

ECM180/050 U

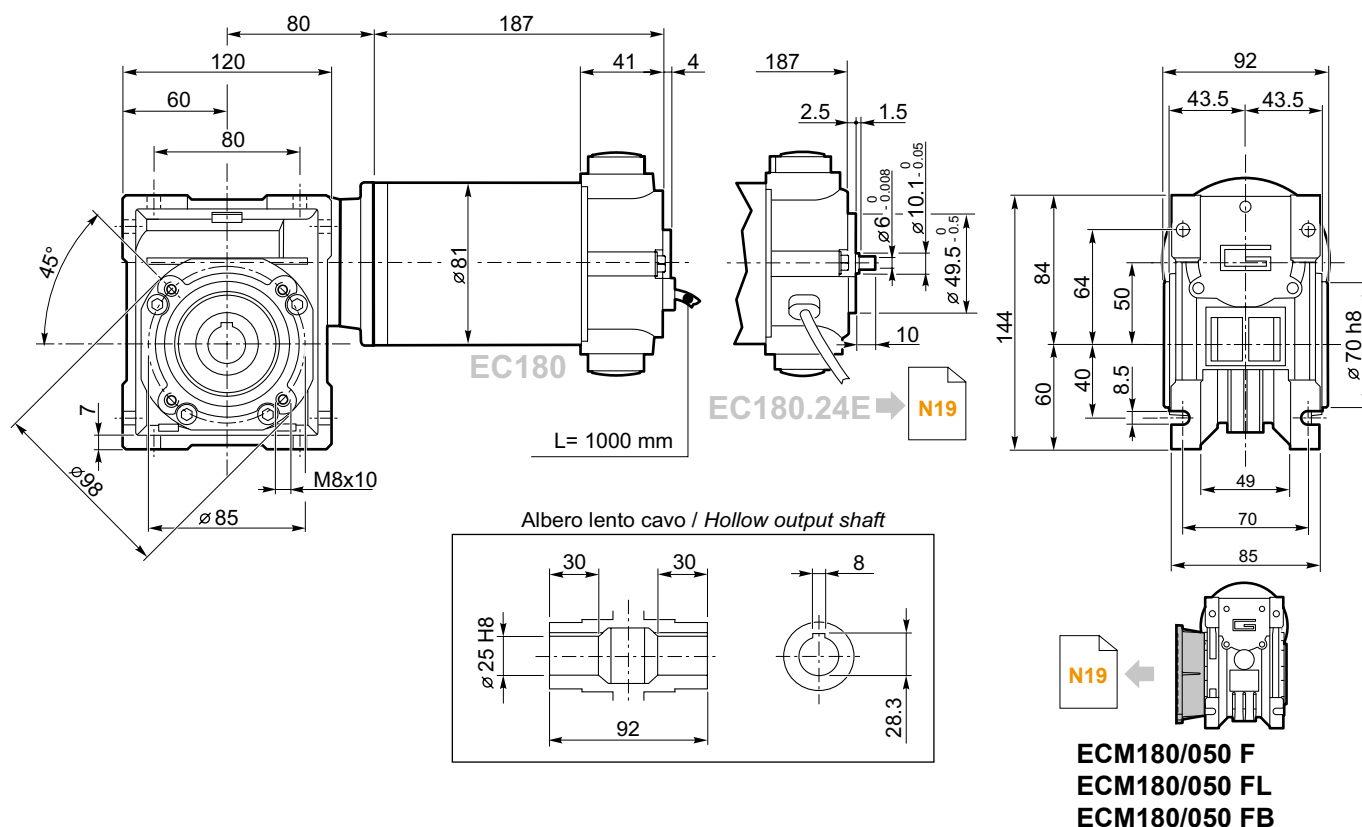

Freno / Brake → H23

Encoder → H24

ECM

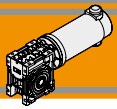

Dimensioni

Dimensions

ECM250/030 U

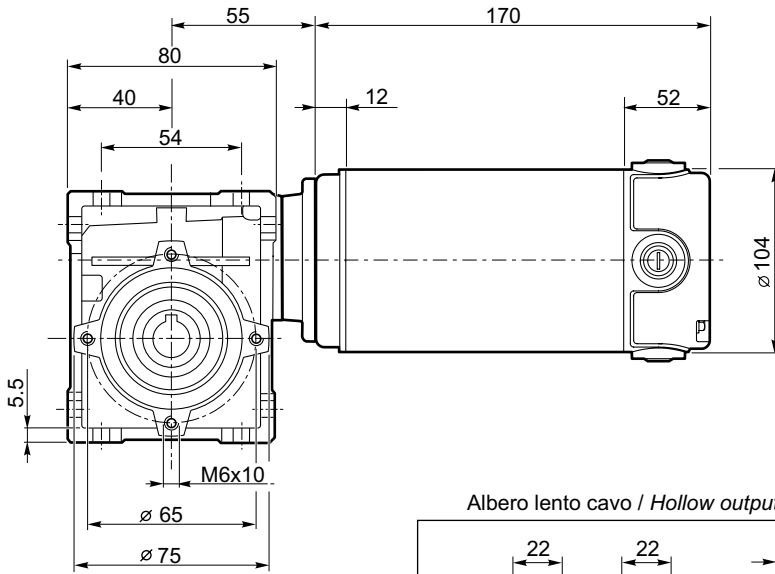

Albero lento cavo / Hollow output shaft

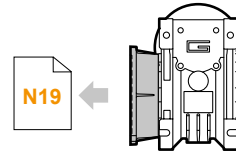
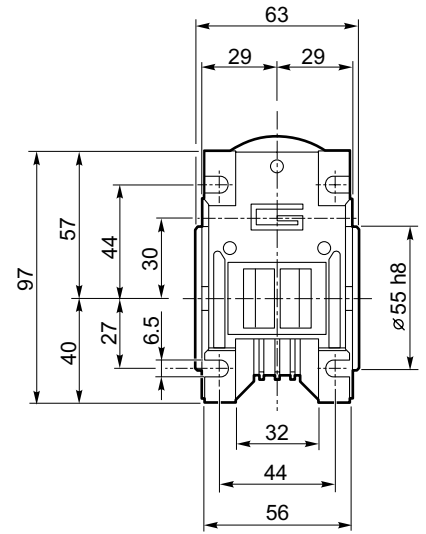
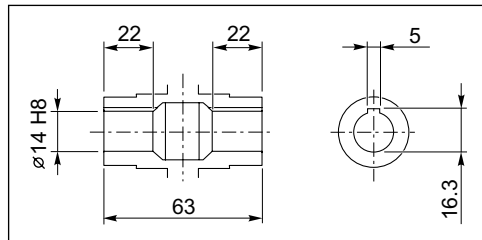

ECM250/030 F

ECM250/040 U

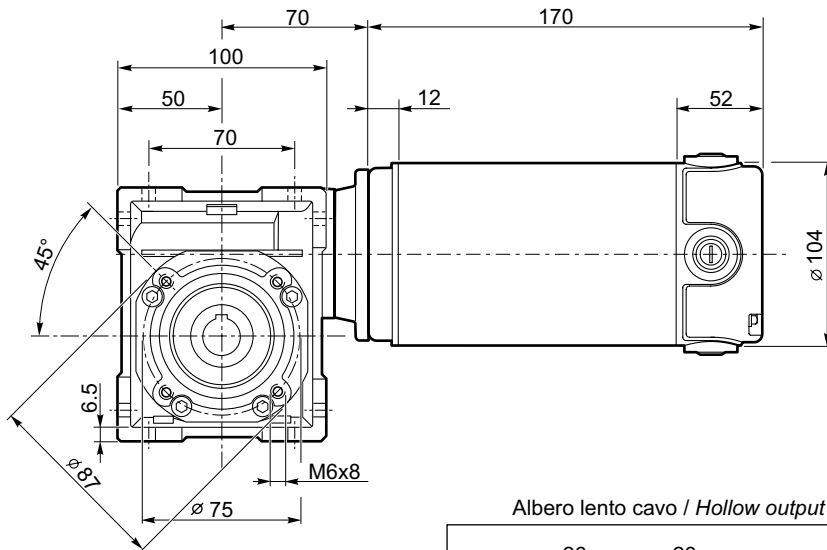

Albero lento cavo / Hollow output shaft

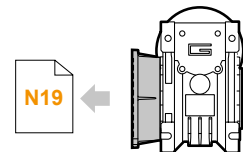
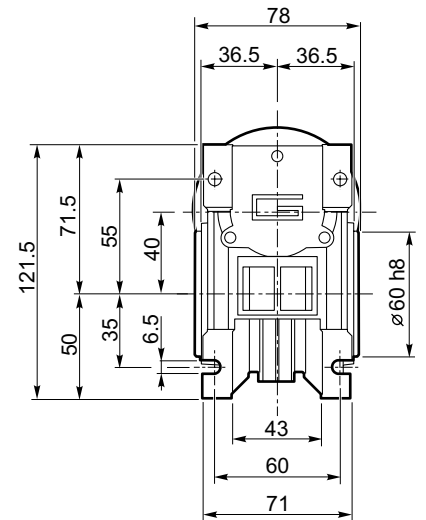
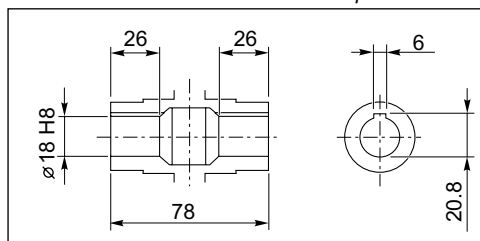

ECM250/040 F
ECM250/040 FL
ECM250/040 FB

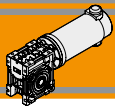

Dimensioni

Dimensions

ECM350/030 U

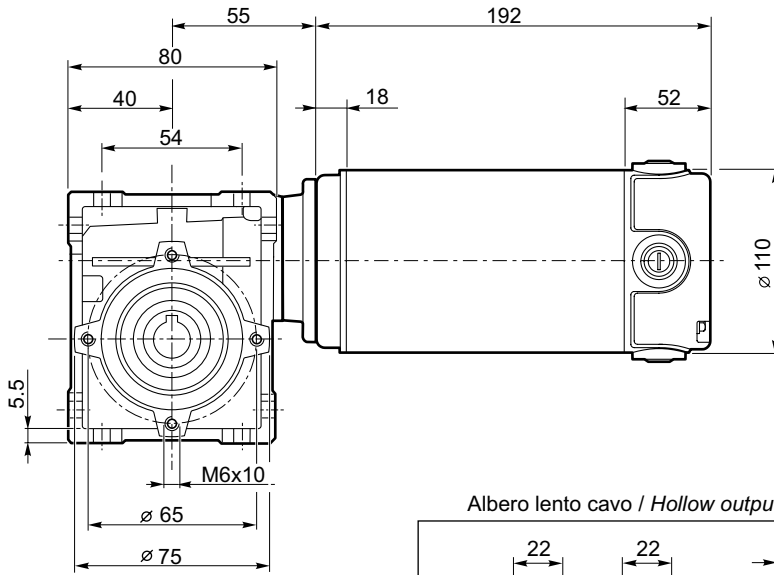

Albero lento cavo / Hollow output shaft

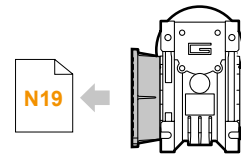
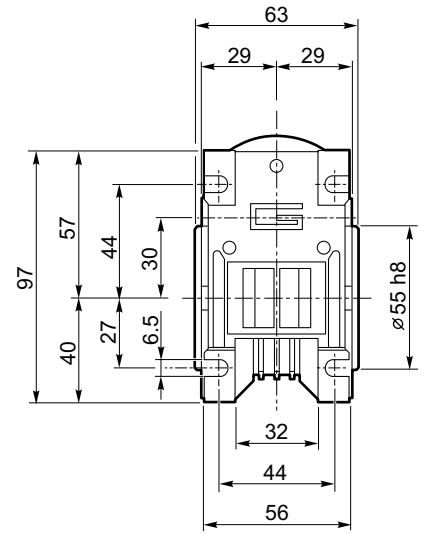
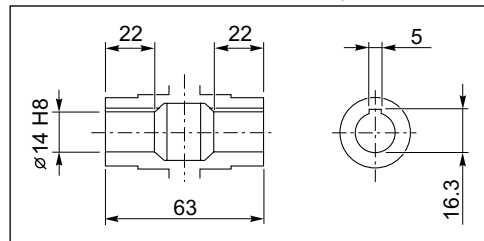

ECM350/030 F

Freno / Brake → H23

ECM350/040 U

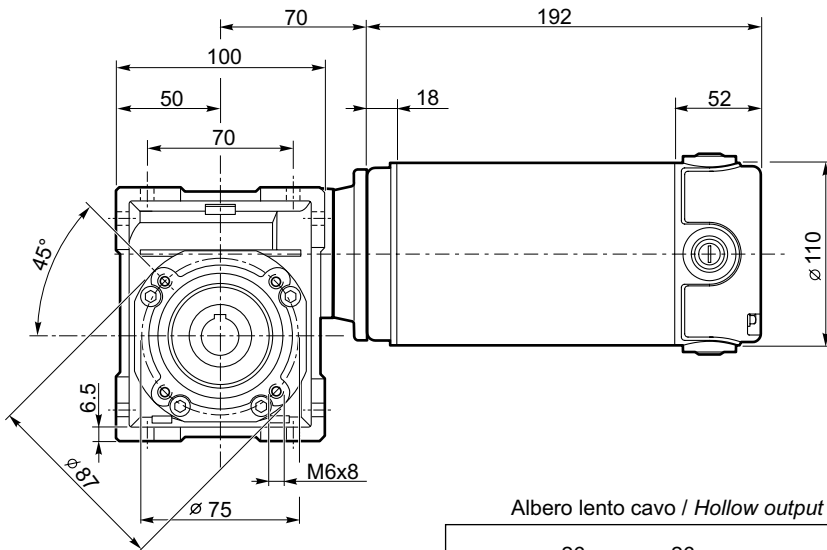

Albero lento cavo / Hollow output shaft

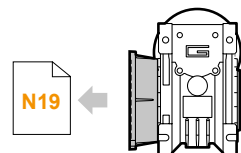
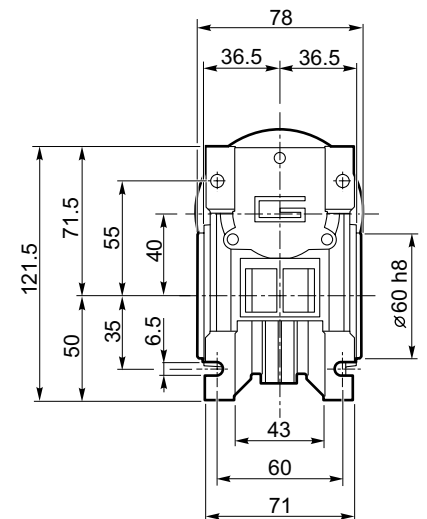
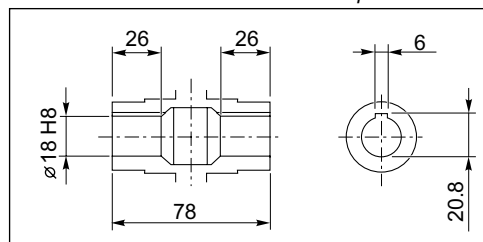

ECM350/040 F
ECM350/040 FL
ECM350/040 FB

Freno / Brake → H23

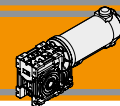

Dimensioni

Dimensions

ECM350/050 U

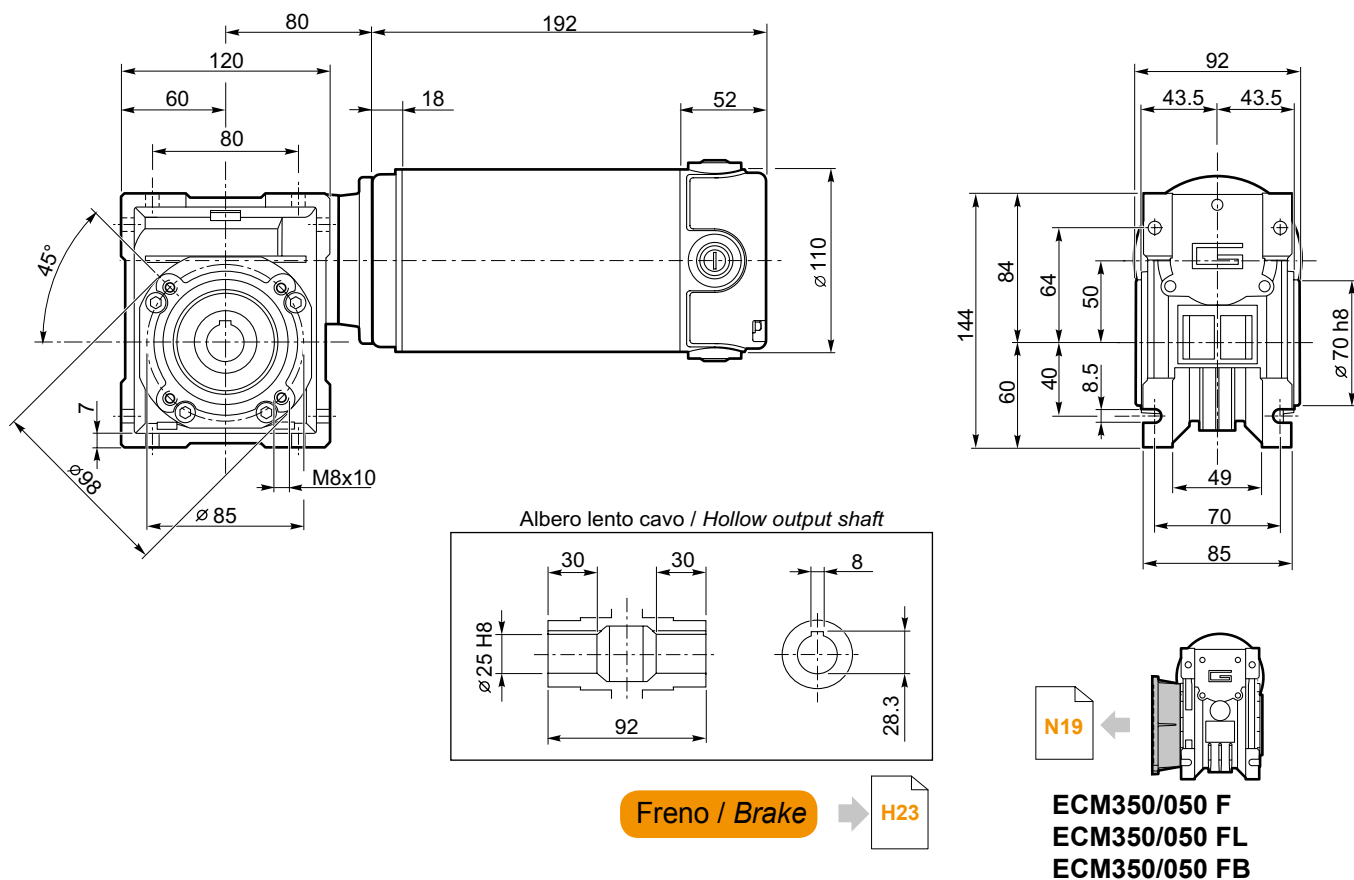

ECM350/063 U

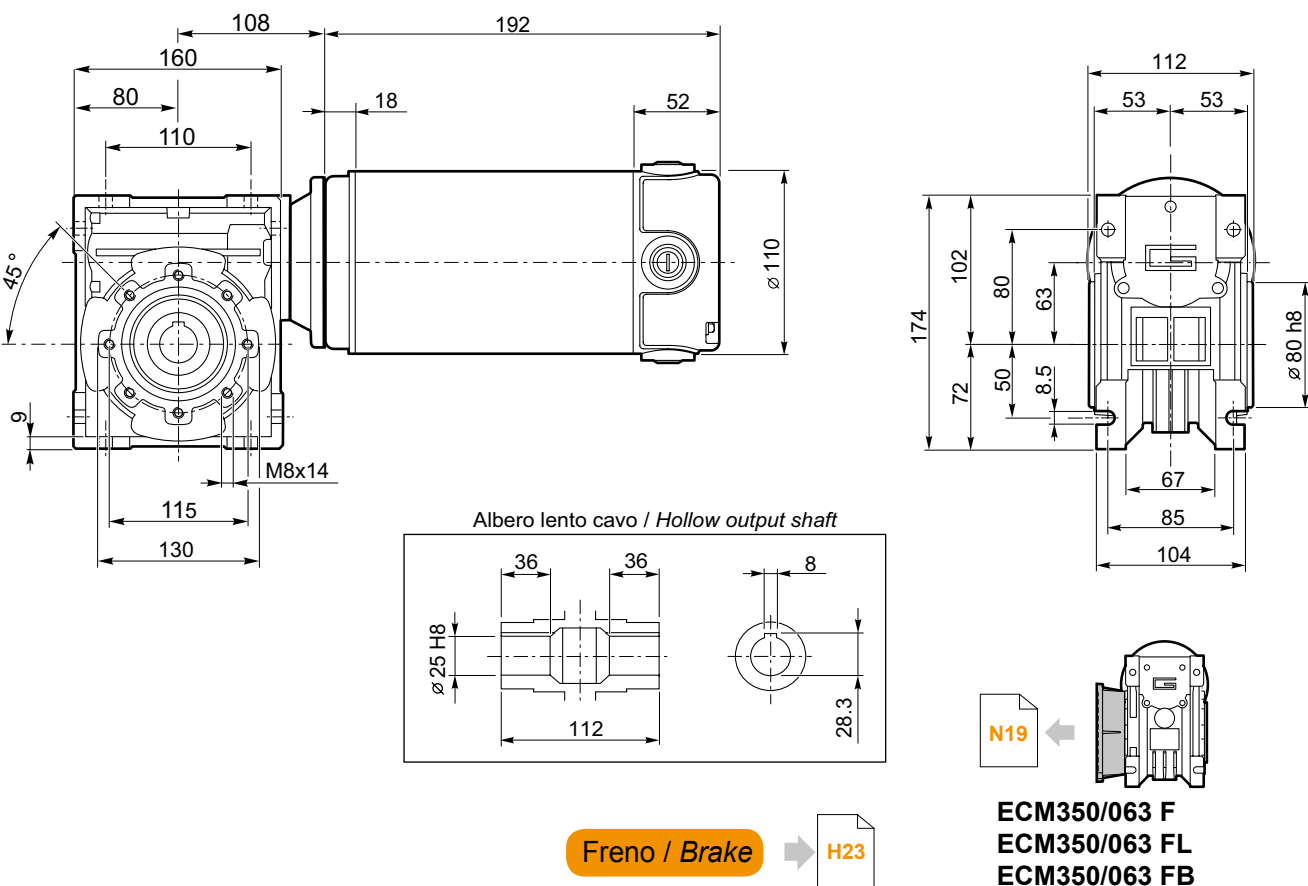

ECM

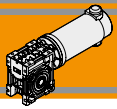

Dimensioni

Dimensions

ECM350/070 U

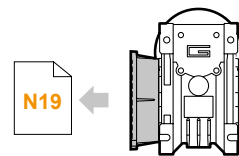
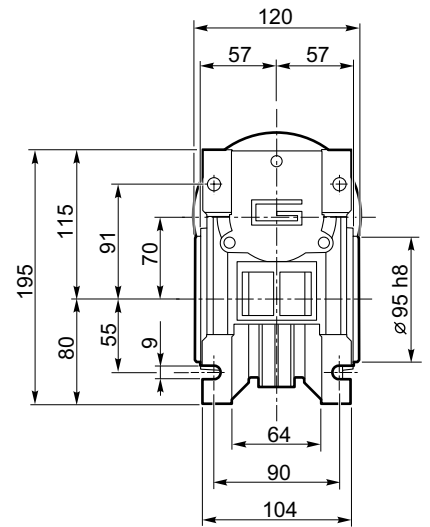
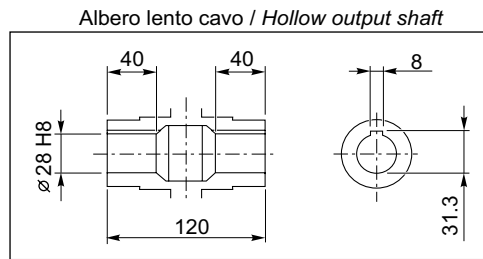
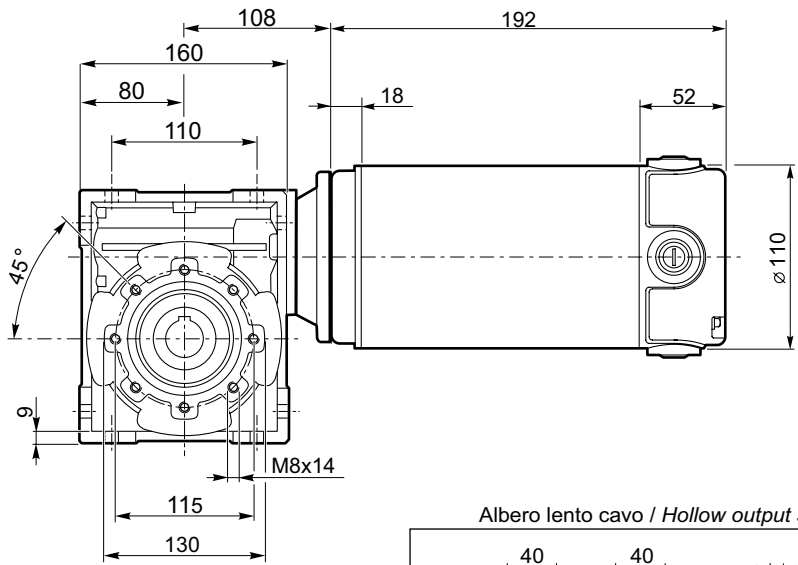

ECM350/070 F



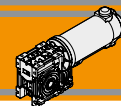

Dimensioni

Dimensions

ECM600/040 U

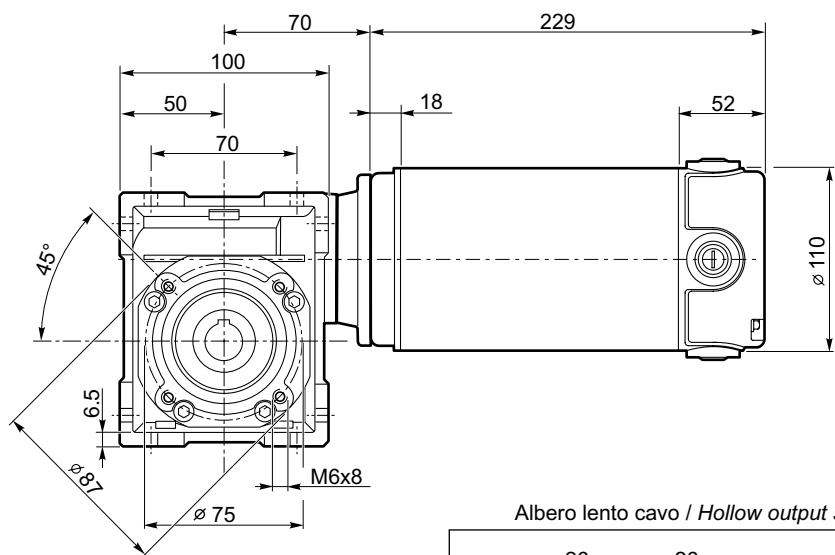

Albero lento cavo / Hollow output shaft

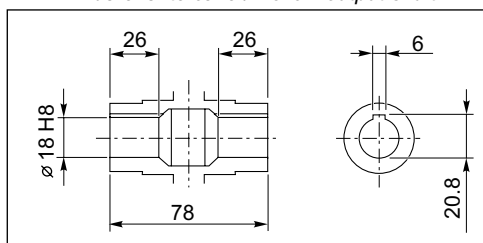

Freno / Brake

H23

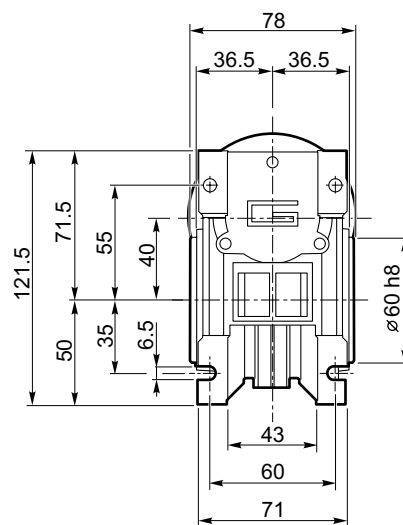

N19

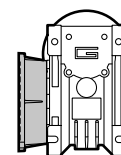

ECM600/040 F
ECM600/040 FL
ECM600/040 FB

ECM600/050 U

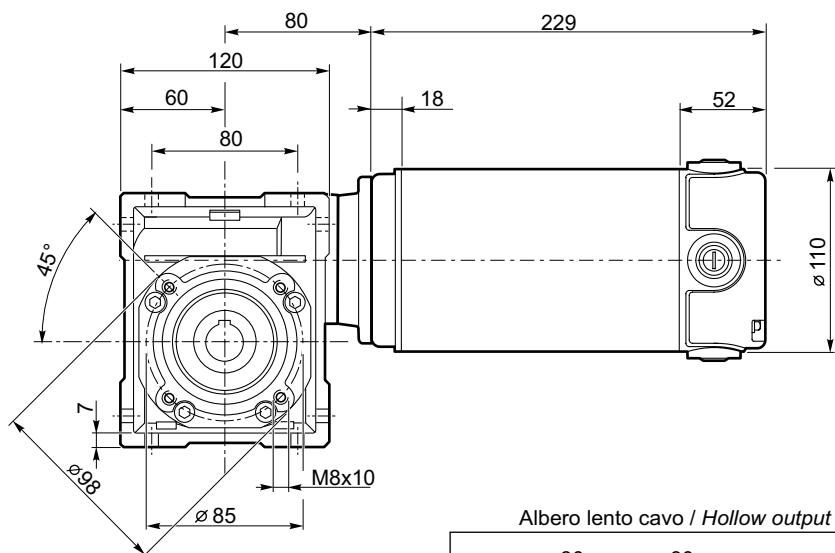

Albero lento cavo / Hollow output shaft

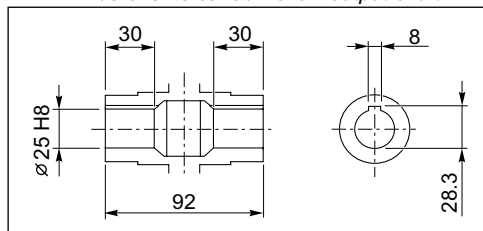

Freno / Brake

H23

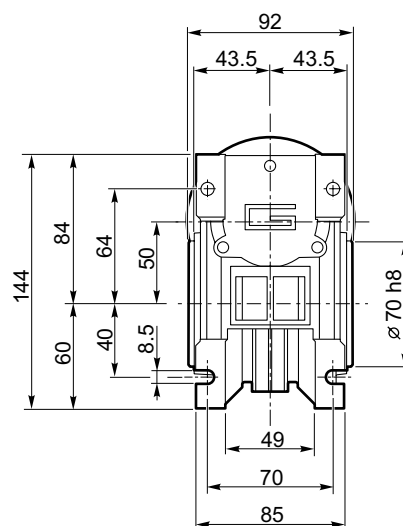

N19

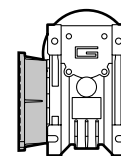

ECM600/050 F
ECM600/050 FL
ECM600/050 FB

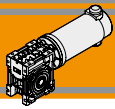

Dimensioni

Dimensions

ECM600/063 U

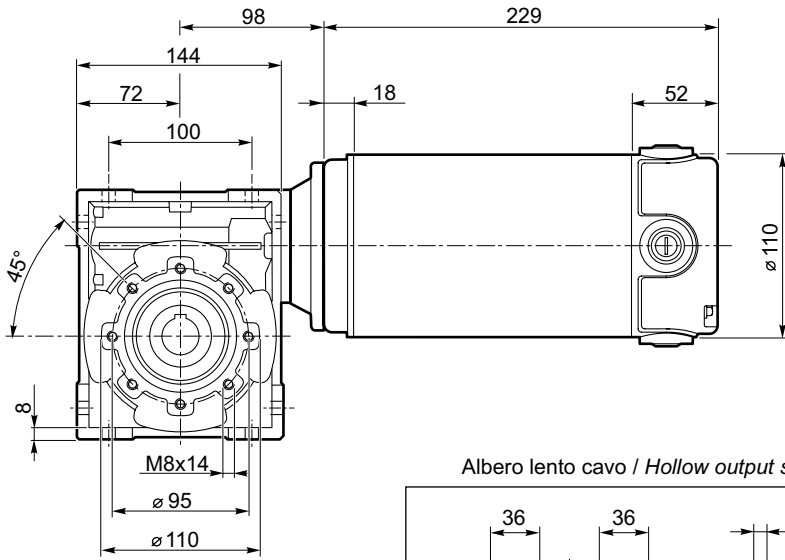

Albero lento cavo / Hollow output shaft

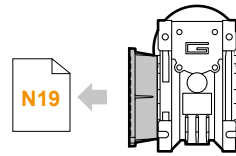
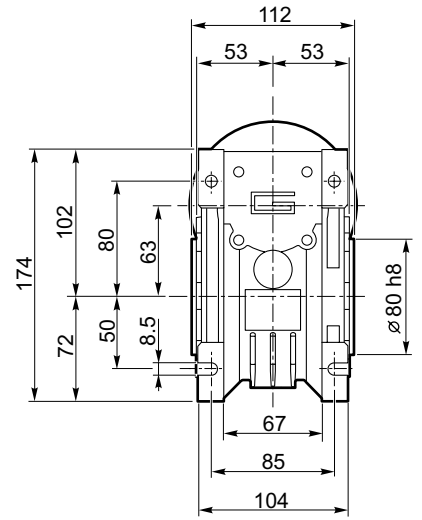
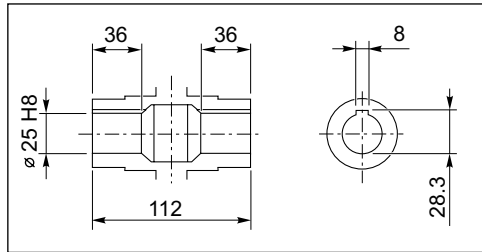

Freno / Brake → **H23**

ECM600/063 F
ECM600/063 FL
ECM600/063 FB

ECM600/070 U

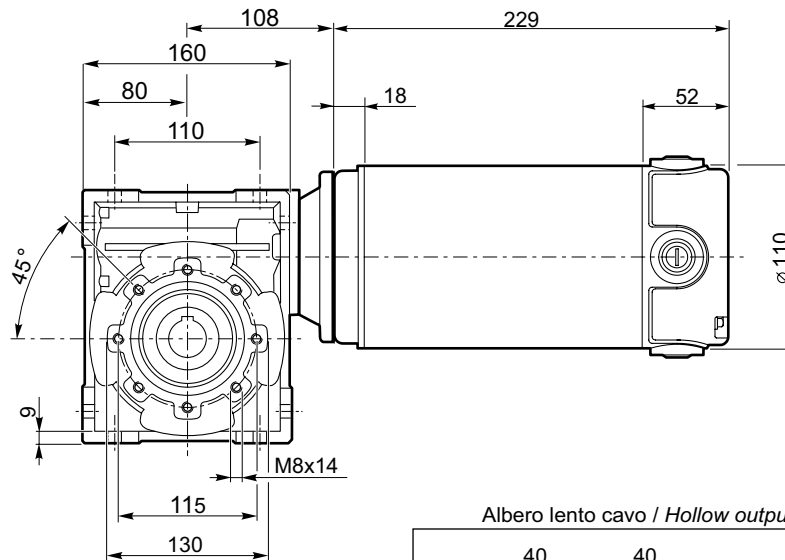

Albero lento cavo / Hollow output shaft

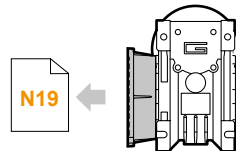
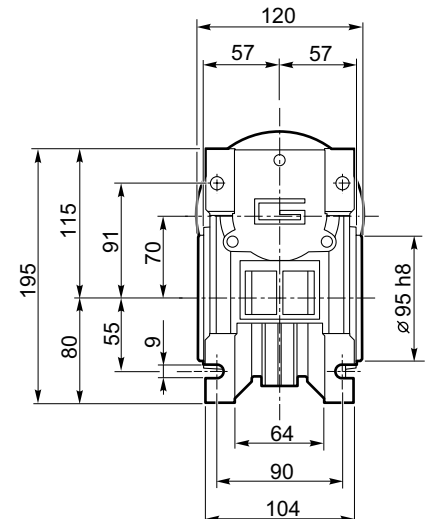
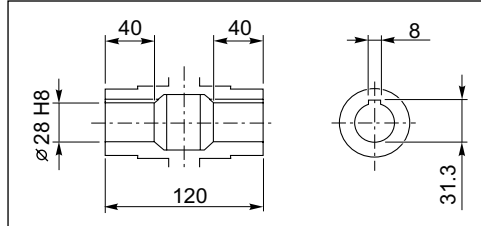

Freno / Brake → **H23**

ECM600/070 F

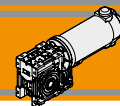

Dimensioni

Dimensions

ECM.../... F... Flange uscita / Output flanges

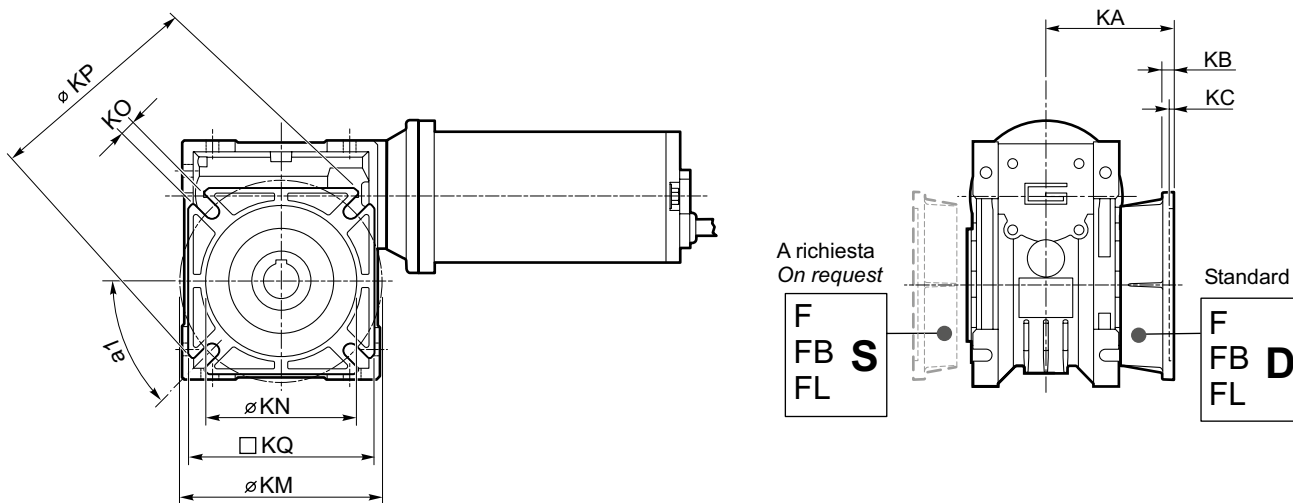

CM	CM..F									CM..FB						CM..FL									
	a1	KA	KB	KC	KM	KN _{H8}	KO	KP	KQ	KA	KB	KC	KM	KN _{H8}	KO	KP	KQ	KA	KB	KC	KM	KN _{H8}	KO	KP	KQ
026	45°	45	6	4.5	55-69	40	6.5(n.4)	75	70	—	—	—	—	—	—	—	—	—	—	—	—	—	—	—	—
030	45°	54.5	6	4	68	50	6.5(n.4)	80	70	—	—	—	—	—	—	—	—	—	—	—	—	—	—	—	—
040	45°	67	7.5	4	80-95	60	9(n.4)	110	95	80	8.5	5	115-125	95	9.5(n.4)	140	112	97	7.5	4.5	80-95	60	9(n.4)	110	95
050	45°	90	9	5	90-110	70	11(n.4)	125	110	89	9	5	130-145	110	9.5(n.4)	160	132	120	9	5	90-110	70	11(n.4)	125	110
063	45°	82	10	6	150-160	115	11(n.4)	180	142	98	10	5	165-180	130	11(n.4)	200	160	112	10	6	150-160	115	11(n.4)	180	142
070	45°	107	13	6	165-180	130	14(n.4)	200	170	—	—	—	—	—	—	—	—	—	—	—	—	—	—	—	—

EC100.24E
EC180.24E

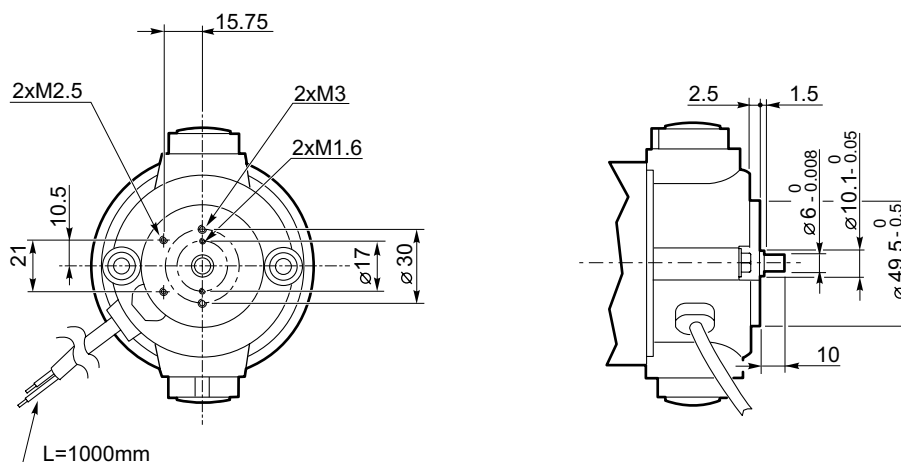

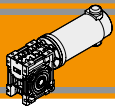

Opzioni

Options

VS - Vite sporgente / Extended input shaft

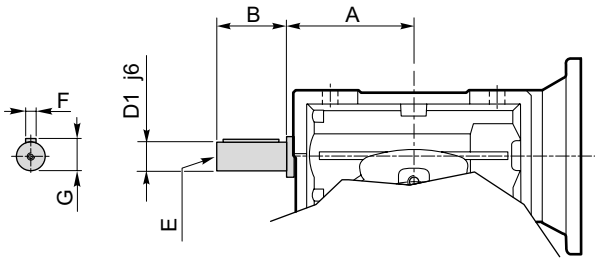

	A	B	D ₁ j6	E	F	G
CM 030	45	20	9	M4	3	10.2
CM 040	53	23	11	M5	4	12.5
CM 050	64	30	14	M6	5	16
CM 063	75	40	19	M6	6	21.5
CM 070	84	40	19	M6	6	21.5

Costruito su richiesta
Built on request

SC - Safety cover

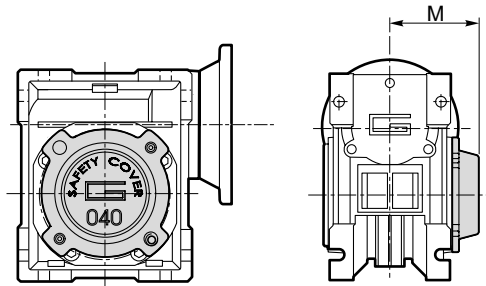

	M
CM 030	47
CM 040	54.5
CM 050	62.5
CM 063	73
CM 070	75

Accessori

Accessories

Albero lento

Output shaft

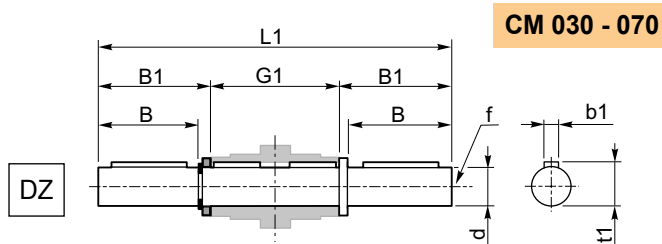

CM 030 - 070

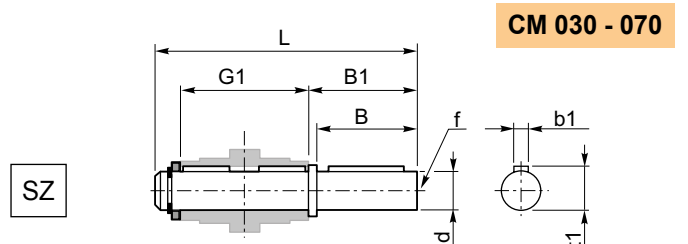

CM 030 - 070

	d h7	B	B1	G1	L	L1	f	b1	t1
CM 030	14	30	32.5	63	102	128	M6	5	16
CM 040	18	40	43	78	128	164	M6	6	20.5
CM 050	25	50	53.5	92	153	199	M10	8	28
CM 063	25	50	53.5	112	173	219	M10	8	28
CM 070	28	60	63.5	120	192	247	M10	8	31

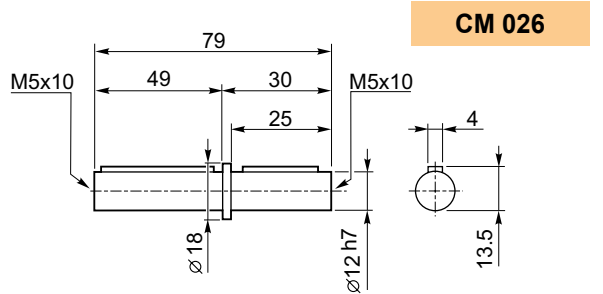

CM 026

Braccio di reazione

Torque arm

	K1	G	KG	KH	R
CM 030	85	14	23	8	15
CM 040	100	14	31	10	18
CM 050	100	14	38	10	18
CM 063	150	14	47.5	10	18
CM 070	200	25	46.5	20	30

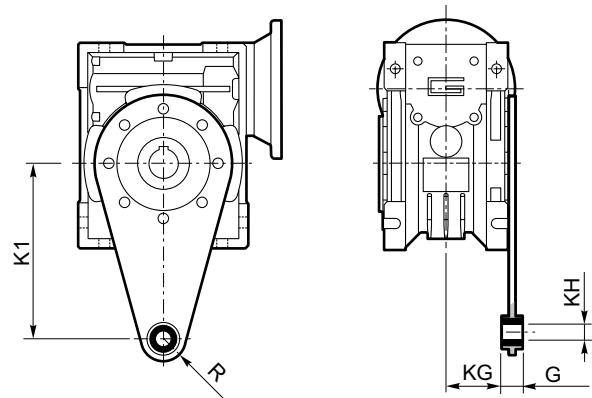

Архангельск (8182)63-90-72	Калининград (4012)72-03-81	Нижний Новгород (831)429-08-12	Смоленск (4812)29-41-54
Астана (7172)727-132	Калуга (4842)92-23-67	Новокузнецк (3843)20-46-81	Сочи (862)225-72-31
Белгород (4722)40-23-64	Кемерово (3842)65-04-62	Новосибирск (383)227-86-73	Ставрополь (8652)20-65-13
Брянск (4832)59-03-52	Киров (8332)68-02-04	Орел (4862)44-53-42	Тверь (4822)63-31-35
Владивосток (423)249-28-31	Краснодар (861)203-40-90	Оренбург (3532)37-68-04	Томск (3822)98-41-53
Волгоград (844)278-03-48	Красноярск (391)204-63-61	Пенза (8412)22-31-16	Тула (4872)74-02-29
Вологда (8172)26-41-59	Курск (4712)77-13-04	Пермь (342)205-81-47	Тюмень (3452)66-21-18
Воронеж (473)204-51-73	Липецк (4742)52-20-81	Ростов-на-Дону (863)308-18-15	Ульяновск (8422)24-23-59
Екатеринбург (343)384-55-89	Магнитогорск (3519)55-03-13	Рязань (4912)46-61-64	Уфа (347)229-48-12
Иваново (4932)77-34-06	Москва (495)268-04-70	Самара (846)206-03-16	Челябинск (351)202-03-61
Ижевск (3412)26-03-58	Мурманск (8152)59-64-93	Санкт-Петербург (812)309-46-40	Череповец (8202)49-02-64
Казань (843)206-01-48	Набережные Челны (8552)20-53-41	Саратов (845)249-38-78	Ярославль (4852)69-52-93

Единый адрес для всех регионов: ton@nt-rt.ru || www.transtecno.nt-rt.ru