

ECMG

ECMG



Ferrite

Цилиндрические мотор-редукторы Руководство по эксплуатации

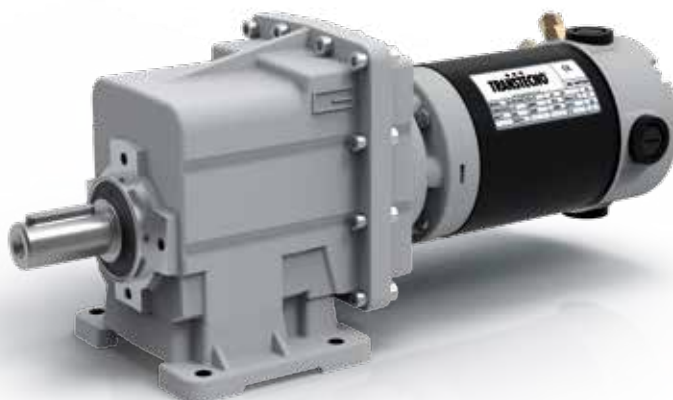

Архангельск (8182)63-90-72
Астана (7172)727-132
Белгород (4722)40-23-64
Брянск (4832)59-03-52
Владивосток (423)249-28-31
Волгоград (844)278-03-48
Вологда (8172)26-41-59
Воронеж (473)204-51-73
Екатеринбург (343)384-55-89
Иваново (4932)77-34-06
Ижевск (3412)26-03-58
Казань (843)206-01-48

Калининград (4012)72-03-81
Калуга (4842)92-23-67
Кемерово (3842)65-04-62
Киров (8332)68-02-04
Краснодар (861)203-40-90
Красноярск (391)204-63-61
Курск (4712)77-13-04
Липецк (4742)52-20-81
Магнитогорск (3519)55-03-13
Москва (495)268-04-70
Мурманск (8152)59-64-93
Набережные Челны (8552)20-53-41

Нижний Новгород (831)429-08-12
Новокузнецк (3843)20-46-81
Новосибирск (383)227-86-73
Орел (4862)44-53-42
Оренбург (3532)37-68-04
Пенза (8412)22-31-16
Пермь (342)205-81-47
Ростов-на-Дону (863)308-18-15
Рязань (4912)46-61-64
Самара (846)206-03-16
Санкт-Петербург (812)309-46-40
Саратов (845)249-38-78

Смоленск (4812)29-41-54
Сочи (862)225-72-31
Ставрополь (8652)20-65-13
Тверь (4822)63-31-35
Томск (3822)98-41-53
Тула (4872)74-02-29
Тюмень (3452)66-21-18
Ульяновск (8422)24-23-59
Уфа (347)229-48-12
Челябинск (351)202-03-61
Череповец (8202)49-02-64
Ярославль (4852)69-52-93

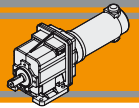

Indice	Index	Pag. Page
Caratteristiche tecniche	<i>Technical features</i>	12
Designazione	<i>Classification</i>	12
Sensi di rotazione	<i>Direction of rotation</i>	13
Lubrificazione	<i>Lubrication</i>	13
Simbologia	<i>Symbols</i>	13
Carichi radiali	<i>Radial loads</i>	14
Motori applicabili	<i>IEC Motor adapters</i>	14
Dati tecnici per servizio S2	<i>Technical data for S2 duty</i>	15
Dimensioni	<i>Dimensions</i>	18

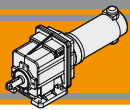

Caratteristiche tecniche

Le caratteristiche principali dei motoriduttori CC ad ingranaggi cilindrici a magneti permanenti in ferrite serie ECMG sono:

- Alimentazione in bassa tensione 12/24 Vcc
- Possibilità di montaggio encoder
- Potenze motore disponibili da 100 a 800W S2
- Magneti in ferrite
- Carcasse dei riduttori in pressofusione di alluminio
- Lubrificazione permanente con olio sintetico
- Ingranaggi sempre rettificati

Technical features

The main features of ECMG ferrite permanent magnets DC helical in-line gearmotors range are:

- Low voltage power supply 12/24 Vdc
- Suitable for encoder assembly
- Motor power ratings available from 100 to 800W S2
- Ferrite magnets
- Die-cast aluminum housing
- Permanent synthetic oil long-life lubrication
- Ground helical gears

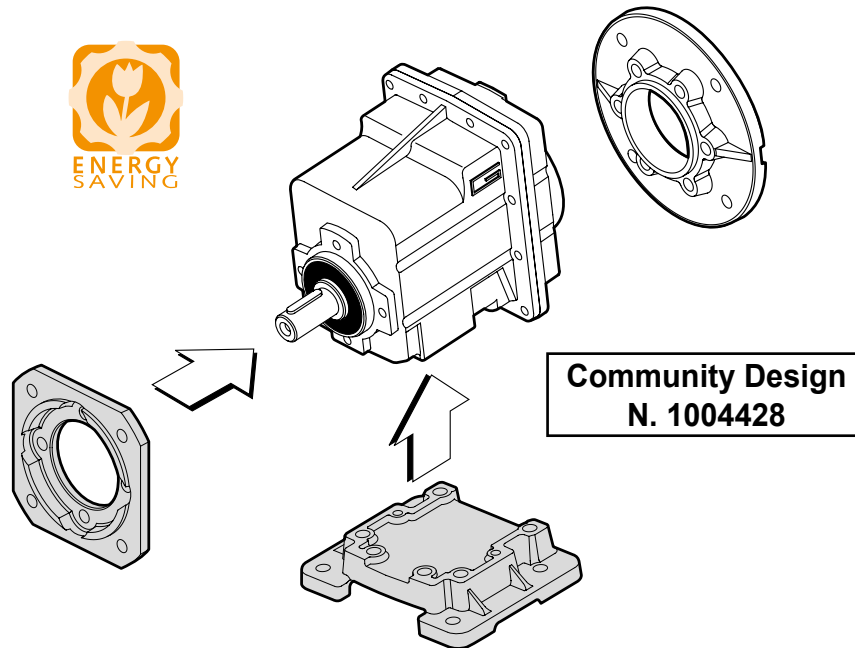

Designazione

Classification

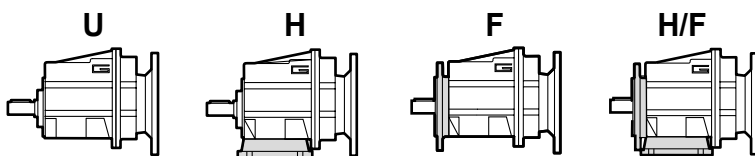

MOTORIDUTTORE / GEARMOTOR

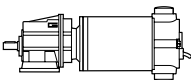
ECMG	100/002						U	8.99	D20	240
Tipo Type	Grandezza Size						Versione Version	Rapporto Ratio	Albero uscita Output shaft	Versione motore Motor version
ECMG 	070/002	100/002	180/002	250/002 250/012 250/013 250/022 250/023 250/033 250/043	350/002 350/012 350/013 350/022 350/023 350/033 350/043	600/002 600/012 600/013 600/022 600/023 600/033 600/043	U... H... F... H.../F...	vedi tabelle see tables	vedi tabelle see tables	120 240 24E

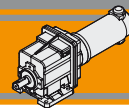

Sensi di rotazione

Direction of rotation

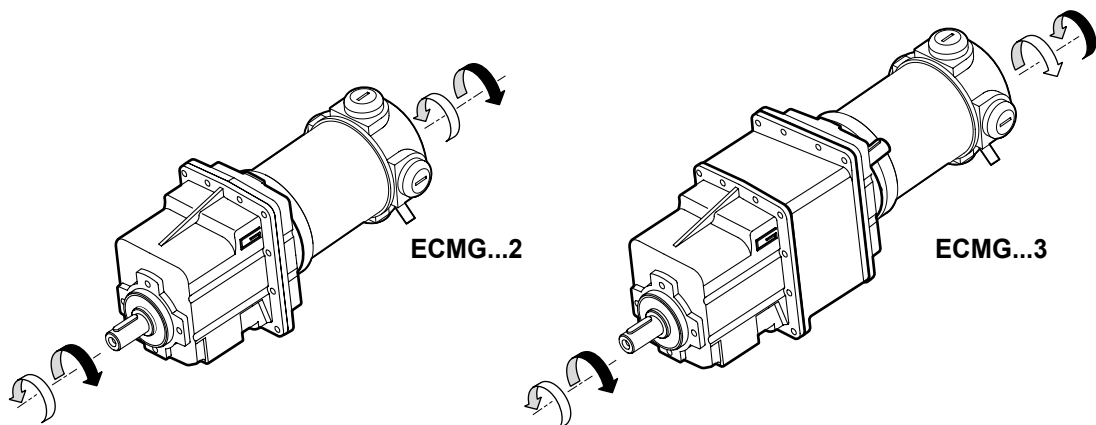

Lubrificazione

Lubrication

Tutti i riduttori sono forniti completi di lubrificante sintetico viscosità 320, pertanto possono essere installati in qualunque posizione di montaggio e non necessitano di manutenzione.

Permanent synthetic oil long-life lubrication (viscosity grade 320) makes it possible to use in all mounting positions; for this reason they can be installed in any assembly position and do not require maintenance.

Simbologia

Symbols

n_1	[min ⁻¹]	Velocità in ingresso / <i>Input speed</i>
n_2	[min ⁻¹]	Velocità in uscita / <i>Output speed</i>
i		Rapporto di riduzione / <i>Ratio</i>
P_1	[kW]	Potenza in entrata / <i>Input power</i>
M_2	[Nm]	Coppia nominale in uscita in funzione di P_1 / <i>Output torque referred to P_1</i>
sf		Fattore di servizio / <i>Service factor</i>
R_2	[N]	Carico radiale ammissibile in uscita / <i>Permitted output radial load</i>
A_2	[N]	Carico assiale ammissibile in uscita / <i>Permitted output axial load</i>

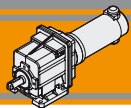

Carichi radiali

Radial loads

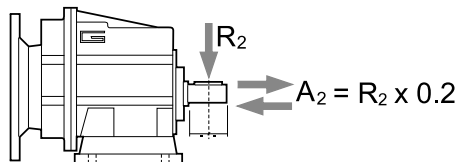

n_2 [min ⁻¹]	R_2 [N]				
	CMG 00	CMG 01	CMG 02	CMG 03	CMG 04
700	416	764	1529	1987	2379
600	437	805	1609	2092	2504
500	465	855	1710	2223	2661
400	501	921	1842	2395	2866
250	586	1077	2154	2801	3353
180	653	1323	2554	3321	3897
150	748	1406	2714	3529	4244
120	806	1631	3467	3801	4572
100	958	1842	3684	4507	5234
80	1032	1984	3969	5042	5991
60	1136	2184	4368	5549	6594
40	1300	2500	5000	6500	8000
10	1300	2500	5000	6500	8000

Quando il carico radiale risultante non è applicato sulla mezzeria dell'albero occorre calcolare quello effettivo con la seguente formula:

When the resulting radial load is not applied on the centre line of the shaft it is necessary to calculate the effective load with the following formula:

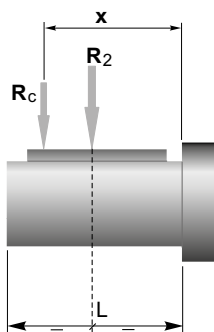

	CMG 00	CMG 01	CMG 02	CMG 03	CMG 04
a	73	104	117	132	150
b	53	84	92	102	115
R_{2MAX}	1300	2500	5000	6500	8000

$$R_c = \frac{R_2 \cdot a}{(b + x)} \leq R_{2MAX}$$

$$R \leq R_c$$

*a, b = valori riportati nella tabella
a, b = values given in the table*

Motori applicabili

IEC Motor adapters

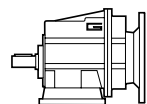
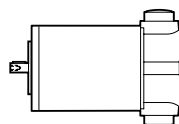

		EC						
		070.12E 070.24E	100.120 100.240 100.24E	180.120 180.240	180.24E	250.120 250.240	350.120 350.240	600.120 600.240
CMG	002	5.03 - 55.10	5.03 - 55.10	5.03 - 55.10	5.03 - 55.10	5.03 - 55.10	5.03 - 55.10	5.03 - 55.10
	012					3.82 - 60.15	3.82 - 60.15	3.82 - 60.15
	013					63.22 - 443.59	63.22 - 443.59	63.22 - 443.59
	022					3.66 - 60.9	3.66 - 60.9	3.66 - 60.9
	023					64.01 - 449.14	64.01 - 449.14	64.01 - 449.14
	033					72.83 - 427.03	72.83 - 427.03	72.83 - 427.03
	043					72.83 - 427.03	72.83 - 427.03	72.83 - 427.03

5.03 - 55.10

Rapporti di riduzione *i*
Ratio *i*

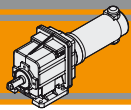

Dati tecnici per servizio S2

Technical data for S2 duty

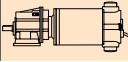
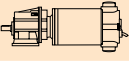
P_1 [W]	n_2 [min ⁻¹]	M_2 [Nm]	sf	i		Versione motore Motor version	P_1 [W]	n_2 [min ⁻¹]	M_2 [Nm]	sf	i		Versione motore Motor version									
350							500															
(3000 min ⁻¹)	47	67	2.3	64.01	250/023	120/240	(3000 min ⁻¹)	168	27	3.4	17.86	350/012	120/240									
	39	80	2.0	76.02					157	29	3.2			19.07								
	33	95	1.6	90.29					151	30	3.1			19.83								
	26	120	1.3	114.46					127	36	2.6			23.56								
	22	142	1.1	135.95					101	45	2.1			29.56								
	17	184	0.8	175.89					85	54	1.7			35.47								
	15	214	0.7	204.69					65	70	1.3			45.89								
	11	223	0.7	264.84					61	75	1.3			49.00								
	10	223	0.7	307.80					56	81.5	1.2			53.33								
	8	223	0.7	398.25					50	92	1.0			60.15								
	7	223	0.7	449.14																		
	41	76	3.1	72.83			250/033	120/240	47	95	1.0			63.22	350/013	120/240						
	31	102	2.3	97.45							40			112			0.8	75.08				
	26	121	1.9	115.74					34	133	0.7	89.17										
	21	147	1.6	140.81					126	36	4.3	23.85	350/022	120/240								
	17	183	1.3	174.26					100	46	3.4	29.93										
	13	236	1.0	225.47					84	55	2.8	35.91										
	11	274	0.9	262.05					65	71	2.2	46.46										
	9	341	0.7	325.79					60	76	2.1	49.61										
	8	334	0.7	378.64					56	83	1.9	54										
	7	334	0.7	427.03					49	93	1.7	60.90										
	41	76	5.1	72.83	250/043	120/240			47	96	1.6	64.01					350/023	120/240				
	31	102	3.8	97.45							39	114							1.4	76.02		
	26	121	3.2	115.74							33	135							1.2	90.29		
	21	147	2.6	140.81					26	171	0.9	114.46										
	17	183	2.1	174.26					22	203	0.8	135.95										
	13	236	1.7	225.47					17	223	0.7	175.89										
	11	274	1.4	262.05					41	109	2.1	72.83	350/033	120/240								
	9	341	1.1	325.79					31	146	1.6	97.45										
	8	397	1.0	378.64					26	173	1.4	115.74										
	7	447	0.9	427.03					21	211	1.1	140.81										
									17	261	0.9	174.26										
									13	334	0.7	225.47										
									11	334	0.7	262.05										
							41	109	3.6	72.83	350/043	120/240										
							31	146	2.7	97.45												
							26	173	2.3	115.74												
							21	211	1.9	140.81												
							17	261	1.5	174.26												
							13	337	1.2	225.47												
							11	392	1.0	262.05												
							9	487	0.8	325.79												
							8	557	0.7	378.64												
							7	557	0.7	427.03												
500																						
(3000 min ⁻¹)	596	7.7	4.0	5.03	350/002	120/240																
	492	9.3	3.3	6.10																		
	401	11	2.7	7.49																		
	334	14	2.8	8.99																		
	295	16	2.5	10.16																		
	249	18	2.1	12.07																		
	224	20	2.7	13.40																		
	198	23	2.4	15.14																		
	165	28	2.0	18.17																		
	139	33	1.7	21.58																		
	128	36	1.5	23.51																		
	120	38	1.4	25.1																		
	111	41	1.3	27.08																		
	92	50	1.1	32.49																		
	71	64	0.9	42.04																		
	67	69	0.8	44.89																		
	61	75	0.7	48.86																		
	785	6	8.1	3.82			350/012	120/240														
	648	7	6.6	4.63																		
	527	9	5.4	5.69																		
	389	12	5.3	7.72																		
	327	14	4.4	9.17																		
	306	15	4.1	9.81																		
	261	18	4.4	11.5																		
	252	18	4.3	11.9																		
	217	21	4.5	13.80																		
	205	22	4.2	14.62																		

N.B.
Verificare sempre che la coppia M2 utilizzata non ecceda il valore indicato nelle caselle in grigio
N.B.
Please check that the output torque M2 does not exceed the value in the grey areas

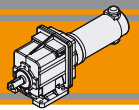

Dati tecnici per servizio S2

Technical data for S2 duty

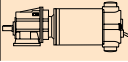
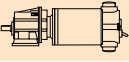
P ₁ [W]	n ₂ [min ⁻¹]	M ₂ [Nm]	sf	i		Versione motore Motor version	P ₁ [W]	n ₂ [min ⁻¹]	M ₂ [Nm]	sf	i		Versione motore Motor version				
800							800										
(3000 min ⁻¹)	596	12	2.5	5.03	600/002	120/240	(3000 min ⁻¹)	302	24	3.9	9.93	600/022	120/240				
	492	15	2.1	6.10				272	27	5.8	11.01						
	401	18	1.7	7.49				249	29	5.3	12.05						
	334	22	1.8	8.99				227	32	4.8	13.21						
	295	25	1.6	10.16				203	36	4.3	14.81						
	249	30	1.3	12.07				175	42	3.0	17.1						
	224	33	1.7	13.40				164	45	2.8	18.26						
	198	37	1.5	15.14				149	49	3.2	20.08						
	165	44	1.2	18.17				126	58	2.7	23.85						
	139	53	1.0	21.58				100	73	2.1	29.93						
	128	57	1.0	23.51				84	88	1.8	35.91						
	120	61	0.9	25.10				65	114	1.4	46.46						
	111	66	0.8	27.08				60	121	1.3	49.61						
	92	79	0.7	32.49				56	132	1.2	54						
	71	79	0.7	42.04				49	149	1.0	60.90						
	67	79	0.7	44.89													
	785	9	5.0	3.82			600/012	120/240	47	153	1.0			64.01	600/023	120/240	
	648	11	4.2	4.63		39			182	0.9	76.02						
	527	14	3.4	5.69		33			216	0.7	90.29						
	389	19	3.3	7.72		26			223	0.7	114.46						
	327	22	2.8	9.17		22			223	0.7	135.95						
	306	24	2.6	9.81		41			174	1.3	72.83	600/033	120/240				
	261	28	2.8	11.5		31			233	1.0	97.45						
	252	29	2.7	11.9		26			277	0.8	115.74						
	217	34	2.8	13.8		21			334	0.7	140.81						
	205	36	2.6	14.62		17			334	0.7	174.26						
	168	44	2.2	17.86		13			334	0.7	225.47						
	157	47	2.0	19.07													
	151	48	1.9	19.83		41			174	2.2	72.83			600/043			120/240
	127	58	1.6	23.56		31			233	1.7	97.45						
	101	72	1.3	29.56		26			277	1.4	115.74						
	85	87	1.1	35.47		21			337	1.2	140.81						
	65	112	0.8	45.89		17			417	0.9	174.26						
	61	120	0.8	49		13	540	0.7	225.47								
	56	130	0.7	53.33		11	557	0.7	262.05								
						9	557	0.7	325.79								
	47	134	0.7	63.22	600/013	120/240											
	40	134	0.7	75.08													

ECMG

N.B.
Verificare sempre che la coppia M2 utilizzata non ecceda il valore indicato nelle caselle in grigio
N.B.
Please check that the output torque M2 does not exceed the value in the grey areas



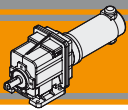

Dimensioni

Dimensions

ECMG..U

ECMG070/002 U

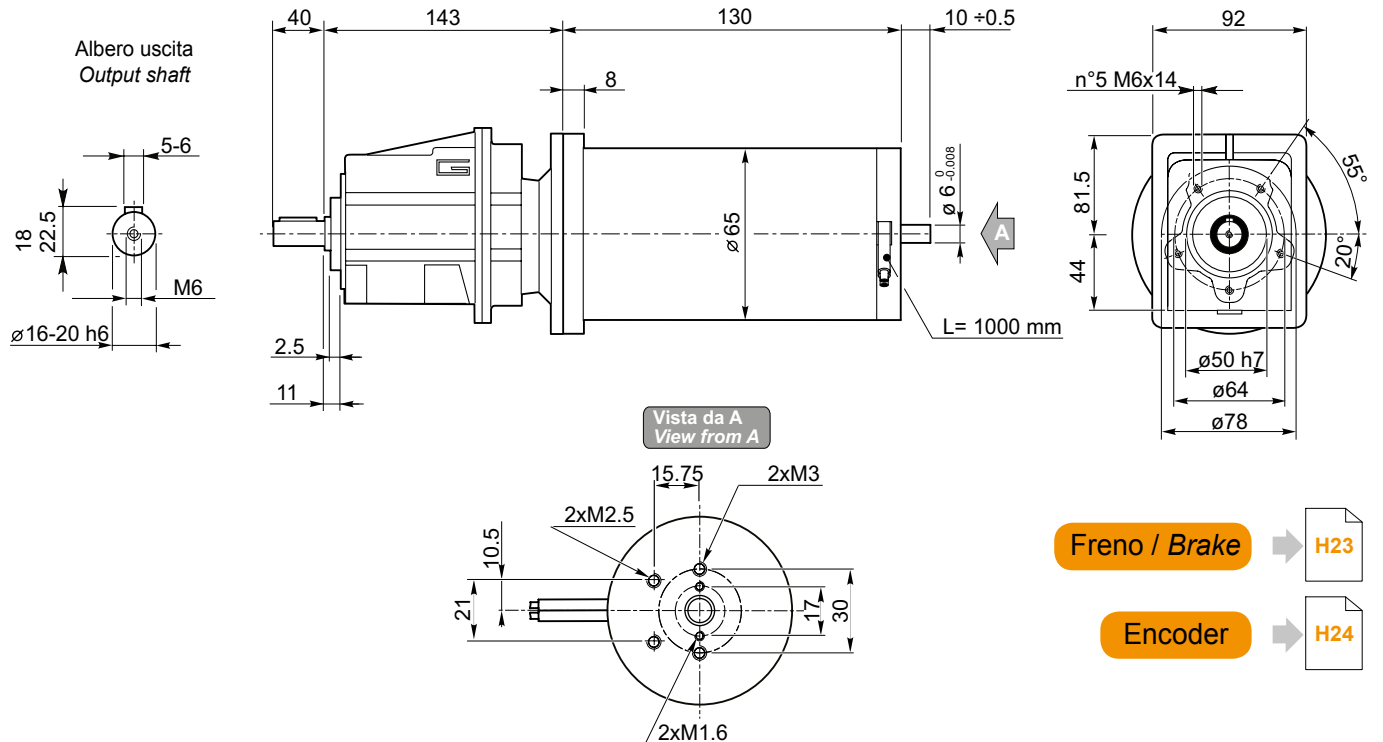

ECMG100/002 U

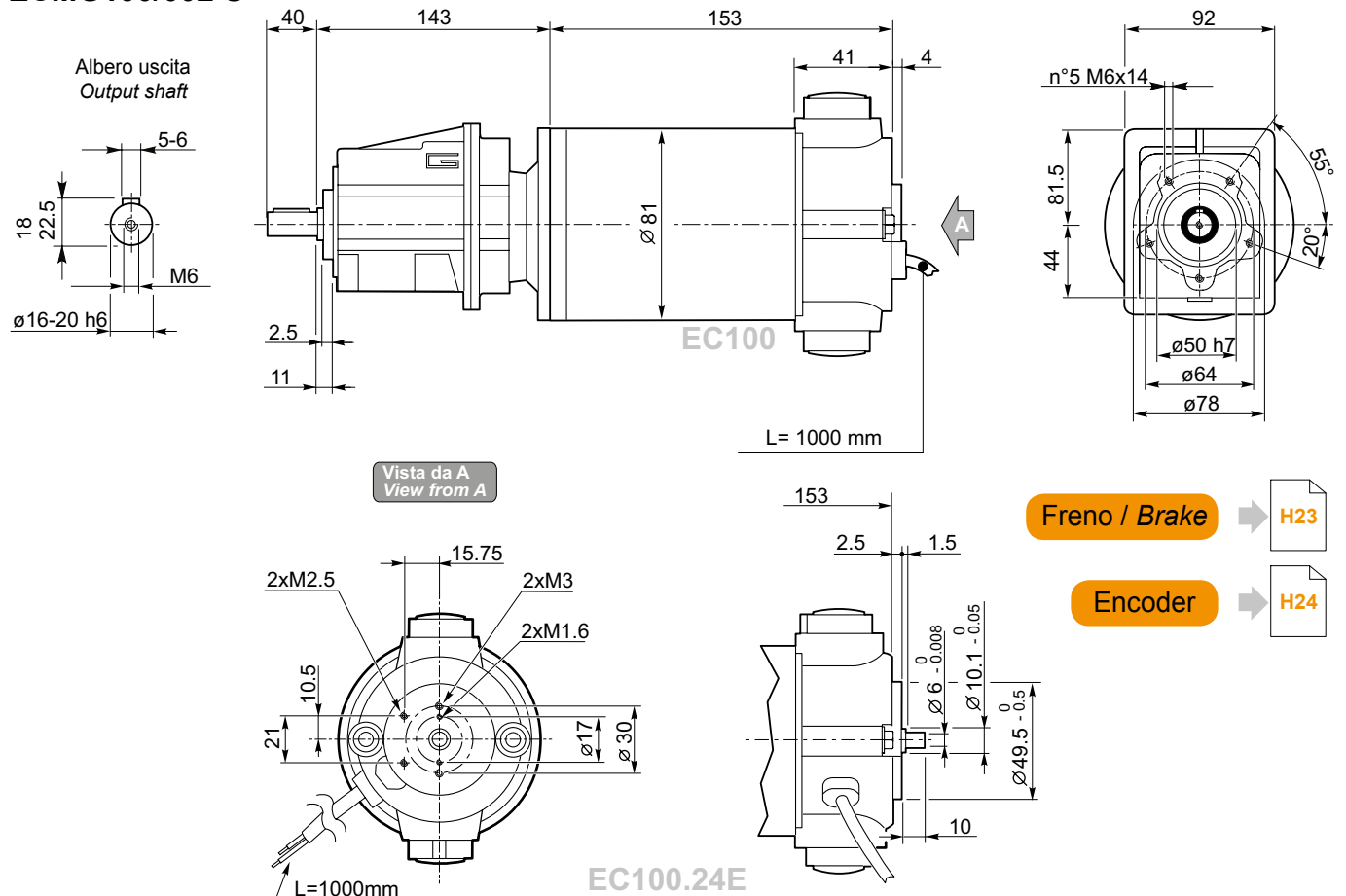

ECMG...H → I18

ECMG...F → I19

ECMG...H/F → I20

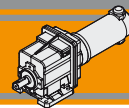

Dimensioni

Dimensions

ECMG..U

ECMG180/002 U

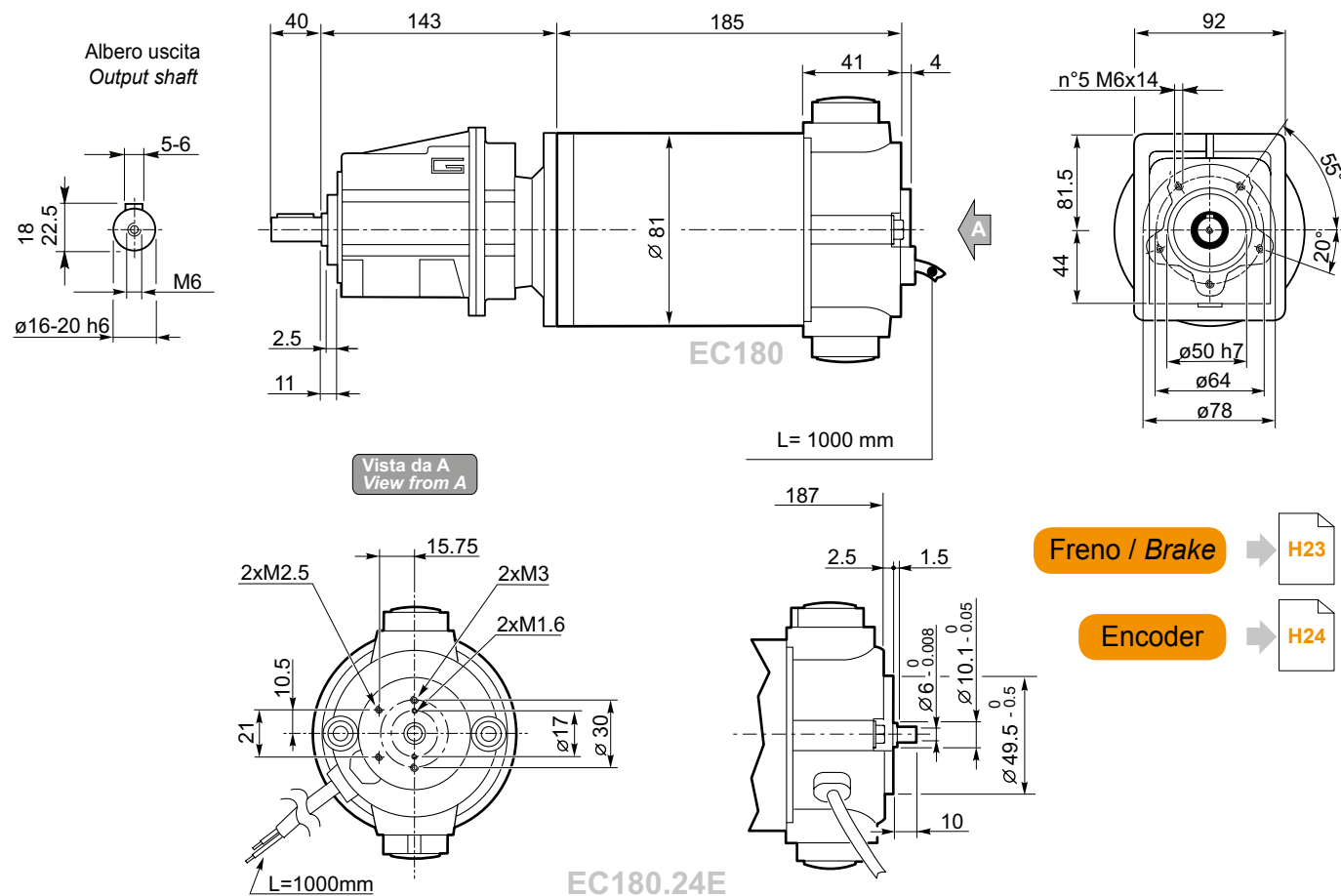

ECMG

ECMG...H → I18

ECMG...F → I19

ECMG...H/F → I20

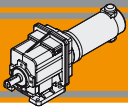

Dimensioni

Dimensions

ECMG..U

ECMG250/002 U

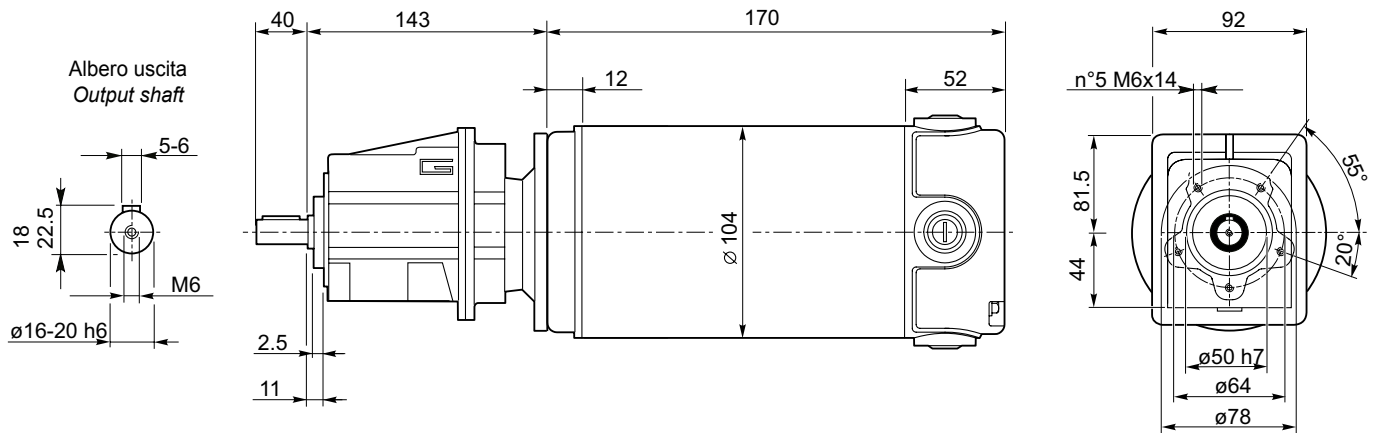

ECMG250/012 U

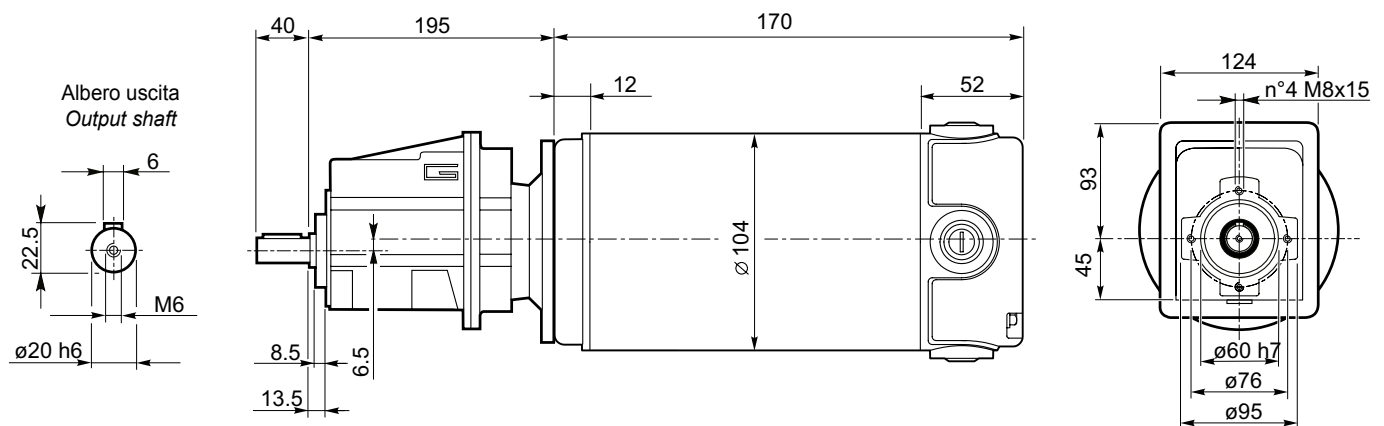

ECMG250/013 U

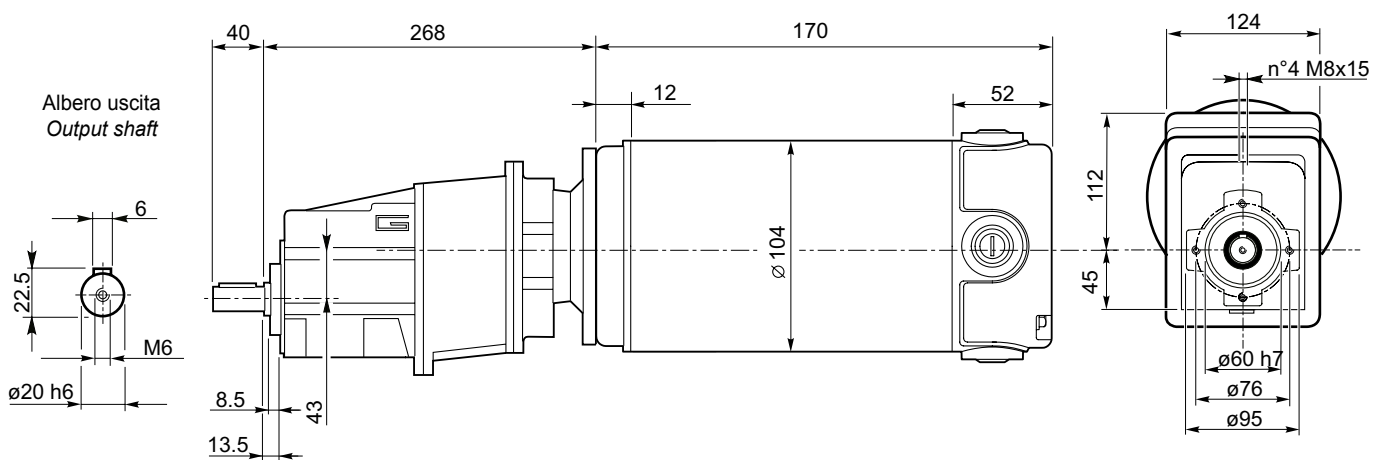

ECMG...H → **I18**

ECMG...F → **I19**

ECMG...H/F → **I20**

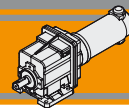

Dimensioni

Dimensions

ECMG..U

ECMG250/022 U

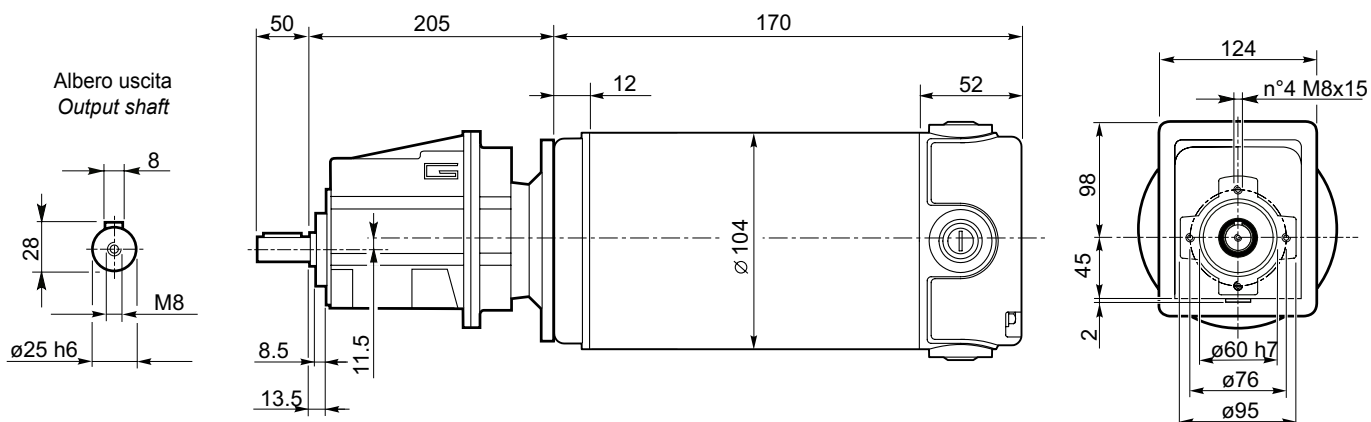

ECMG250/023 U

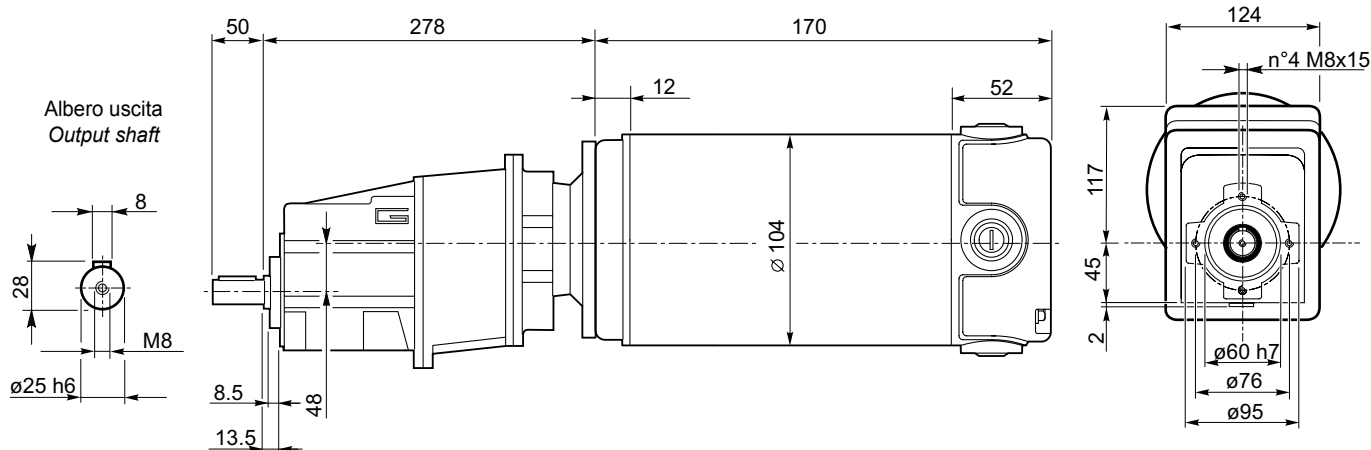

ECMG250/033 U

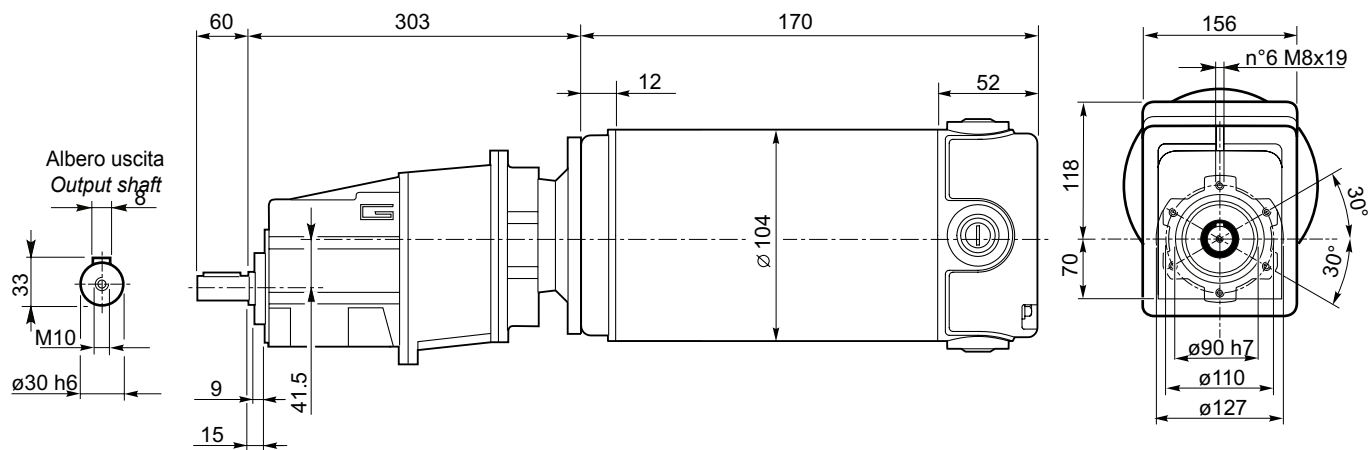

ECMG

ECMG...H → **I18**

ECMG...F → **I19**

ECMG...H/F → **I20**

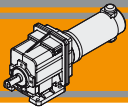

Dimensioni

Dimensions

ECMG..U

ECMG250/043 U

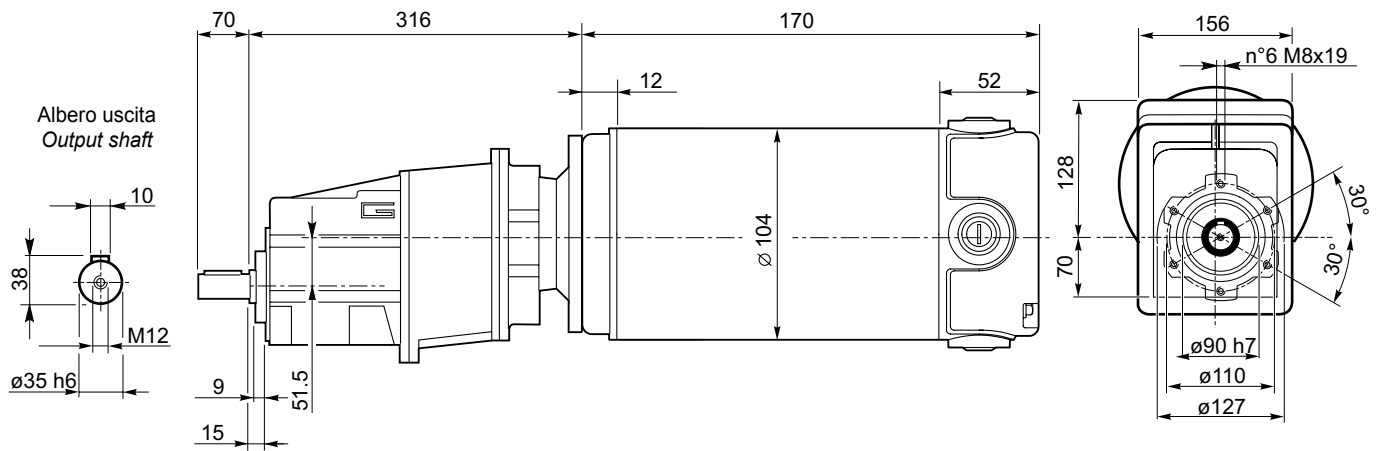

ECMG...H → [I18](#)

ECMG...F → [I19](#)

ECMG...H/F → [I20](#)

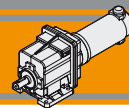

Dimensioni

Dimensions

ECMG..U

ECMG350/002 U

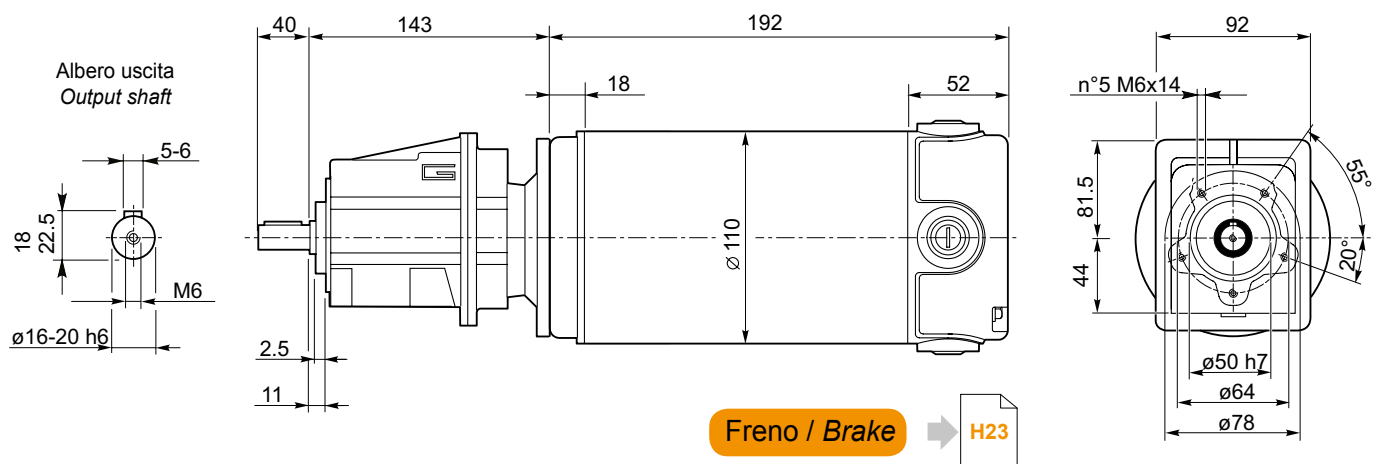

ECMG350/012 U

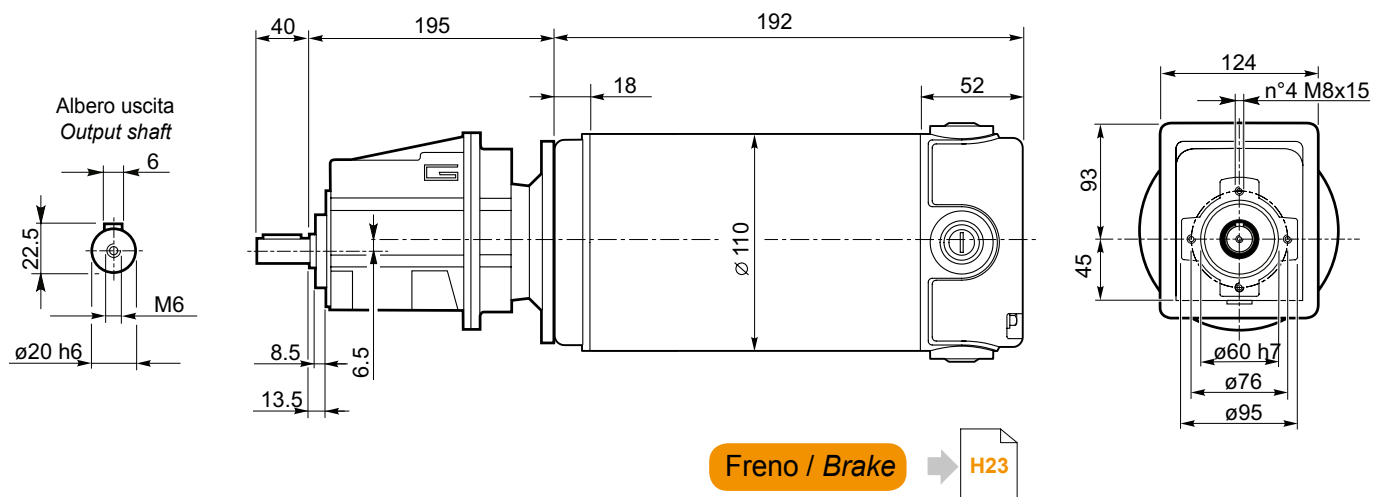

ECMG350/013 U

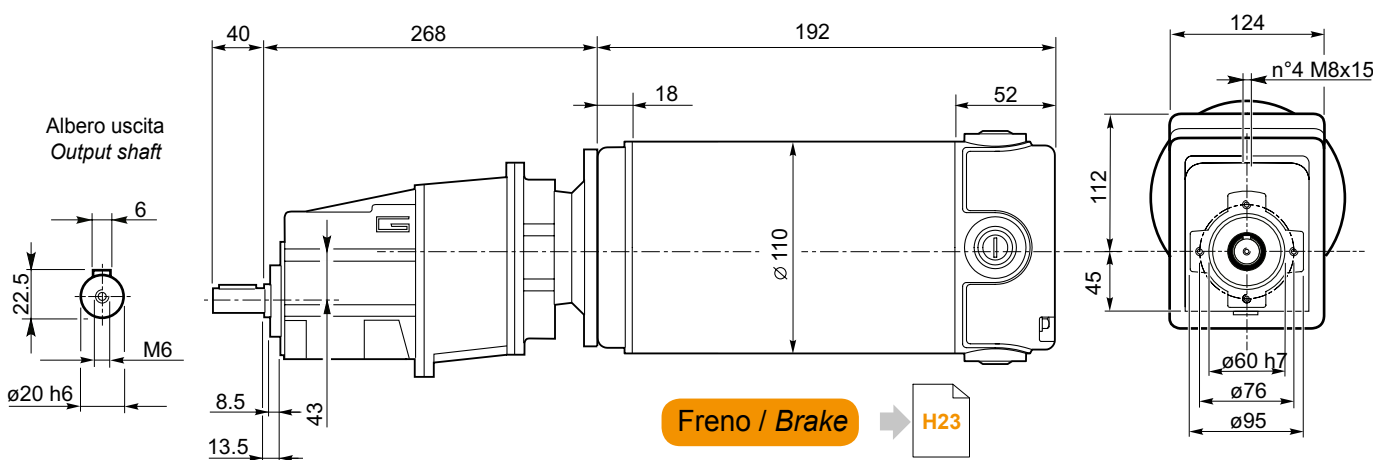

ECMG

ECMG...H → I18

ECMG...F → I19

ECMG...H/F → I20

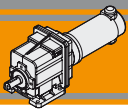

Dimensioni

Dimensions

ECMG..U

ECMG350/022 U

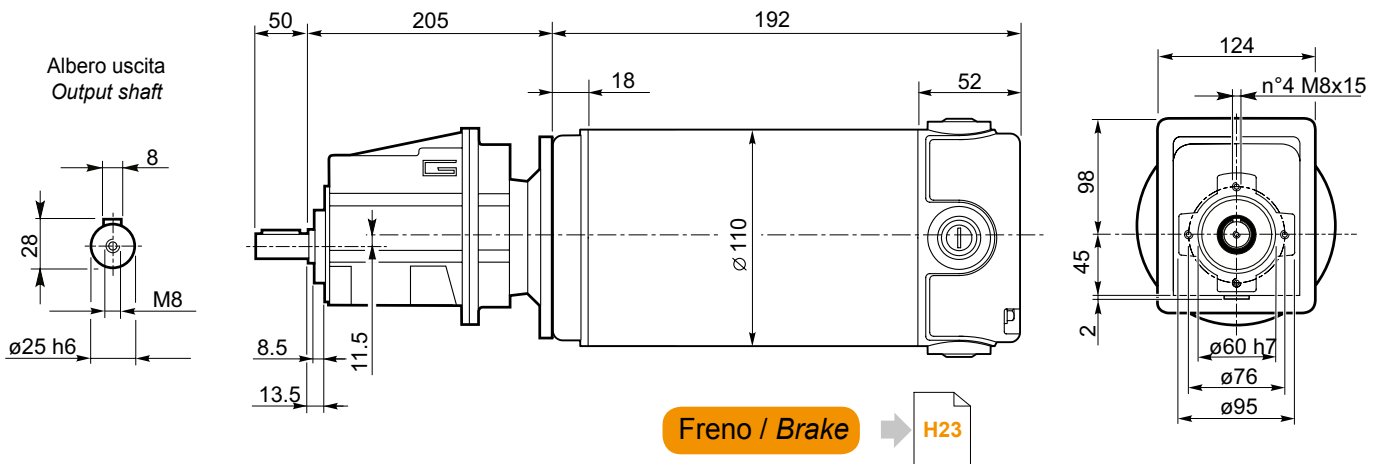

ECMG350/023 U

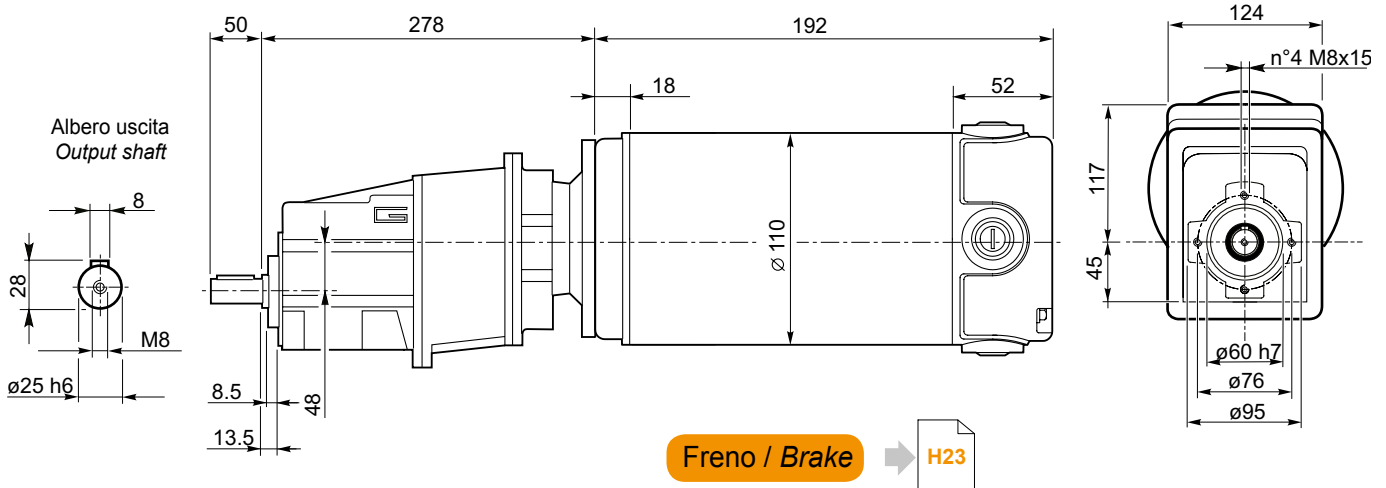

ECMG350/033 U

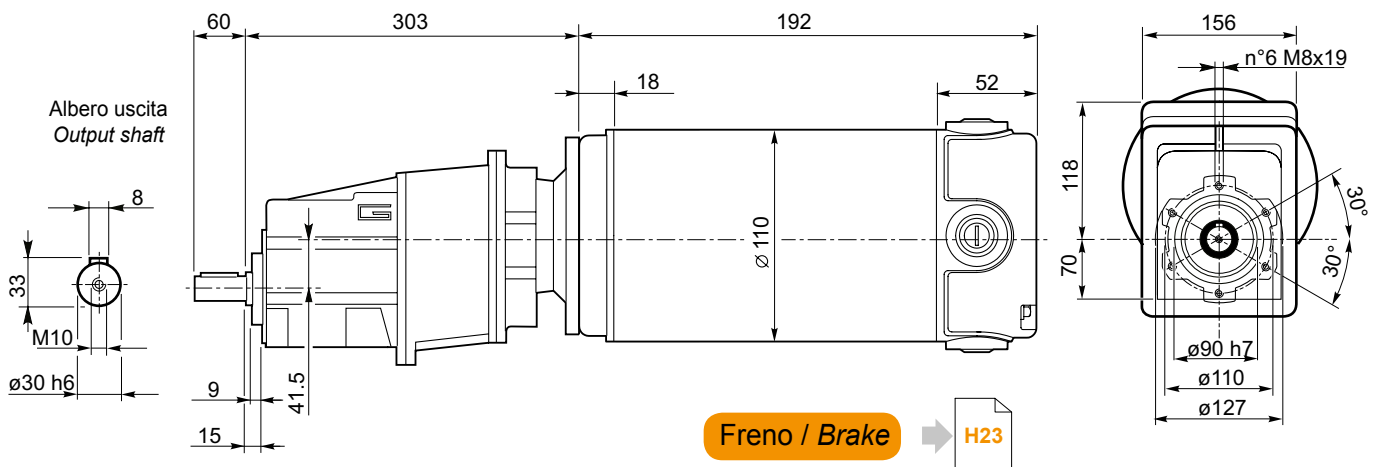

ECMG...H → I18

ECMG...F → I19

ECMG...H/F → I20

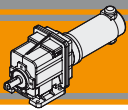

Dimensioni

Dimensions

ECMG..U

ECMG600/012 U

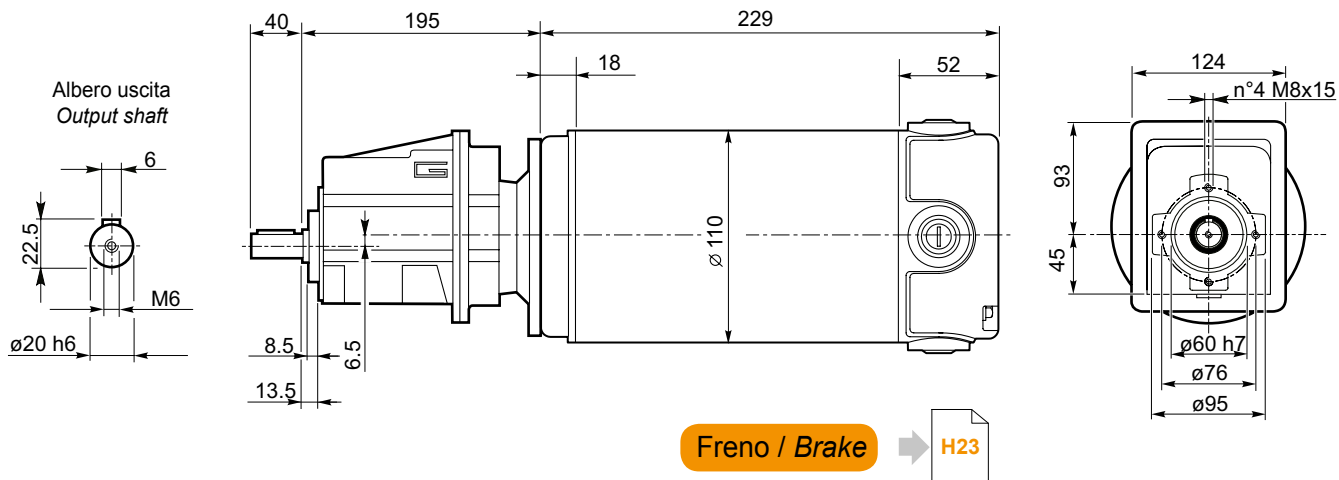

ECMG600/013 U

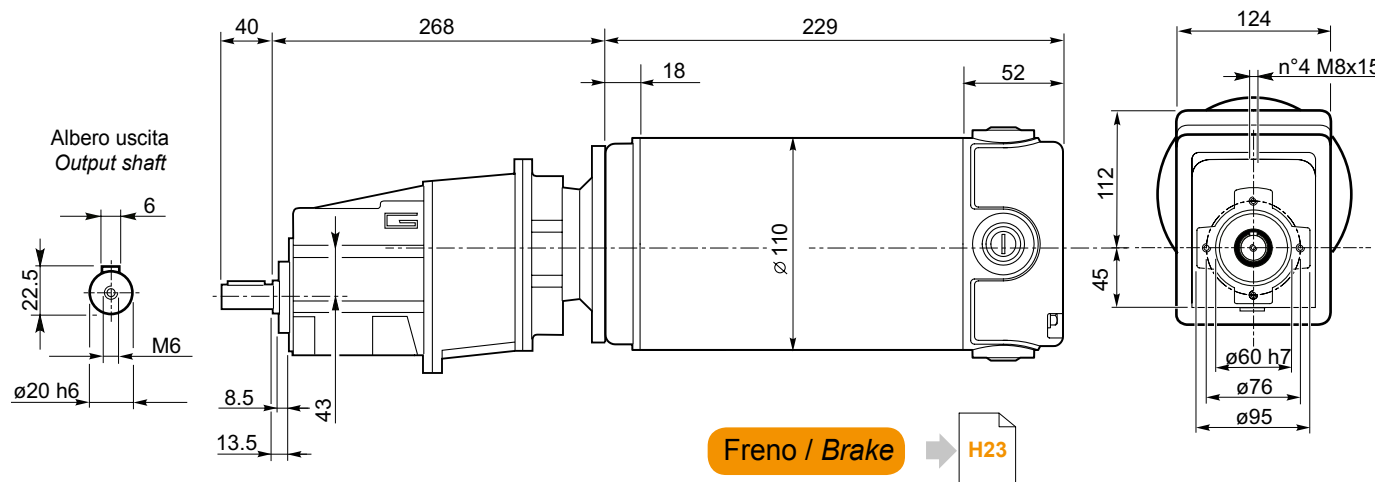

ECMG600/022 U

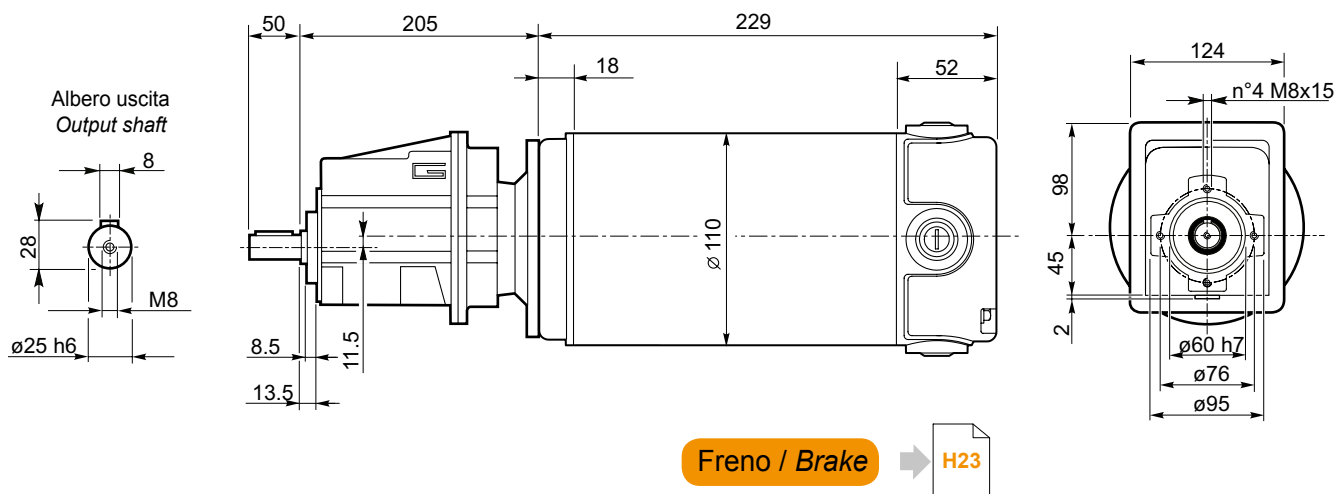

ECMG...H → I18

ECMG...F → I19

ECMG...H/F → I20

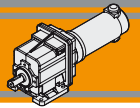

Dimensioni

Dimensions

ECMG..U

ECMG600/023 U

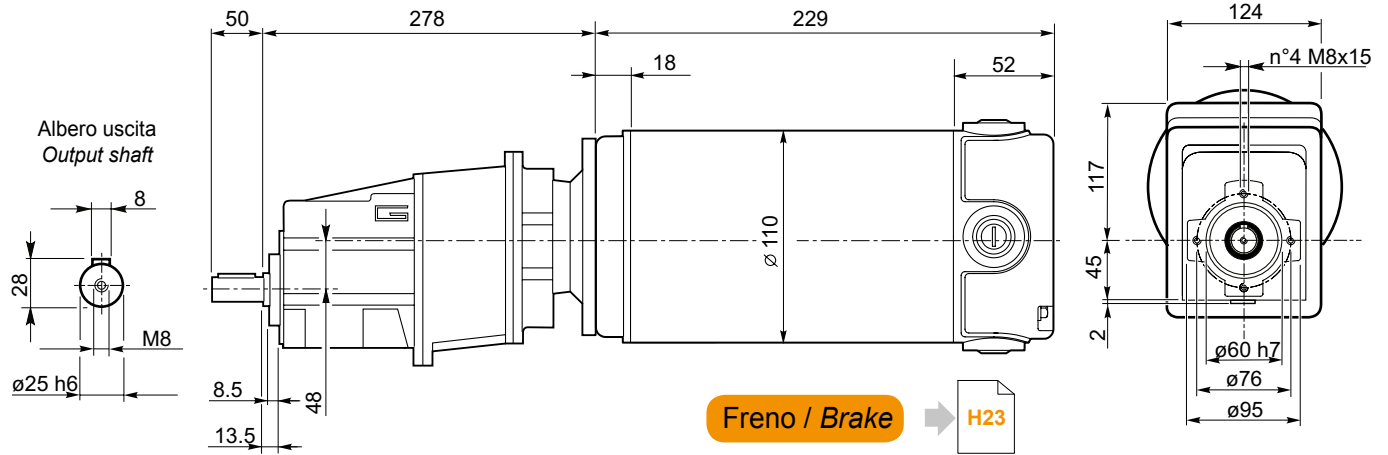

ECMG600/033 U

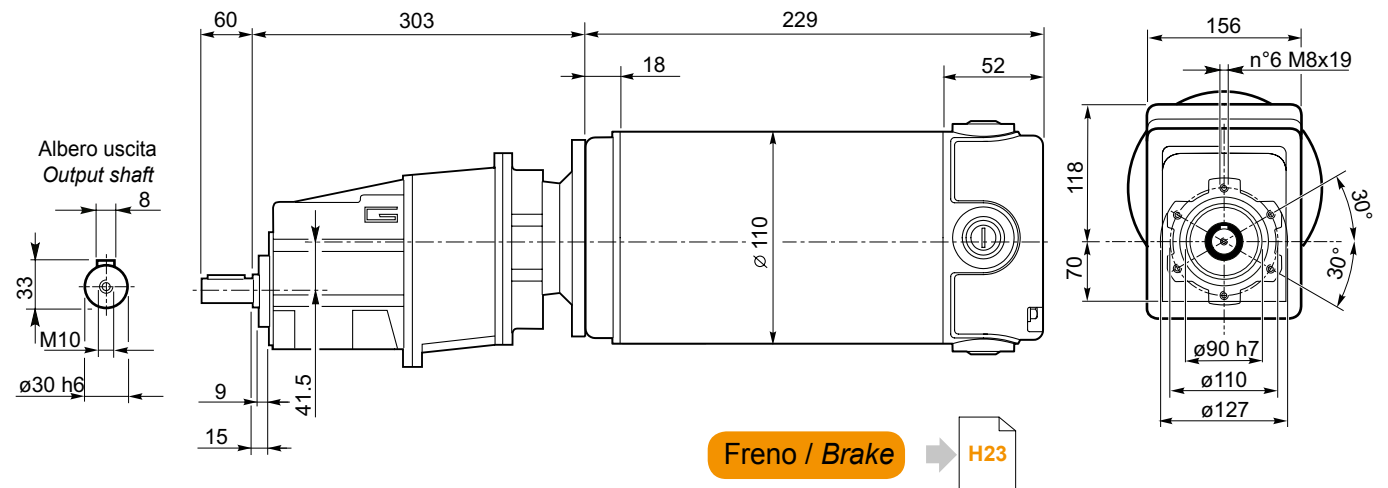

ECMG600/043 U

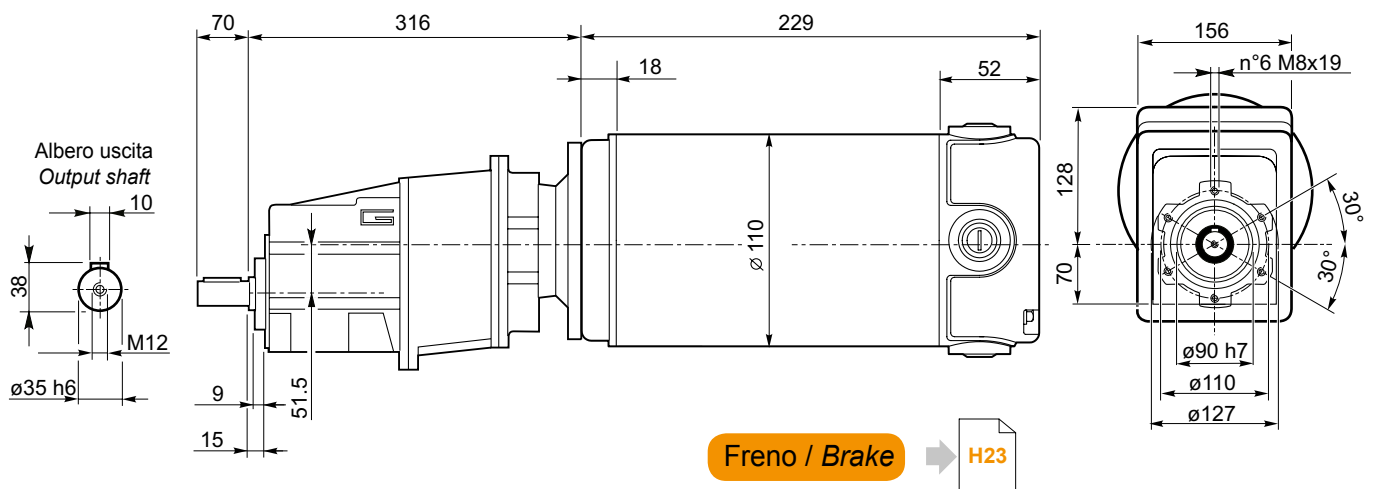

ECMG

ECMG...H → I18

ECMG...F → I19

ECMG...H/F → I20

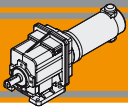

Dimensioni

Dimensions

ECMG..H

ECMG..2 H..

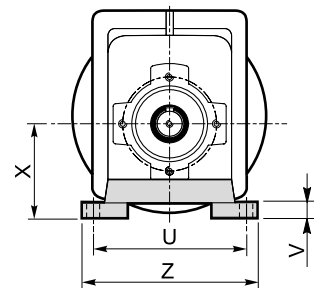
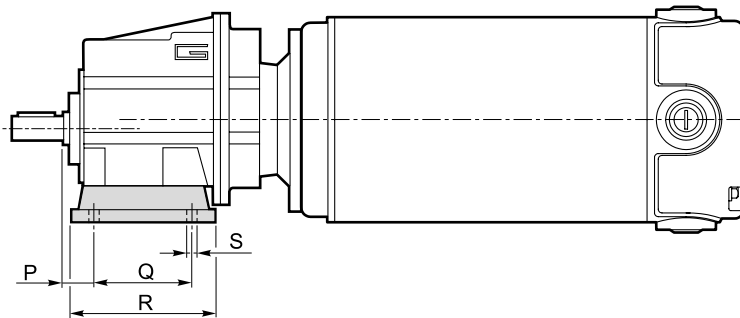

ECMG..3 H..

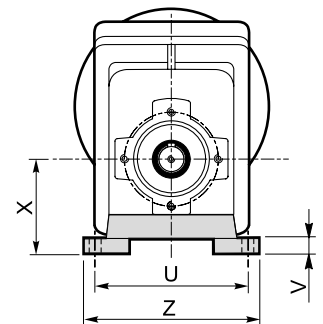
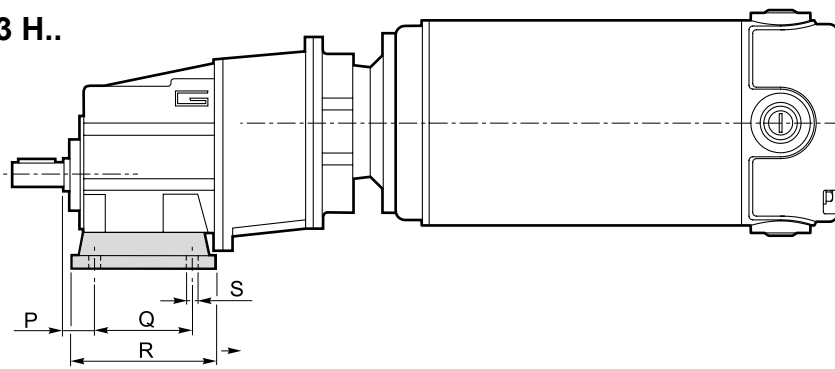

Versione H / H Version

CMG	P	Q	R	S	U	V	X	Z	Piede / Foot	
									Tipo / Type	Peso / Weight [kg]
002	18	60	80	9	100	10	60	120	H60	0.2
	18	80	104	9	110 - 120	10	75	145	H75	0.3
	18	50 - 87	110	9	110	10	85	135	H85	0.4
012 013	20	85	108	9	115	12	65	139	H65	0.7
	18	80	118	9	110	12	75	140	H75	1.0
	25	85	120	9	120	12	80	140	H80	1.1
	18	50 - 87	118	9	110	12	85	130	H85	1.2
	25	130	154	9	110	12	90	135	H90	1.5
	18	60 - 107.5	135	11	130	12	100	155	H100	1.7
022 023	20	85	108	9	115	12	65	139	H65	0.7
	18	80	118	9	110	12	75	140	H75	1.0
	25	85	120	9	120	12	80	140	H80	1.1
	18	50 - 87	118	9	110	12	85	130	H85	1.2
	25	130	154	9	110	12	90	135	H90	1.5
	18	60 - 107.5	135	11	130	12	100	155	H100	1.7
033	30	105	136	14	160	14	95	194	H95	1.5
	30	100	150	11	150	14	110	185	H110	1.9
	18	70			160					
	30	165	195	14	135	14	115	170	H115	2.2
	35	110	160	14	170	14	120	210	H120	2.6
043	30	105	136	14	160	14	95	194	H95	1.5
	30	100	150	11	150	14	110	185	H110	1.9
	18	70			160					
	30	165	195	14	135	14	115	170	H115	2.2
	35	110	160	14	170	14	120	210	H120	2.6

Preferenziale / Preferred

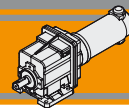

Dimensioni

Dimensions

ECMG..F

ECMG..2 F..

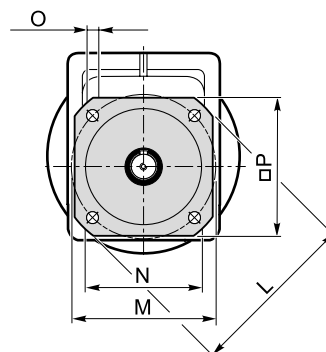
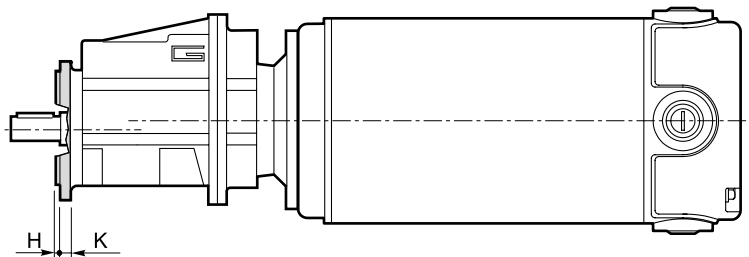

ECMG..3 F..

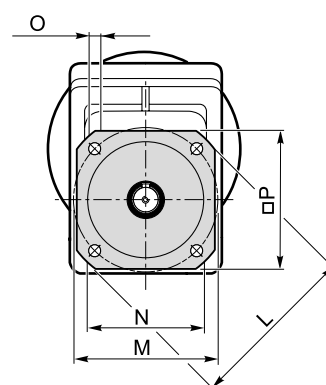
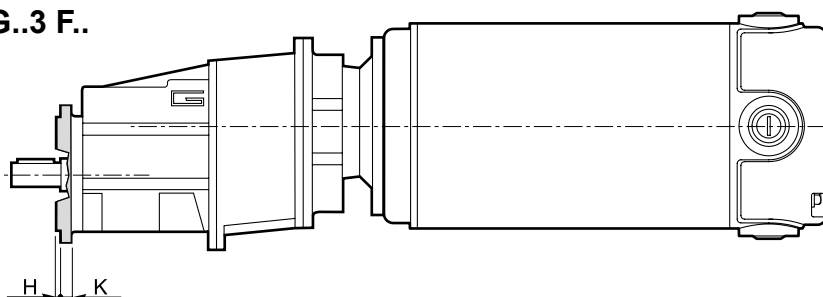

ECMG

Versione F / F Version									
CMG	H	K	L	M	N f7	O	P	Flangia / Flange	
								Tipo / Type	Peso / Weight [kg]
002	3.5	7	105	85	70	6.5	90	F105	0.1
	3.5	8	120	100	80	7	100	F120	0.2
	3.5	8	140	115	95	9	115	F140	0.2
012 013	3	9	120	100	80	9	106	F120	0.5
	3.5	9	140	115	95	9	115	F140	0.8
	3.5	9	160	130	110	9	126	F160	1.1
	3.5	11	200	165	130	11	165	F200	1.8
022 023	3	9	120	100	80	9	106	F120	0.5
	3.5	9	140	115	95	9	115	F140	0.8
	3.5	9	160	130	110	9	126	F160	1.1
	3.5	11	200	165	130	11	165	F200	1.8
033	3.5	11	160	130	110	9	140	F160	1.0
	3.5	11	200	165	130	11	165	F200	1.8
	4	13	250	215	180	14	215	F250	2.9
043	3.5	11	160	130	110	9	140	F160	1.0
	3.5	11	200	165	130	11	165	F200	1.8
	4	13	250	215	180	14	215	F250	2.9

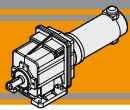

Dimensioni

Dimensions

Versione H / H Version											Combinazioni possibili H/F Possible combinations H/F						
CMG	P	Q	R	S	U	V	X	Z	Piede / Foot		F105	F120	F140	F160	F200	F250	F300
									Tipo / Type	Peso / Weight [kg]							
002	18	60	80	9	100	10	60	120	H60	0.2	•	•	•				
	18	80	104	9	110 - 120	10	75	145	H75	0.3	•	•	•				
	18	50 - 87	110	9	110	10	85	135	H85	0.4	•	•	•				
012 013	20	85	108	9	115	12	65	139	H65	0.7		•	•				
	18	80	118	9	110	12	75	140	H75	1.0		•	•	•			
	25	85	120	9	120	12	80	140	H80	1.1		•	•	•			
	18	50 - 87	118	9	110	12	85	130	H85	1.2		•	•	•			
	25	130	154	9	110	12	90	135	H90	1.5		•	•	•	•		
	18	60 - 107.5	135	11	130	12	100	155	H100	1.7		•	•	•	•		
022 023	20	85	108	9	115	12	65	139	H65	0.7		•	•				
	18	80	118	9	110	12	75	140	H75	1.0		•	•	•			
	25	85	120	9	120	12	80	140	H80	1.1		•	•	•			
	18	50 - 87	118	9	110	12	85	130	H85	1.2		•	•	•			
	25	130	154	9	110	12	90	135	H90	1.5		•	•	•	•		
	18	60 - 107.5	135	11	130	12	100	155	H100	1.7		•	•	•	•		
033	30	105	136	14	160	14	95	194	H95	1.5				•	•		
	30	100	150	11	150	14	110	185	H110	1.9				•	•		
	18	70			160												
	30	165	195	14	135	14	115	170	H115	2.2				•	•	•	
	35	110	160	14	170	14	120	210	H120	2.6				•	•	•	
043	30	105	136	14	160	14	95	194	H95	1.5				•	•		
	30	100	150	11	150	14	110	185	H110	1.9				•	•		
	18	70			160												
	30	165	195	14	135	14	115	170	H115	2.2				•	•	•	
	35	110	160	14	170	14	120	210	H120	2.6				•	•	•	

Preferenziale / Preferred

• Combinazioni possibili H/F / Possible combinations H/F

Versione F / F Version									
CMG	H	K	L	M	N f7	O	P	Flangia / Flange	
								Tipo / Type	Peso / Weight [kg]
002	3.5	7	105	85	70	6.5	90	F105	0.1
	3.5	8	120	100	80	7	100	F120	0.2
	3.5	8	140	115	95	9	115	F140	0.2
012 013	3	9	120	100	80	9	106	F120	0.5
	3.5	9	140	115	95	9	115	F140	0.8
	3.5	9	160	130	110	9	126	F160	1.1
	3.5	11	200	165	130	11	165	F200	1.8
022 023	3	9	120	100	80	9	106	F120	0.5
	3.5	9	140	115	95	9	115	F140	0.8
	3.5	9	160	130	110	9	126	F160	1.1
	3.5	11	200	165	130	11	165	F200	1.8
033	3.5	11	160	130	110	9	140	F160	1.0
	3.5	11	200	165	130	11	165	F200	1.8
	4	13	250	215	150	14	215	F250	2.9
043	3.5	11	160	130	110	9	140	F160	1.0
	3.5	11	200	165	130	11	165	F200	1.8
	4	13	250	215	150	14	215	F250	2.9

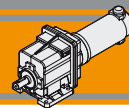

Dimensioni

Dimensions

ECMG..H../F..

ECMG..2 H../F..

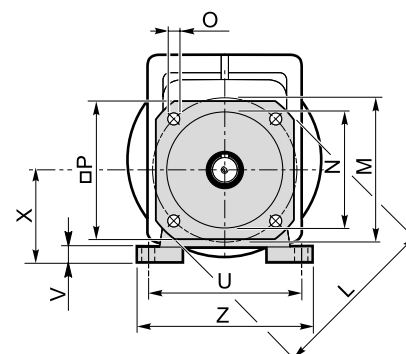
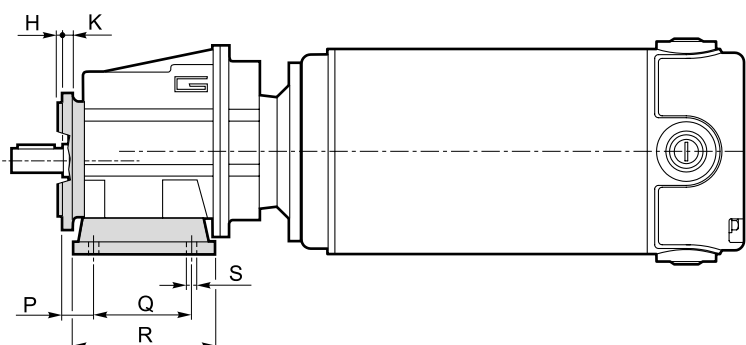

ECMG..3 H../F..

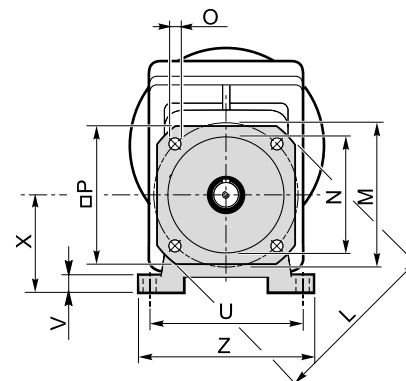
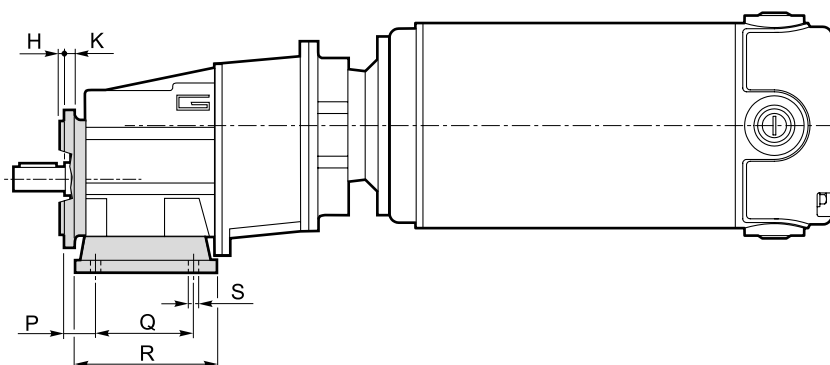

ECMG

Архангельск (8182)63-90-72
Астана (7172)727-132
Белгород (4722)40-23-64
Брянск (4832)59-03-52
Владивосток (423)249-28-31
Волгоград (844)278-03-48
Вологда (8172)26-41-59
Воронеж (473)204-51-73
Екатеринбург (343)384-55-89
Иваново (4932)77-34-06
Ижевск (3412)26-03-58
Казань (843)206-01-48

Калининград (4012)72-03-81
Калуга (4842)92-23-67
Кемерово (3842)65-04-62
Киров (8332)68-02-04
Краснодар (861)203-40-90
Красноярск (391)204-63-61
Курск (4712)77-13-04
Липецк (4742)52-20-81
Магнитогорск (3519)55-03-13
Москва (495)268-04-70
Мурманск (8152)59-64-93
Набережные Челны (8552)20-53-41

Нижний Новгород (831)429-08-12
Новокузнецк (3843)20-46-81
Новосибирск (383)227-86-73
Орел (4862)44-53-42
Оренбург (3532)37-68-04
Пенза (8412)22-31-16
Пермь (342)205-81-47
Ростов-на-Дону (863)308-18-15
Рязань (4912)46-61-64
Самара (846)206-03-16
Санкт-Петербург (812)309-46-40
Саратов (845)249-38-78

Смоленск (4812)29-41-54
Сочи (862)225-72-31
Ставрополь (8652)20-65-13
Тверь (4822)63-31-35
Томск (3822)98-41-53
Тула (4872)74-02-29
Тюмень (3452)66-21-18
Ульяновск (8422)24-23-59
Уфа (347)229-48-12
Челябинск (351)202-03-61
Череповец (8202)49-02-64
Ярославль (4852)69-52-93

Единый адрес для всех регионов: ton@nt-rt.ru || www.transtecno.nt-rt.ru